

Hoop FEVER™



OWNERS AND SERVICE MANUAL INNOVATIVE CONCEPTS IN ENTERTAINMENT INC.

10123 MAIN STREET, CLARENCE, NY 14031

SERVICE: 1-716-759-0360

FAX: 1-716-759-0884

E-MAIL: service@icegame.com

WEBSITE: www.icegame.com

TABLE OF CONTENTS

| | |
|------------------------------------|--------------|
| INTRODUCTION..... | PAGE 3 |
| • GAME FEATURES | |
| • GAME PLAY | |
| ASSEMBLY..... | PAGE 4 - 6 |
| • SAFETY PRECAUTIONS | |
| • GAME SET-UP | |
| CUSTOMIZING YOUR GAME..... | PAGE 7 - 9 |
| • ENTERING SET-UP MODE | |
| • CHANGING GAME SETTINGS | |
| • PROGRAMMING MODES | |
| QUICK TROUBLESHOOTING..... | PAGE 10 |
| MAINTENANCE & TROUBLESHOOTING..... | PAGE 11 - 14 |
| • OPERATIONAL BACKGROUND | |
| • MECHANICAL REPAIR | |
| • MECHANICAL MAINTENANCE | |
| • ELECTRONIC & ELECTRICAL REPAIR | |
| OPTIONAL ACCESSORIES..... | PAGE 15 |
| • TICKET DISPENSER | |
| • DOLLAR BILL VALIDATOR | |
| ABOUT LINKING..... | PAGE 16 |
| PARTS LISTING..... | PAGE 17 |
| WARRANTY INFORMATION..... | PAGE 18 - 19 |

INTRODUCTION

GAME FEATURES

HOOP FEVER™ is a revolutionary concept in Coin Operated basketball games. You will see that this game includes many features which make it the obvious choice for your location

HOOP FEVER™ PLAY. **HOOP FEVER™** incorporates a STATIONARY basket that is user friendly and realistic. Fun and easy to play for players of all ages, yet challenging enough for even the expert basketball players. Practice your basketball skills and try to better your last score or compete against three other players.

CONTROL PANEL. Attractive LED displays are used to display all scoring and vital information such as time, credits and high score. The control panel is laid out in a convenient user friendly fashion, making it easy for players to operate.

HEAVY DUTY CONSTRUCTION is incorporated throughout the game by using only heavy gage metals and plastics. The game can be assembled and disassembled many times without any harm to the game. You will appreciate this feature if you move your games often.

HIGH TECH GAME ELECTRONICS. Solid state electronics are used throughout the game for their rugged reliability as well as making it virtually impossible to connect harnessing the wrong way. Heavy duty optical sensors are used throughout.

Digital sound effects are used for optimum dependability. Over twenty sound effects are incorporated into the sound effect circuitry. The game electronics have been highly integrated into the Main PC Board assembly, making it easy to repair games. The game has a full feature self-test system to make troubleshooting easier.

OPTIONS. A ticket dispenser and/or a dollar bill validator can be ordered with your game.

GAME PLAY

HOOP FEVER™ is an electromechanical coin operated amusement game designed to be played by one to four players.

HOOP FEVER™ is a game similar to the traditional basketball games already on the market. However, we have made this an even more exciting game. The net remains stationary as the player shoots over and over. Two points are awarded for each basket scored. When 10 seconds remain in the game, it awards the player three points for all baskets scored.

LINKING is a popular option used in locations where more than one game is to be used. The games are "linked" to add direct head to head action between the game players. This option is built into each Main PC Board, and is easy as connecting a phone line and setting a number in the programming mode.

ASSEMBLY

BEFORE YOU BEGIN

WARNING: WHEN INSTALLING THIS GAME, A 3 PRONG GROUNDED A.C. RECEPTACLE MUST BE USED. FAILURE TO DO SO COULD RESULT IN INJURY TO YOURSELF OR OTHERS. FAILURE TO USE A GROUNDED RECEPTACLE COULD ALSO CAUSE IMPROPER GAME OPERATION, OR DAMAGE TO THE ELECTRONICS

DO NOT DEFEAT OR REMOVE THE GROUNDING PRONG ON THE POWER CORD FOR THE SAME REASON AS GIVEN ABOVE. USING AN IMPROPERLY GROUNDED GAME COULD VOID YOUR WARRANTY.

HAVE A QUALIFIED ELECTRICIAN CHECK YOUR A.C. RECEPTACLE TO BE SURE THE GROUND IS FUNCTIONING PROPERLY.

TOOLS NEEDED

Before you start, you will need the following items:

- 7/16" Combination Wrench
- 7/16" Deep Well Socket
- Ratchet
- Side Cutters
- Adjustable Pliers
- #2 Square Drive Bit
- 5/32" Security Wrench

If you plan on moving your game often, or would like to speed up assembly, a cordless Drill is a good idea.

Your game requires a **MINIMUM CEILING HEIGHT** of 96" (8 feet). Check clearance before proceeding.

SET-UP

1. To begin, remove the game from the shipping containers.
2. Locate the main framework of the game. It may be easier to assemble if the framework is laid on its side.
3. Locate the two "U" shaped legs, and insert them into the bottom of the frame. At the front of the frame, use the set of holes closer to the bottom of the legs. At the rear of the frame, use the holes closer to the top of the legs. Secure with (4) 1/4-20 X 2 1/2" bolts, (8) flat washers and (4) Nylock nuts. (See Fig. 1)
4. Stand the frame up and move it into its permanent position. It is a good idea to carry the frame rather than slide it.

NOTE: IT WOULD BE A GOOD IDEA TO GET HELP WHEN LIFTING THE GAME TO THE UPRIGHT POSITION. THREE PEOPLE RECOMMENDED. THIS WILL KEEP THE GAME FROM SLIDING WHEN LIFTED.

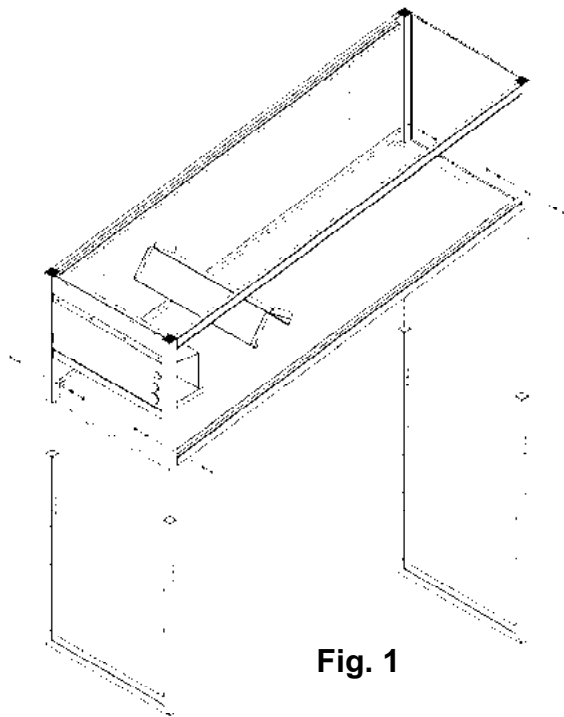

Fig. 1

5. Move the cabinet to the front of the frame and bolt it to the frame by installing the mounting bolts through the back of the front legs and into the front cabinet's mounting holes. Secure with (6) 1/4-20 X 3" security head Allen bolts and 6 flat black washers. (See Fig. 2)

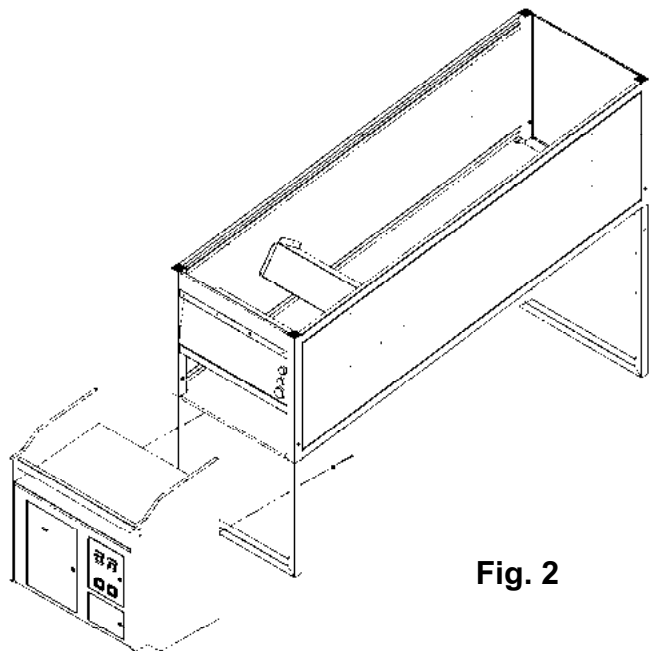

Fig. 2

6. Locate the harness that is tie wrapped up at the front of the frame. Cut the tie wrap and feed the harness through the frame and into the opening in the rear of the cabinet. Connect the harness to the connector located inside the cabinet.

ASSEMBLY

7. Assemble the mesh framework using the two large frame sides and the two connecting pipes supplied. Assemble using (4) 1/4-20 X 2" full thread bolts and (4) flat washers. (See Fig. 3)
- a) Feed the pipes through the tie wraps that are connected to the mesh.
- b) Separate the two frames until the pipes go between them.
- c) Start the bolts by hand, then secure with a wrench.

NOTE: Netting on frames not shown for clarity.

NOTE: DO NOT OVER TIGHTEN THE BOLTS IN THE PIPES, OR THE INSERTS COULD BE DAMAGED. BE CAREFUL NOT TO CROSS THREAD THE BOLTS IN THE PIPES.

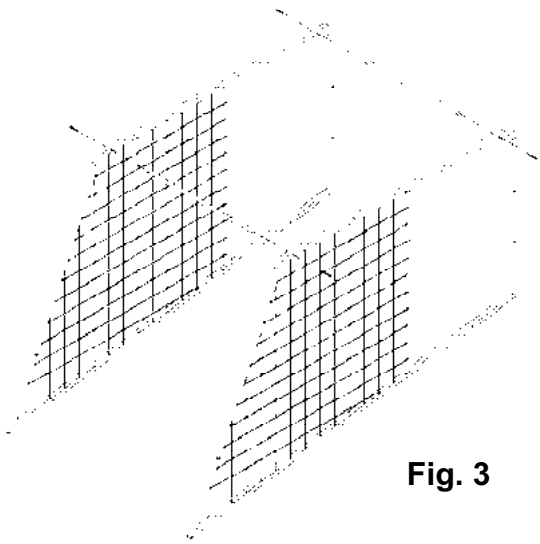

Fig. 3

8. Install the backboard with basket onto the side cages using the (8) 1/4-20 X 5/8" button head Allen cap screws supplied. (See Fig. 4)

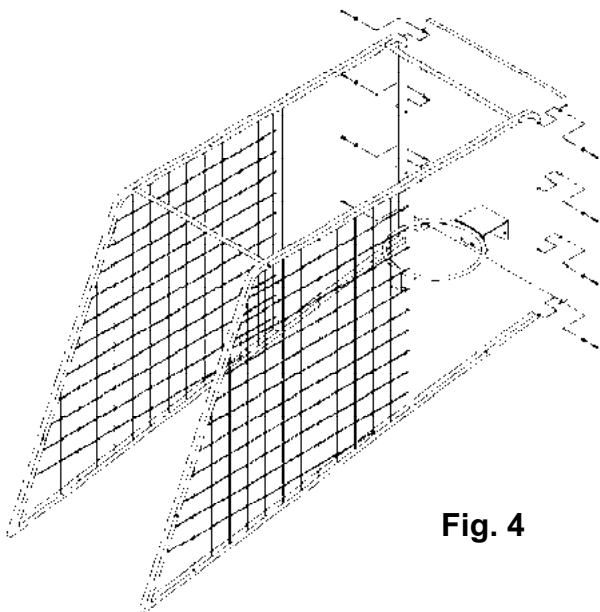

Fig. 4

NOTE: WHEN INSTALLING FOR A 9 FT. GAME, USE THE BOTTOM SET OF HOLES ON THE FRONT OF THE MESH FRAME, THE MIDDLE SET OF HOLES FOR A 8 1/2 FT. GAME AND THE UPPER SET OF HOLES FOR AN 8 FT. GAME. (WHEN SETTING UP AN 8 FT. GAME, YOU MAY WISH TO OMIT THE REBOUND GUARD)

9. Install the Frame assembly to the game. It can be adjusted to three heights: 9ft., 8 1/2 ft. and 8 ft. Please install to the highest possible height. Install by lifting the frame inside the game to one of the 3 sets of mounting holes, and secure with (4) 1/4-20 X 1 1/2" Allen head bolts, inserts and (4) flat black washers. (See Fig. 5)

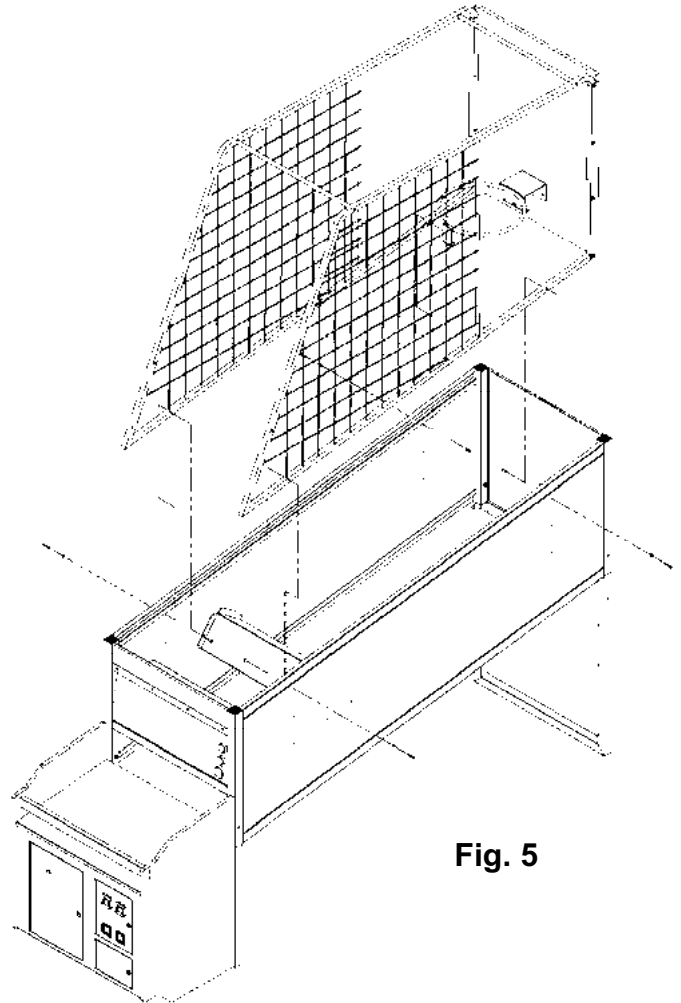

Fig. 5

10. Feed the sensor gray cable and ground wire into the backboard harness hole. Connect the four single pin mate-lock connectors from the gray sensor cable into the gray chassis cable, and the green/yellow wires that all run along the right hand side of the game. Connect the single pin mate-lock connectors as follows:

Green to White
Black to Black
Red to Red
Green/Yellow to Green/Yellow

ASSEMBLY

LINKING

11. Install the rebound guard using (2) 1/4-20 X 1 3/4" bolts, (4) flat washers and (2) Nylock nuts. (See Fig. 6)

For linking hook-up instructions, see Option #19 under "Customizing".

THANK YOU FOR YOUR PURCHASE OF THE
HOOP FEVER™ BASKETBALL GAME.

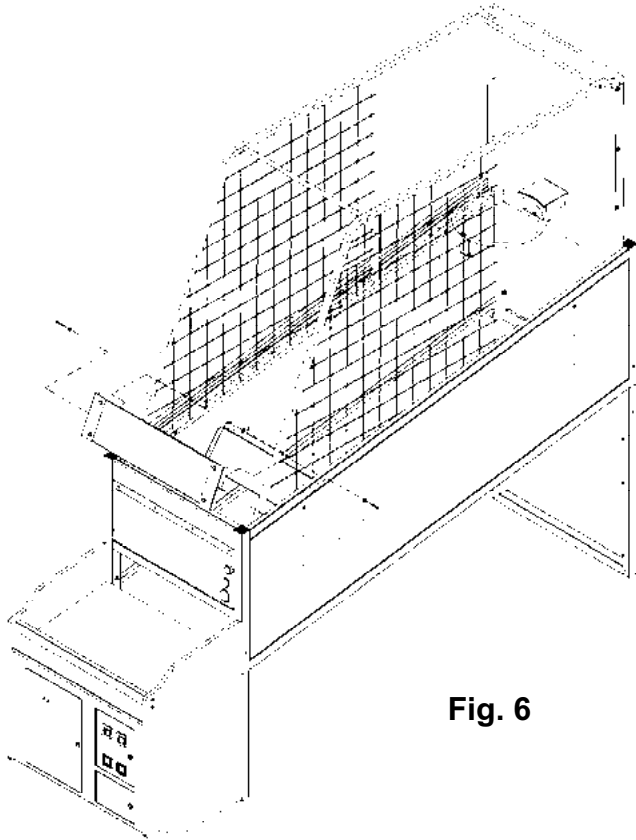

Fig. 6

12. Put the basketballs into the game. BE SURE THAT THEY ARE NOT OVER INFLATED. THIS COULD CAUSE THE BALL GATE TO OSCILLATE EXCESSIVELY.
13. Plug the game in and follow the game set-up procedures listed in this manual.
14. Open the control panel on the game by removing the 3 Allen head bolts and washers that secure the panel to the frame. Tilt the panel forwards, and connect the battery harness to the Main Board. The battery connector will be the only one loose in the cabinet. Reattach the control panel.
15. Test the game completely after set-up, and call our service department if you have any problems, questions or comments.

I.C.E. SERVICE DEPARTMENT

716-759-0360

NORMAL BUSINESS HOURS ARE:

MONDAY – FRIDAY, 8:30 AM TO 6:00 PM EST

CUSTOMIZING YOUR GAME

CUSTOMIZING YOUR GAME

This section will discuss subjects such as setting up credits, time per game, awards, etc. the section below will show how to enter into the programming mode and how to adjust many of the game's operating parameters.

ENTERING SET-UP MODE

You must enter set-up mode to adjust all of the game features. This can be accomplished in the following manner:

1. Open the game's coin door. This is the upper door located on the upper right side of the lower cabinet.
2. Locate the Counter / Programming button. It is located on the left hand side of the bracket that is attached to the cash box enclosure. The Counter / Programming button instruction decal is located on the cash box enclosure. This will give you a brief description of the features outlined below, as well as how to use them.
3. Press the Counter / Programming button.
4. If you wish to only read the "Counter", look at the "Player" displays to get the latest counter information. The display should be read from the bottom left (Player#4) position. Once you are done reading the counter, press the Counter / Programming button once again to return to game play.

CHANGING GAME SETTINGS

WHEN YOU PUSH THE Counter / Programming button, you will notice that along with the counter numbers shown in the "Player #" locations, there is a #1 shown in the "Credits / Time Left" display. This is the counter's "mode" number. Each programmable "mode" on the game has a number associated with it.

1. To advance through the different modes, press the "Start" button. Each push of the button will advance you to the next mode. Whenever you are done with any programming changes, push the Counter / Programming button to return to normal game play.
2. The current value for each mode will be shown in the "Player #4" location.
3. To change the shown value to a lower number, press the middle "Player Select" button.

PROGRAMMING

MODE #1 COUNTER

The counter is used to keep a running total of games played on the machine since it was first built. This counter is not re-settable unless power is removed from the battery backup on the PC Board. (small round battery)

NOTE: If power is removed from the PC Board, all other custom game settings will have to be re-entered.

MODE #2 COIN MECHANISM #1

This adjusts the amount of coins needed to receive 1 credit on the game's LEFT HAND COIN MECHANISM. Set this number to reflect how many coins per credit. Example: 2 Quarters per credit—enter the number 2.

MODE #3 COIN MECHANISM #2

This adjusts how many coins are required to receive 1 credit on the game's RIGHT HAND COIN MECHANISM. This mechanism is set differently, so it can be used for fractional credits. For normal use, set a "1" for this mode. If you wish to use this for coins with a different value than that of coin mech #1, contact our service department for set-up information for your particular application.

FREE PLAY

You can set your game up for free play by adjusting the coins per credit for coin 1 to "0".

MODE #4 CREDITS PER DOLLAR BILL

This option controls how many credits you will receive for each dollar bill inserted.

MODE #5 CURRENT CREDITS

This displays the credits currently in the game. You can manually remove or add credits to the game by changing the value of this number.

MODE #6 TIME PER CREDIT

This adjusts, in seconds, how long each game will last. The game can be adjusted from 20 to 99 seconds. The recommended time is 40 seconds.

CUSTOMIZING YOUR GAME

MODE #7 GAME POINTS PER AWARD

This adjusts how many tickets are given away for the game. The number displayed sets the points required to win an award. Setting this number to "0" will turn off the dispenser.

MODE #8 NOT USED

MODE #9 NOT USED

MODE #10 JUST FOR PLAYING

This feature is valuable in 2 respects.....

1. This can be set to any value desired, so that if a player, especially a young child who can not get the minimum points required to earn awards, can still be dispensed.
2. This setting can give a predetermined amount of tickets or cards per game, REGARDLESS of points scored, if the "points per award" and "winner" settings are set to "0".

MODE #11 AWARD THRESHOLD

This mode is used to set the minimum number of points needed to get any awards whatsoever. Set the number to match the score you wish to achieve before awards are dispensed. Setting this number to "0" turns the option off.

MODE #12 WINNER AWARDS

This setting is used by itself if you want the WINNER ONLY to get awards in a multiple player game. The number of awards dispensed is determined by the number selected. A setting of "0" will turn off this option. The winner awards are in addition to any other awards being dispensed.

MODE #13 NOT USED

MODE #14 ATTRACT MODE ON / OFF / TYPE

Use this setting to control the type of attract mode you would like. Setting a "1" gives you attract mode sound only. Setting a "0" turns the attract mode off.

MODE #15 ATTRACT INTERVAL

This determines the length of time between attract modes. Change this number to change the amount of time in MINUTES between attract modes. Setting this number to "0" turns this option off.

MODE #16 FREE GAME THRESHOLD

This option allows you to select a POINT THRESHOLD, where a free game will be awarded for the game. Once this threshold is reached, a FREE GAME will be awarded to the player, playing the game at that time. The free game is awarded immediately after completion of the paid game where the threshold had been broken.

Setting the value of this option to "0", turns the option off. Any other value sets that as the threshold value. We recommend 40 POINTS as a good starting point for the game.

MODE #17 NOT USED

MODE #18 NOT USED

MODE #19 LINKING STATION I.D.'S

NOTE: FAILURE TO OBSERVE THE INSTRUCTIONS LISTED BELOW WILL RESULT IN IMPROPER OPERATION OF ANY GAMES WHICH HAVE BEEN LINKED TOGETHER.

Each linked game must be connected with a modular phone line. Use no longer than a 12 ft. cord to link the games together.

Connect the games together by snapping a phone line jack on the back of the Main PC Board on the first game. Connect the cord to the jack on the back of the Main PC Board on the second game. When more than 2 games are linked, connect another phone cord to the back of the Main PC Board on the second game and run it to the preceding game and so on.

CUSTOMIZING YOUR GAME

When the linking option is used, each game must have it's own unique "I.D. Number" so that the games can properly link and talk to each other. Enter Mode #19 on all games, then set a number that is different for each game. The number used may be 0 through 13. the numbers 14 and 15 are reserved for the Jackpot Marquee. (Sold as a separate option)

Observe that game I.D.'s on all games are different, then exit programming mode on all games at the same time.

MODE #20 CREDIT DISCOUNTING

This mode enables the game to give the players an extra game when multiple coins are inserted. The number shown will be how many coins must be inserted for an extra game. Example: setting a "6" would mean that for every 6 coins inserted, an extra game would be given. Setting a "0" turns this mode off. The default value for this mode is "0".

MODE #21 NOT USED

MODE #22 BEACON LIGHT POINT THRESHOLD

This option allows you to select a point threshold, where the optional point beacon light will turn on. Once this point threshold value is reached, the beacon light will turn on.

Setting the value to "0" turns the option off. Any other value sets that as the threshold value.

NOTE: WHEN SETTING UP MULTIPLE GAMES IN THE SAME LOCATION, IT IS A GOOD IDEA TO TURN THE ATTRACT MODE OFF ON ALL BUT 1 GAME.

BURN IN SELF TEST MODE

This allows you to enter the BURN-IN SELF TEST MODE, which can be very handy in problem diagnostics. To enter this mode, press and hold the GAME SELECT and START buttons at the same time WHEN IN MODE #1.

Perform the following tests when in this mode:

1. Press the face panel push buttons to check for their proper operation. An audible sound will be heard if working properly.

2. The face panel push buttons should light if they are working correctly.
3. Move the coin mech micro switch wires. An audible sound will be heard if they are working correctly.
4. Throw a ball into the basket. If the sensor is working correctly, an audible sound will be heard.

To exit the self test mode, press the "Counter / Programming" button inside the coin door.

GAME TESTING

It is easy and advisable to test your game after installation. After the game is set up and all options have been set up correctly, perform the following tests:

1. Test for proper acceptance of money.
2. Test for proper dispensing of tickets, if you have set that option.
3. Test for proper game play, including proper scoring.
4. Test for proper retention of game memory, when the game power is shut off and turned back on.
5. Be sure to check your electronic game counter and write down any information you may wish to record.
6. When testing linked games, be sure all of the game scores show up properly.

QUICK TROUBLESHOOTING

| PROBLEM | PROBABLE CAUSE | SOLUTION |
|---|--|--|
| NO SPOTLIGHT | BAD FUSE AT POWER MODULE GAME UNPLUGGED TRIPPED CIRCUIT BREAKER DAMAGED POWER CORD BURNED OUT BULB GAME WIRING BAD | INSPECT MAIN FUSES CHECK POWER CORD CHECK BREAKER BOX REPLACE CORD REPLACE BULB CHECK WITH VOLTMETER |
| BALL GATE WILL NOT OPEN OR CLOSE | BAD OR LOOSE MICROSWITCH BAD FUSE ON MAIN PC BOARD BAD WIRING TO SWITCH OR MOTOR BAD MAIN PC BOARD BAD GEAR BOX BALL GATE STOP IMPROPERLY SET | CHECK OR RETIGHTEN CHECK ALL FUSES CHECK WITH VOLTMETER REPAIR OR REPLACE PC BOARD REPLACE GEAR BOX RE-ADJUST UNTIL CAM TOUCHES MICROSWITCH |
| PUSHBUTTONS DO NOT LIGHT OR WORK PROPERLY | BAD BULB IN BUTTON BAD MICROSWITCH IN BUTTON BAD WIRING TO MAIN PC BOARD BLOWN FUSE ON MAIN PC BOARD BAD MAIN PC BOARD BUTTON STUCK SHUT | CHANGE LIGHT BULB REPLACE MICROSWITCH CHECK WITH VOLTMETER CHECK ALL FUSES REPLACR MAIN PC BOARD REMOVE AND CLEAN BUTTON |
| BALLS DO NOT SCORE CORRECTLY | BAD SENSOR SENSOR DIRTY REFLECTIVE STRIP DIRTY BAD HARNESSING OR WIRING BAD MAIN PC BOARD BAD BATTERY | REPLACE SENSOR CLEAN (USE NO SOLVENTS) CLEAN (USE NO SOLVENTS) CHECK WITH VOLTMETER REPLACE MAIN PC BOARD CHECK CHARGING CIRCUIT OR REPLACE BATTERY |
| GAME DOES NOT TAKE OR ADD MONEY CORRECTLY | BAD MAIN PC BOARD BAD MICROSWITCH OR DBV BAD WIRING TO MICROSWITCH OR DBV GAME PROGRAMMING SET WRONG | REPLACE MAIN PC BOARD REPLACE SWITCH OR DBV CHECK WITH VOLTMETER RESET GAME PROGRAMMING |
| GAME DOES NOT DISPENSE TICKETS CORRECTLY | BAD TICKET DISPENSER BAD WIRING TO DISPENSER OUT OF TICKETS TICKET SENSOR IS DIRTY DISPENSER JAMMED GAME PROGRAMMING SET WRONG BAD MAIN PC BOARD | REPLACE TICKET DISPENSER CHECK WITH VOLTMETER ADD TICKETS CLEAN SENSOR ON DISPENSER REMOVE TICKET JAM RESET PROGRAMMING REPLACE MAIN PC BOARD |
| NO OR LOW GAME SOUND | VOLUME TURNED DOWN DEFECTIVE VOLUME POT BAD SPEAKER BAD WIRING TO MAIN PC BOARD BAD MAIN PC BOARD | TURN UP VOLUME REPLACE POT REPLACE SPEAKER CHECK WITH VOLTMETER REPLACE MAIN PC BOARD |
| BALLS DO NOT DISPENSE QUICKLY ENOUGH OR JAM IN THE GAME | GAME HAS EITHER TOO MANY OR TOO FEW BALLS | GAME IS DESIGNED TO WORK WITH 7 BALLS |
| ALARM GOES OFF FREQUENTLY | BALL GATE CAN NOT CLOSE BALL SENSOR WORKING INCORRECTLY BAD MAIN PC BOARD BALLS JAMMED IN GATE | (SEE BALL GATE) (SEE BALL SENSORS) REPLACE MAIN PC BOARD TOO MANY BALLS IN GAME |
| DISPLAY LED'S DO NOT WORK PROPERLY | BAD MAIN PC BOARD BAD FUSE ON MAIN PC BOARD | REPLACE PC BOARD CHECK ALL FUSES |
| GAME WILL NOT RETAIN CUSTOM PROGRAM SETTINGS | BAD MAIN PC BOARD BAD OR WEAK MEMORY BATTERY | REPLACE PC BOARD REPLACE BATTERY ON MAIN PC BOARD |
| LINKED GAMES NOT SCORING OR WORKING CORRECTLY | GAME ID'S SET THE SAME | CHANGE ALL GAMES TO DIFFERENT ID NUMBERS |

MAINTENANCE & TROUBLESHOOTING

OPERATIONAL BACKGROUND

The following will outline the basic operating principles of the **HOOPS FEVER™** basketball game.

The game incorporates a Reflex Photoelectric polarized sensor detection system for counting balls that go through the hoop.

The ball gate uses micro switches to determine positioning of the gate, which are activated by the cam on the ball gate shaft.

The gear motor uses a combination of hardware and software control to protect against over current damage. When an over current condition is detected, the motor will shut off automatically. The game microprocessor will then decide whether or not the motor should be turned on. It will also determine at that time which way the motor should run.

MECHANICAL REPAIR

IMPORTANT: USE ONLY ICE REPLACEMENT PARTS WHEN SERVICING YOUR GAME. USING NON-ICE APPROVED PARTS COULD VOID YOUR WARRANTY, AND COULD CAUSE SERIOUS DAMAGE TO THE GAME OR INJURY TO OTHERS.

IF YOU HAVE ANY QUESTIONS REGARDING REPAIR AFTER READING THIS SECTION, CALL OUR SERVICE DEPARTMENT BEFORE PROCEEDING AT:

I.C.E. SERVICE DEPARTMENT

716-759-0360

NORMAL BUSINESS HOURS ARE:

MONDAY – FRIDAY, 8:30 AM TO 6:00 PM EST

BALL GATE SERVICE:

- Remove both battery and AC power
- Unfasten the (6) square drive screws and remove the ball gate housing, located on the right hand side of the ball gate assembly.
- Unbolt the control panel from the front of the game to gain access to the control panel.
- Unplug the two mate-lock connectors (2 pin connector with the yellow/black and brown/white wires and the three pin connector with the red, black and blue wires) located to the right of the transformer. Cut any tie-wraps holding the harnessing.
- Remove the two bolts that hold the ball gate bearing in place, located on the left hand side of the assem-

bly. (Hint: a long extension on a ratchet can be helpful for this operation.)

- Pull the ball gate from the end by the bearing towards you. (the front of the game)
- The gear motor can now be pulled away from the retaining bracket.
- Remove the two Allen head set screws to remove the ball gate from the gear motor.
- **NOTE:** When removing wires from the micro switches or motor, it is **VERY** important to make sure all wires are returned to their proper terminals. Failure to do so will result in improper operation of the ball gate and could damage the game. The wires are color coded so it will be easy to document where each wire goes.
- **IMPORTANT:** Mark the position of the micro switch mounting bracket so that the switch actuators will line up correctly with the cam on the ball gate when the unit is re-assembled.
- Use thread locking compound on the Allen head set screws when re-assembling the ball gate to the gear motor.
- Assemble in reverse order of disassembly. Tighten all hardware securely.
- Re-test for proper operation
- Temporarily shut off AC power, reconnect battery and turn AC power back on.

LIGHT BULB REPLACEMENT:

- **WARNING: TURN OFF GAME POWER BEFORE REPLACING THE LIGHT BULB.**
- Replace the bulb by removing the screws that secure the control panel to the game. Carefully remove the control panel, and set it on the front of the game. Replace the light bulb and install the control panel to the game.

REPLACEMENT BULB:

110 WATT ROUGH SERVICE SPOTLIGHT

HOOP SENSOR REPLACEMENT:

- Turn off all AC power to the game and unplug the battery back-up circuitry. (disconnect the 2 pin mate-lock connector from the PC Board)
- Standing in the ball return tray, unscrew the (4) screws and Nylock nuts that hold the two sensor(s) to their sensor bracket(s).

MAINTENANCE & TROUBLESHOOTING

- Disconnect the (3) (green, red and black wires) single mate lock connectors from the gray sensor cable behind the backboard. Remove the gray wire feeding through the backboard harness hole. Remove the sensor assembly. Note how the sensor cable feeds through the basket net loops.
- Remove the sensor(s). The two sensors are held onto the sensor bracket by (4) #6-32 X 1/2" hex spacers.
- Replace with new sensor assembly using the previous directions in reverse.

MECHANICAL MAINTENANCE

IMPORTANT: FOLLOW THE SUGGESTED MAINTENANCE TO ENSURE THE BEST OPERATION POSSIBLE FOR YOUR GAME.

GENERAL CLEANING

Clean the surfaces of the cabinet and decals with a commercial cleaner such as 409™ or Fantastic™. Do NOT use cleaners such as Wildcat pinball cleaner or alcohol. It can take the finish off of the decals. Use Pledge™ on all plastic and painted surfaces. This product works especially well on clear plastics. Please note that other spray polishes do not work as well.

BASKETBALLS

The basketballs should be checked every week for proper inflation. A bicycle tire pump and inflating needle can be purchased at any sporting goods store and most large discount stores.

Keeping the balls properly inflated will make it more difficult to pull them past the ball gate. It will also create more realistic basketball action when interacting with the hoop. Any 8" basketball will work with this game.

NOTE: DO NOT OVER-INFLATE THE BASKETBALLS. THIS CAN CAUSE DAMAGE TO THE BALL AND SHORTEN THE LIFE OF THE BALLS.

ELECTRONIC AND ELECTRICAL REPAIR

The following section will describe repair procedures and trouble shooting hints for the game electronics.

Please read the section "Operational Background" in the beginning of Maintenance and Trouble Shooting to get a

good understanding of the game's basic operating parameters.

WARNING: EXERCISE CAUTION WHENEVER WORKING WITH ELECTRONICS, THEY CAN BE VERY SUSCEPTIBLE TO DAMAGE FROM SHORT CIRCUITING, OR PHYSICAL ABUSE. ALWAYS UNPLUG THE GAME WHEN WORKING ON HIGH VOLTAGE AREAS OF THE GAME, SUCH AS THE TRANSFORMER.

USE EXTREME CAUTION WHEN USING VOLTME-TERS TO DO CIRCUIT CHECKS IF THE GAME POWER HAS BEEN LEFT ON.

ALWAYS REMOVE THE BATTERY BACK-UP POWER WHEN WORKING ON THE GAME. THIS IS NECESSARY AS SOME CIRCUITS ARE CONSTANTLY UNDER POWER FROM THE BATTERY.

WHEN USING A VOLTMETER, BE SURE IS SET TO THE CORRECT VOLTAGE OR RESISTANCE RANGE BEFORE USING. THIS CAN PREVENT POSSIBLE DAMAGE TO THE PC BOARD OR MISDIAGNOSIS.

ALWAYS REMOVE POWER TO THE GAME WHEN PLUGGING OR UNPLUGGING PC BOARDS.

IT IS NECESSARY TO USE ICE REPLACEMENT PARTS TO CONTINUE WARRANTY COVERAGE. USE OF NON-ICE APPROVED PARTS WILL NOT ONLY VOID YOUR WARRANTY, BUT COULD CAUSE SERIOUS HARM TO THE GAME, OR CAUSE SERIOUS BODILY INJURY.

IF YOU HAVE ANY QUESTIONS REGARDING REPAIR AFTER READING THIS SECTION, CALL OUR SERVICE DEPARTMENT BEFORE PROCEEDING AT:

I.C.E. SERVICE DEPARTMENT
716-759-0360

NORMAL BUSINESS HOURS ARE:
MONDAY – FRIDAY, 8:30 AM TO 6:00 PM EST

FUSES

Fuses are the first items that should be checked when the game is inoperable or works incorrectly.

There are 5 fuses in the game. Two fuses are located in the electronics control panel on a fuse block to the right of the fan, above the transformer.

To check or service the fuses, FIRST REMOVE THE POWER CORD. FAILURE TO DO SO COULD RESULT IN SERIOUS INJURY OR DEATH. Using a small flat blade screwdriver, pry the fuse from the fuse block. Pull the fuse from the fuse block and test the fuses. Be sure to replace the fuses with the same type and value.

MAINTENANCE & TROUBLESHOOTING

There are 3 fuses located on the Main PC Board. These fuses protect the low voltage sides of the game, the 5 volt and 12 volt sides, AC & DC. Be sure game power is off when checking or replacing these fuses. Replace the Main PC Board fuses with the original type and value. USE SLO-BLO MDQ TYPE fuses only. Other types of slo-blo fuses may cause unexpected problems with the game.

TRANSFORMER

ALL AC POWER MUST BE REMOVED FROM THE GAME WHEN SERVICING THIS COMPONENT. IT IS A GOOD IDEA TO ACTUALLY REMOVE THE POWER CORD FROM THE WALL OR FLOOR OUTLET WHEN CHANGING THE TRANSFORMER.

CAREFULLY document where each color wire goes BEFORE removing any wires.

Remove the 4 screws that hold the transformer to the game frame.

Replace and reconnect the transformer.

TAKE ANY FAST-ONS THAT WERE ON THE OLD TRANSFORMER COVERING THE UNUSED AC TERMINALS OFF AND TRANSFER THEM TO THE NEW TRANSFORMER. THIS IS NECESSARY AS THE LEADS ON THE TRANSFORMER HAVE POWER ON THEM.

CHANGING AC VOLTAGES

When you receive your game from the factory, it should be set to the proper AC voltage. If for some reason however, it needs to be set to a different AC voltage, follow these directions.

Unplug the game from the AC outlet.

The AC input taps for the transformer are located on the front left hand side of the transformer, as viewed from the opening of the access door.

The AC taps can be further identified by the fact that there are 5 taps in a row. (The only place on the transformer where there are 5 taps in a row.)

The bottom tap is the 0 volt tap. One side of the AC line should always be left attached to this terminal.

The 5 taps FROM THE BOTTOM OF THE TRANSFORMER UP are as follows:

240 VAC
210 VAC
115 VAC
90 VAC
0 VAC

These numbers are also indicated on the transformer itself.

The AC wire that is on one of the above taps is the only wire you should move. Please use a blank fast-on, on any open terminals, to protect against shock hazards.

MAIN PC BOARD

IMPORTANT: BEFORE REMOVING THE MAIN PC BOARD OR CHANGING THE MEMORY BATTERY, GO INTO THE OPTIONS MODE AND RECORD YOUR COUNTER AND GAME SETTINGS, SO THEY CAN BE RE-ENTERED AFTER SERVICING HAS BEEN COMPLETED.

The Main PC Board is located on the back of the Control Panel. Remove the 3 bolts that hold the panel to the game and flip the Control Panel out.

Remove all AC power before removing the Main PC Board.

Disconnect all mate-lock connectors from the PC Board.

Remove the 6 retaining fasteners and remove the PC Board.

Install in the reverse order.

If you are installing a new memory battery or new PC Board, after installation, reset all custom game programming into system memory.

BALL SENSORS

The ball sensors are a through beam infra-red pair. To test, walk into the game, and pass a ball through the hoop when a game is being played.

NOTE: DO NOT USE YOUR HAND TO TEST THE SENSOR, AS THE INFRA-RED BEAM CAN USUALLY SEE THROUGH A HAND, AND WILL NOT GIVE YOU AN ACCURATE TEST.

When you pass the ball through the hoop, you should hear the swish sound from the game. If you hear the sound, the sensors are good.

If you do not hear the sound, check the transmitter sensor with an I.R. Detector card. (Radio Shack part no. 276-099) The transmitter is the unit with the lit LED in it. If you do not see any reflected I.R. light, do a voltage check to be sure the sensors are receiving power. If the sensors are not receiving power, fix the power problem and proceed.

MAINTENANCE & TROUBLESHOOTING

If you see reflected I.R. light, perform a continuity check to make sure the signal from the I.R. receiver is getting back to the Main PC Board.

If you have no reflected light and it has been established that there is power, you have a defective TRANSMITTER.

If you have reflected light and have established that the wiring between the receiver and Main PC Board is good, there is a high probability that the receiver is bad.

There is one final check you can make to be sure the problem is not on the Main PC Board. Use a wire jumper or paper clip and jump between pins 12 & 14 on the P5 connector of the Main PC Board. If you do this when a game is in progress, a “swish” sound should be heard each time you MOMENTARILY jump those terminals. If the sound is heard, and the wiring to the sensor is good, and the transmitter works correctly, then the receiver is definitely bad.

If you need to replace either of the sensors, refer to the “Hoop Sensor Replacement” section in the mechanical repair area for directions on how to replace the sensors.

OPTIONAL ACCESSORIES

OVERVIEW

IF YOU DO NOT FIND ANSWERS TO YOUR QUESTIONS IN THIS SECTION, REFER TO THE ACCOMPANYING MANUAL FOR YOUR PARTICULAR PRODUCT, OR CALL OUR SERVICE DEPARTMENT.

I.C.E. SERVICE DEPARTMENT **716-759-0360**

NORMAL BUSINESS HOURS ARE:
MONDAY – FRIDAY, 8:30 AM TO 6:00 PM EST

TICKET DISPENSER

Refer to the supplied service manual for all information other than software settings.

The ticket dispenser comes pre-set from the factory to dispense 1 ticket for every 5 points scored. In addition to this, if the game player did not score enough points to get 1 ticket, the game is preset to give the player 1 ticket "just for playing".

These settings can be adjusted by changing the ticket options in the "GAME OPTIONS" mode. If you change the memory battery or Main PC Board, you may have to reset the value for these options.

You can also set the game up so that the winner of MULTIPLE player games ONLY, wins tickets or that a certain amount of points must be scored BEFORE ANY tickets will be dispensed. This is the threshold option.

DOLLAR BILL VALIDATOR

Refer to the supplied manual for all information other than software settings.

The validator normally requires no adjustments other than checking to see that the proper voltage is present. This Validator runs on 12 volt DC power, with a minimum of 11.5 volts DC. The Validator will not work correctly with voltages below that specified.

The validator may work improperly or not at all if it is not grounded properly.

The unit should be cleaned periodically to ensure proper operation. Blow out as much dirt as possible. Then use a cotton swab (Q-Tip) to get into the front opening to remove any remaining dirt or debris. Clean the stacker belts with a rubber rejuvenator. Clean any other dirt from the unit with isopropyl alcohol.

That game comes from the factory pre-set at 2 credits per bill. You can change this by entering the "GAME OPTIONS" screen. (see GAME OPTIONS settings section for more information)

ABOUT LINKING

With LINKING it will be possible for your customers to enjoy exciting Head to Head competition when two or more **HOOP FEVER™** games are connected together. In fact, you can link as many as fourteen **HOOP FEVER™** games together.

Game linking is accomplished through the “Link” button located in the upper right hand corner of the control panel. When enough money is inserted into the game to create one or more credits, the “Link” button will begin to flash. If a player on another game pushes their “Link” button, the games are now linked together. Once the games are linked together, they become 1 player only games. When any of the players push the “Start” button, the game begins.

When the game is over, the top four players are ranked on the display. The game spotlight will flash for the winner.

TICKET SETTINGS

Ticket settings will work in the same fashion as a regular **HOOP FEVER™** game. Be sure all of the games linked together are set EXACTLY the same. Using different settings could yield unexpected results.

NOTE: WHEN LINKING 1 OR MORE GAMES TOGETHER, IT IS ADVISIBLE TO TURN THE ATTRACT MODE OFF ON ALL BUT 1 GAME. THIS WILL ELIMINATE STRANGE SOUNDS FROM MORE THAN 1 ATTRACT MODE PLAYING, BUT NOT AT THE SAME TIME.

PARTS LISTINGS

MECHANICAL PARTS

| | |
|----------|---------------------------------|
| HF1005 | Coin door panel, frame |
| HF1006X | Coin door assembly |
| HF1007 | Accessory door |
| HF1008 | Cash box door |
| BB1009 | Cash box enclosure (galvanized) |
| HF1017 | Cover IR emitter |
| HF1018 | Cover IR receiver |
| HF1019 | Bracket (backboard side) |
| HF1039 | Hoop (15 inch) |
| HF1054 | Frame, red |
| HF1055 | Mesh frame side |
| HF1058 | Ball stop rail |
| HF1060 | Ball deflector |
| HF1062 | Rebound guard mounting bracket |
| HS3001 | Basketball B110 |
| HF3052 | Backboard |
| SF3008 | Basketball net |
| BT3009 | Frame netting |
| BB5001 | Cash box |
| 5014 | Door lock |
| 6459 | Allen wrench (security) |
| PC60615A | #2 square drive bit |

GRAPHICS & DECALS

| | |
|--------|---------------------------------------|
| HF7001 | Programming decal |
| HF7002 | Backboard overlay |
| HF7005 | Front cabinet decal |
| HF7008 | Decal I.C.E. logo |
| 7031 | "Suitable for indoor use only" decal |
| 7032 | "Caution replace fuse.....) decal |
| 7033 | "Warning disconnect power.....) decal |
| 7035 | "On/off" decal |
| 7037 | "5 amp fuse" decal |
| 7039 | "Caution hot surface" decal |
| 7041 | "6 amp warning" decal |
| HF9001 | Service manual |

ELECTRICAL & ELECTRONIC PARTS

| | |
|----------|--------------------------------|
| 2007 | Speaker |
| 2364X | Fan assembly |
| HF2034X | Main P.C. Board |
| BT2002 | Transformer |
| BB2005 | Micro switch |
| BB2008 | Ball gate motor (3269) |
| HF2003X | Photoelectric transmitter |
| HF2003RX | Photoelectric receiver |
| HF3004X | Net sensor assembly |
| PC20407 | Battery, 3.2 volt |
| BT2027X | 20 ft. line cord |
| BB2023 | Long life lamp bulb (5000 hr.) |

Warranty

I.C.E warrants all components in the **HOOP FEVER™** game to be free of defects in materials and workmanship for a period of ninety days from the date of purchase.

This warranty does not cover items damaged due to normal wear and tear, subjected to abuse, improperly assembled by the end user, modified, repaired, or operated in a fashion other than that described in the service manual.

If your **HOOP FEVER™** game fails to conform to the above-mentioned warranty, I.C.E.'s sole responsibility shall be at its option to repair or replace any defective component with a new or remanufactured component of equal to or greater O.E.M. specification.

I.C.E. will assume no liability whatsoever, for costs associated with labor to replace defective parts, or travel time associated therein.

I.C.E.'s obligation will be to ship free of charge, replacement parts by U.P.S. Ground, U.S. mail, or other comparable shipping means. Any express mail or overnight shipping expense is at the cost of the purchaser.

Products will be covered under warranty only when:

- The serial number of the game with the defective parts is given.
- The serial number of the defective part, if applicable, is given.
- Defective parts are returned to I.C.E., shipping pre-paid, in a timely fashion, if requested by I.C.E.
- A copy of the sales receipt is available as proof of purchase upon request of I.C.E.

I.C.E. distributors are independent, privately owned and operated. In their judgment, they may sell parts or accessories other than those manufactured by I.C.E. We cannot be responsible for the quality, suitability, or safety of any non-I.C.E. part, or any modification, including labor, which is performed by such a distributor.



WARRANTY

ICE Inc warrants that all of its products will be free from defects in material and workmanship.

When placing a warranty request, please be prepared to provide the following information:

- Serial Number of Game or Bill of Sale
- Machine Type
- A Detailed Description of the Equipment Fault Symptoms

ICE product, including Cromptons, Sam's Billiards, Uniana and Bell Fruit is warranted as follows:

- 180 days on the Main PCB and Computers
- 180 days on Motors
- 90 days on all other components (i.e. DBV's, Ticket Dispensers, etc)
- 30 days on repaired items
- 3 years on all Crane Harnessing
- 9 Months on Printers

ICE Inc shall not be obligated to furnish a warranty request under the following conditions:

- Equipment has been subjected to unwarranted stress through abuse or neglect
- Equipment has been damaged as a result of arbitrary repair/modification attempts
- Equipment that has failed through normal wear and tear

ICE Inc will assume no liability whatsoever for costs associated with labor to replace defective parts or travel time associated therein.

All defective warranty covered components will be replaced with new or factory refurbished components equal to OEM specifications. ICE Inc will cover all UPS ground, or comparable shipping means, freight costs during the warranty period. Expedited shipments are available for an additional charge.

Defective parts are returned to ICE Inc, at the customer's expense, in a timely fashion.

ICE distributors are independent, privately owned and operated. In their judgment, they may sell parts and/or accessories other than those manufactured by ICE Inc. We cannot be responsible for the quality, suitability or safety of any non-ICE part, modification (including labor) that is performed by such a distributor.

I.C.E. Parts/Service Dept.
Innovative Concepts in Entertainment
10123 Main St.
Clarence, NY 14031
Phone #: (716) - 759 - 0360
Fax #: (716) - 759 - 0884