

# Come on down!

**You're the Next Contestant on...**



**\* First Ever Licensed Pusher  
Built & Priced in the **

**\* Skill Slide Coin Entry**

**\* 1 Year Warranty  
on Pusher Motor &  
Main Board**



**Ticket "Drawer" Makes  
Loading Tickets & Other  
Operator Adjustments Easy!**

Dimensions: 31" d x 41" w x 87" h  
Weight: 500 lbs.

THE PRICE IS RIGHT is a trademark of FremantleMedia Operations BV. © 2008 FremantleMedia North America, Inc. All Rights Reserved. Based on the FremantleMedia television program 'The Price is Right'. Licensed by FremantleMedia Enterprises [www.fremantlemedia.com](http://www.fremantlemedia.com).



Innovative Concepts in Entertainment • 10123 Main Street • Clarence, New York 14031  
Phone: 716-759-0370 Fax: 716-759-0390 • Email: [play@icegame.com](mailto:play@icegame.com) • Visit: [www.icegame.com](http://www.icegame.com)



# TABLE OF CONTENTS

<b>Safety and Warnings</b>	3
<b>Setup</b>	
Game Play Feature	4
Meters	5
Programming	5 & 6
Errors	6
Playfield	7
<b>Trouble Shooting</b>	
Security Slam Switches	8
Power supply	9
<b>Assembly Diagrams</b>	
Cabinet PE1000X	10 - 11
Big Bonus Wheel PE3110X	12 - 14
Skill Coin Chute PE1006X	15 - 16
Ticket Drawer PE3011X	17 - 18
Programming Console PE3011X	19
Coin Drawer PE1009X	20
Playfield Deck PE3130	21-23
Deck PE3076	24 - 25
Cabinet Layout PE1100X	26
Marquee PE3127X	27
<b>Spares</b>	29
<b>Wiring Diagrams</b>	See Insert
<b>Main Logic Board Connector Layout</b>	30
<b>Warranty</b>	31

# SAFETY AND WARNINGS

## BEFORE YOU BEGIN

WARNING: WHEN INSTALLING THIS GAME, A GROUNDED A.C. RECEPTACLE MUST BE USED. FAILURE TO DO SO COULD RESULT IN INJURY TO YOURSELF OR OTHERS. FAILURE TO USE A GROUNDED RECEPTACLE COULD ALSO CAUSE IMPROPER GAME OPERATION, OR DAMAGE TO THE ELECTRONICS. DO NOT DEFEAT OR REMOVE THE GROUNDING PRONG ON THE POWER CORD FOR THE SAME REASON AS GIVEN ABOVE. USING AN IMPROPERLY GROUNDED GAME COULD VOID YOUR WARRANTY. HAVE A QUALIFIED ELECTRICIAN CHECK YOUR A.C. RECEPTACLE TO BE SURE THE GROUND IS FUNCTIONING PROPERLY. DO NOT WASH YOUR GAME WITH A PRESSURE WASHER.

AVERTISSEMENT: lors de l'installation de ce jeu, la terre AC réceptacle doit être utilisée. Ne pas le faire pourrait entraîner un préjudice à vous ou à d'autres. Le non-recours à la terre réceptacle pourrait également causer une mauvaise opération de jeu, ou les dommages causés à l'électronique. NE PAS détériorer ou de retirer la broche de terre sur le cordon d'alimentation pour la même raison, comme indiqué ci-dessus. Indûment l'aide d'un jeu de la terre pourrait annuler votre garantie. Ont un électricien qualifié de vérifier votre réceptacle AC pour s'assurer que le sol fonctionne correctement. Ne lavez pas votre jeu avec une laveuse à pression.

## INSTALLATION

The game comes ready to play with just a few simple things to keep in mind.

1. Plug the game into the A.C. outlet and turn on power to the game. The switch for the game is located on a power module on the outside rear of the game.

THIS GAME IS DESIGNED TO DISSIPATE STATIC ELECTRICITY THROUGH THE GROUNDING PLANE OF THE GAME. IF THE A.C. GROUND DOES NOT WORK, THE GAME COULD DISCHARGE STATIC ELECTRICITY THROUGH THE GAME CIRCUITRY, WHICH COULD CAUSE DAMAGE.

2. Make sure the game is level after installation. It is necessary to make sure the game is level for safety concerns.
3. Check that the A.C. voltage rating on the back of the game matches the A.C. voltage of your location.

THE POWER SUPPLY IS NOT VOLTAGE ADJUSTABLE. TO OPERATE THE GAME AT VOLTAGES OTHER THAN THOSE IT WAS DESIGNED FOR. PLEASE CONTACT OUR SERVICE DEPARTMENT FOR VOLTAGE CONVERSION INFORMATION.

## WARNING

DO NOT remove any of the components on the main board (e.g. compact flash and eproms) while the game is powered on. This may cause permanent damage to the parts and the main board. Removing any main board component part while powered on will void the warranty.

Ne retirez pas l'un des composants sur la carte principale (par exemple Compact Flash et EPROMs), tandis que le jeu est sous tension. Cette mai causer des dommages permanents aux parties et la carte principale. Suppression de tout bord principal élément sous tension alors que annulera la garantie.

**NOTE: THIS GAME IS INTENDED FOR INDOOR USE ONLY.**

**ON THE BACK PANEL OF THE GAME: WARNING: SHOCK HAZARD - DO NOT OPEN. REFER SERVICING TO SERVICE PERSONNEL.**

**REMARQUE: CE JEU EST DESTINÉ POUR USAGE À L'INTÉRIEUR SEULEMENT.**

**SUR LE PANNEAU ARRIÈRE DU JEU: AVERTISSEMENT: RISQUE DE CHOC - NE PAS OUVRIR. RÉPARATION À UN PERSONNEL DE SERVICE.**

# SETUP - INTRODUCTION

## Game play:

The player starts the game by moving the coin chute to skillfully drop their coin to light up the word "PLINKO". As the coin falls it is deflected off the pegs just like on the TV show. If the player is able to light the word "PLINKO", they are able to spin the big bonus wheel! Players receive tickets for coins that fall over the edge and in some cases, just for playing!

- Bonus wheel emulates "The Price is Right Big Wheel Spin".
- Playfield replicates the real "PLINKO!" board as seen on TV.
- Spell PLINKO! by lighting each letter for a chance to win the Big Bonus.
- Move coin chute back and fourth for skillful aiming.
- Win tickets for coins over the edge.
- Win tickets just for playing (Operator configurable).

## Features:

- Ability to set pre-lit letters.
- Ability to turn on chasing lights.
- Ability to set mercy tickets and coin over edge.
- Adjustable bonus feature (how much to apply toward the bonus).
- Easy slide pull out ticket door to access.
  - Ticket dispensers.
  - Coin and ticket meters.
  - Operator adjustments.
  - Error codes.
- High reliable playfield motor with 1 year warranty.
- Easy to program.
- Self error/fault checking.
- Slam security switch on each station.
- Tilt protection.
- Made in the USA.

# SETUP - ASSEMBLY

## METERS AND TICKET DISPENSER LOCATION

The coin and ticket meters are located in lower cabinet drawer of each station. Unlock both locks on each side and slide the drawers out. There you will find the ticket dispenser and meters.

## ACCESSING PROGRAMMING CONSOLE

The programming console unit pictured below has four buttons and a digital display screen. This is located in the left ticket and hopper drawer assembly. Unlock the two locks to slide the left drawer open. The console is located on the right side of that drawer only. Refer to page 19 for location. If any errors are encountered on either side they will be displayed on the screen. Refer to error codes in programming to understand and correct the errors. If no errors have been detected, the current software version will be displayed on the screen.

## PROGRAMMING

Press the "PROGRAM" button to enter programming mode. Press "SELECT UP" and "SELECT DOWN" to move the cursor to cycle through options. Press "ADVANCE" to change the settings the cursor is currently on. Press the "PROGRAM" button to exit programming and re-start the game.

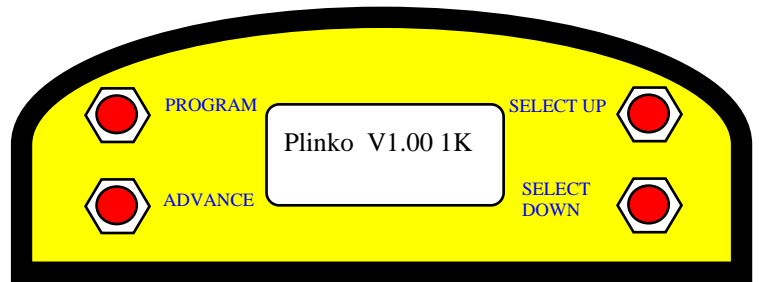
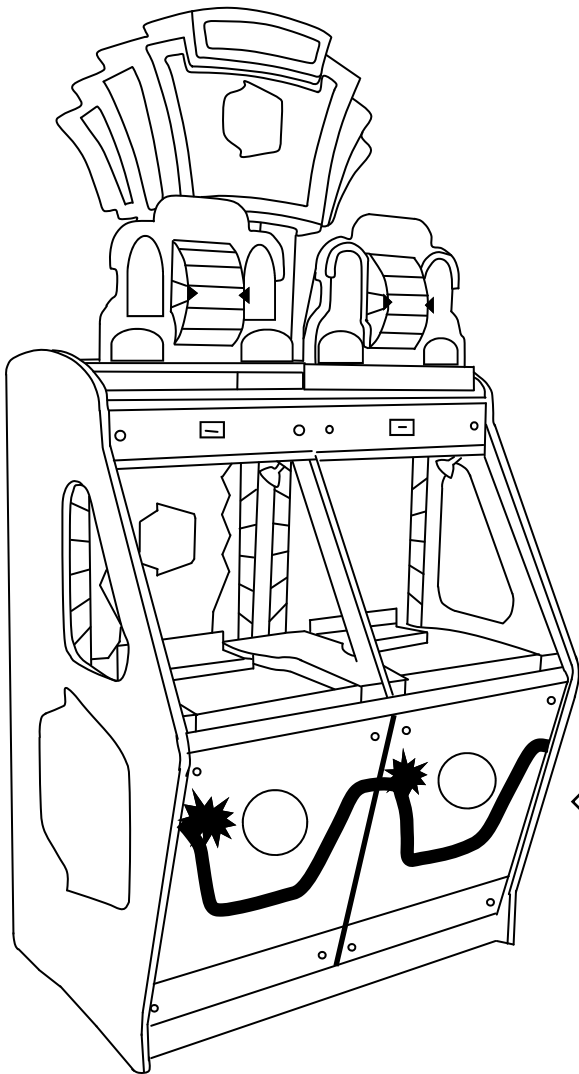

Programming console unit

Both cabinet drawers slide open to access the coin hopper, ticket dispenser, coin and ticket meters but only the left side has the programming console unit which programs both stations.

# PROGRAMMING YOUR PLINKO!

OPTION	DESCRIPTION	DEFAULT	MIN	MAX
Volume1	Game and attract Volumes	5	0	7
Volume2	Music Volume only	5	0	7
Cylon	If set to 1 red LED must be lit to light letter	0	0	1
JFP (Mercy)	Tickets given when coin goes in or just for playing	1	0	2
Over Edge	How many Tickets over the Edge	5	0	18
Feature	How many tickets to the wheel kitty	4	2	18
Power On Lights	How many letters are lit when you turn power on	0	0	3
Attract Time	When it will say come on down.	3	0	30
Coin Dispense	How many coins to dispense per swipe (This option only in the card swipe version)	1		
Factory reset	Reset factory settings	0	0	1

“**Wheel kitty**” refers to the bonus wheel’s two different bonuses. The mega bonus is the highest amount of tickets on the wheel and the bonus is all the remaining numbers. This option is divided by 2, one goes to the mega bonus and the other to remaining numbers.

For Example: Assuming your tickets are valued at a cent, setting option “JFP” to 1 (or 1 cent), setting option “Over Edge” to 5 (or 5 cents) and setting “feature” to 4 (or 4 cents) would equal total payout of 10 cents. Total 10 cents payout on 25 cent play would equal a 40 % payout.

**Cylon option defined:** The Cylon feature increases the difficulty to achieve the bonus wheel spin by limiting when the letters can be lit. When the LED moves back and fourth and a coin enters the chute for that letter, if the red LED is not correctly lit on that letter, the letter will not light.

## ERROR CODES

Error	Description		
6	L Ticket Err	Ticket dispenser empty	Fill with tickets
5	R Ticket Err	Right ticket dispenser empty\	Fill with tickets
4	Compact Flash Err	Cannot read compact flash	Replace CF
3	L Wheel Err	Cannot find home sensor	Check sensor
2	R Wheel Err	Cannot find home sensor	Check sensor
1	L Switch Board Comm Err	Cannot find cylon board	Check connection
0	R Switch Board Comm Err	Cannot find cylon board	Check connection

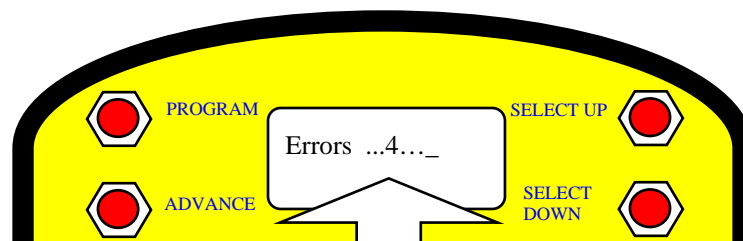

Errors will be displayed whenever they are encountered. A dot is shown when no errors are detected. The dot is replaced by the error number encountered. Multiple errors can be shown at the same time on the display. A display of ...45.. means that there is no response from the flash card and the right station is out of tickets.

# SETUP - PLAYFIELD

It is recommended that you load at least 500 tokens onto the playfield (without any dropping into the hopper) in each station once you have located the final placement of this game. Begin by unlocking both locks and removing the coin chute assembly, you must unplug the coin sensor harness to completely remove the assembly, and put this aside. Remove the front glass and place aside. Insert coins into the two rows of risers as shown in figure 1. Make sure the coins are tightly packed from end to end. With the game powered on, drop handfuls of coins above the Plinko switches but behind the plastic shield. See figure 2. This will allow the coins to naturally build up onto the playfield simulating many plays by players in a very short amount of time.

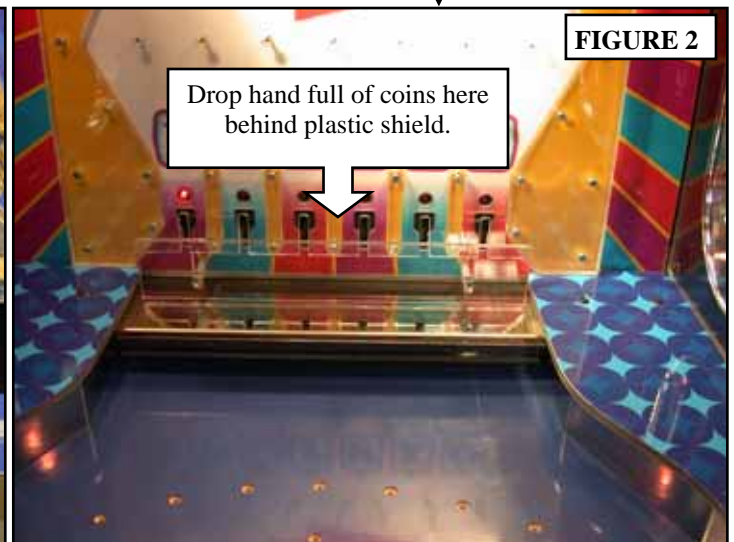
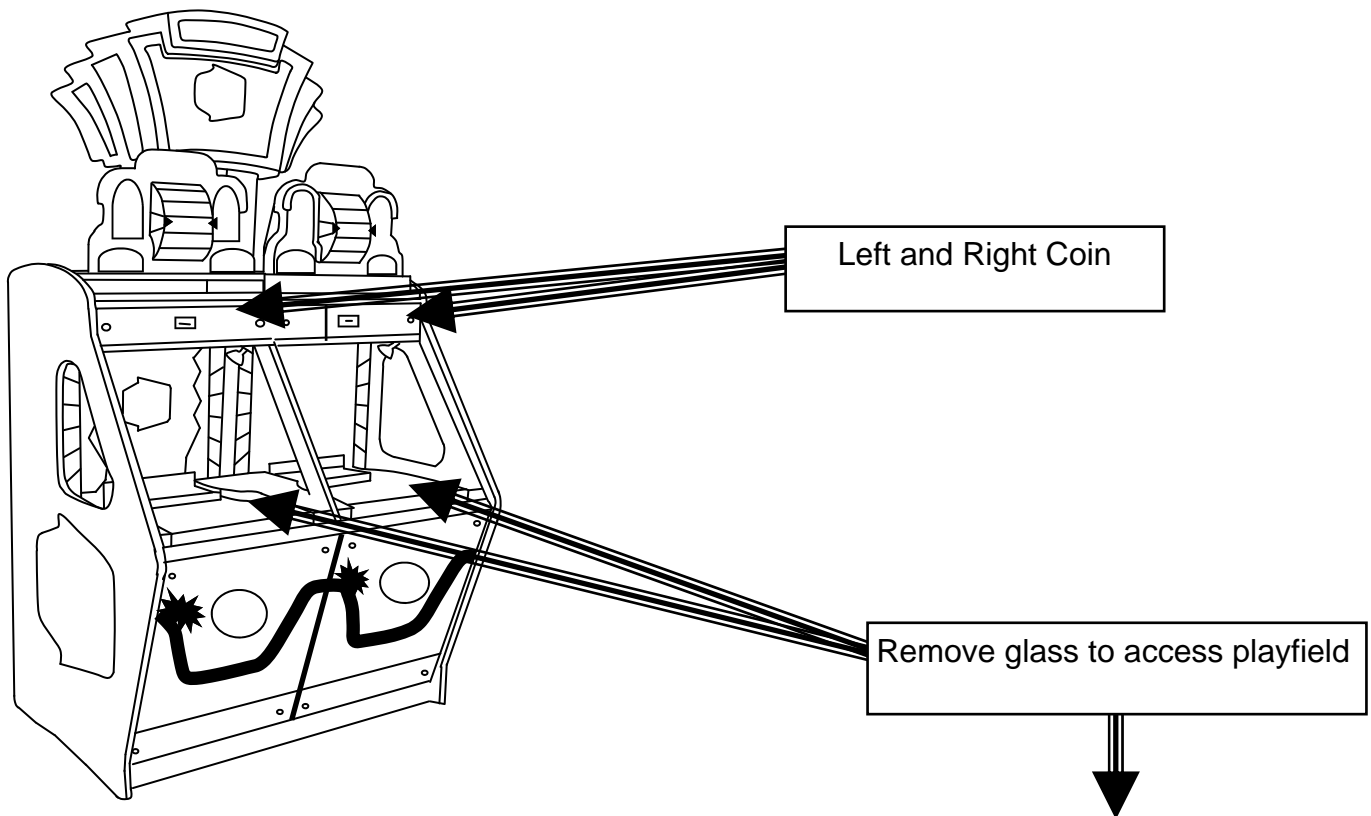

# TROUBLESHOOTING

## Security Tilt Bob & Slam Switches

This game employs two different security features to prevent players from collecting extra tickets. If the player slams the ticket drawer in an attempt to force coins to fall off the edge, the game will sound an alarm and end any current game in progress on that station. If the player rocks the entire cabinet a tilt Bob will trigger and it will immediately void any game in progress on both stations. The alarm will sound for a period of time in both occurrences.

The tilt Bob is accessed through the back of the game. The anti slam switches are located in the ticket access drawers. See diagrams below.

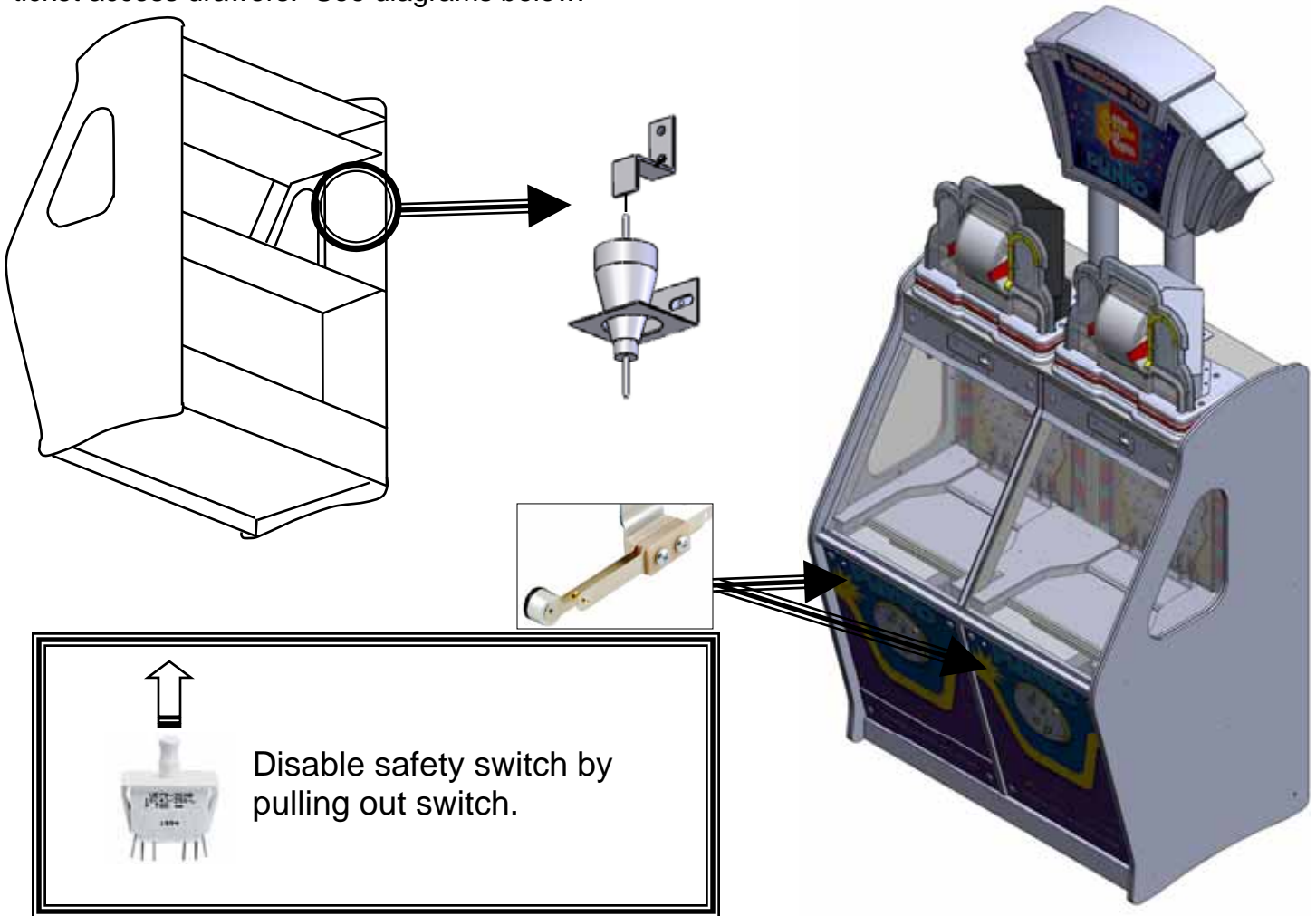

## AC Service switch

This game using a AC cutoff switch located in the back. When servicing the game if you remove the back cabinet panels with the power on, the deck pusher will stop. This is normal. If service is required with AC applied, pull the AC switch out which will allow power to the deck pushers. There one for each cabinet side.

**\*\*\* WARNING \*\*\* This ac cut off switch is for your safety as serious injury could result if disabled.**

**\*\*\* ATTENTION \*\*\* Cette ac couper commutateur est pour votre sécurité aussi grave peut en résulter des blessures si handicapés.**

# TROUBLESHOOTING

## Troubleshooting

### CAUTION

This game uses complex electronic components that are very sensitive to static electricity. Observe precautions below before handling these electronics. Failure to do so may void the warranty and damage electronic assemblies.

Before servicing electronics, turn off AC power to the game. Wait for capacitors to discharge.

DO NOT remove any of the components on the main board (e.g. compact flash and eproms) while the game is powered on. This may cause permanent damage to the parts and the main board.

Before touching or handling electronic assemblies, discharge static electricity on your body. To discharge this static, begin by connecting the line cord to a grounded outlet. Don't turn on the game. Next, touch the safety ground stud of the power supply chassis.

Store electronic assemblies in an anti-static area. Use anti-static bags to store or transport the game circuit boards.

Don't remove or connect electronic assemblies when cabinet power is on. Otherwise, you'll damage electronic assemblies and void the game's warranty.

After you complete maintenance or service, replace ground wires, shields, safety covers and install and tighten ground and mounting screw.

## Fuses - Main Power Supply

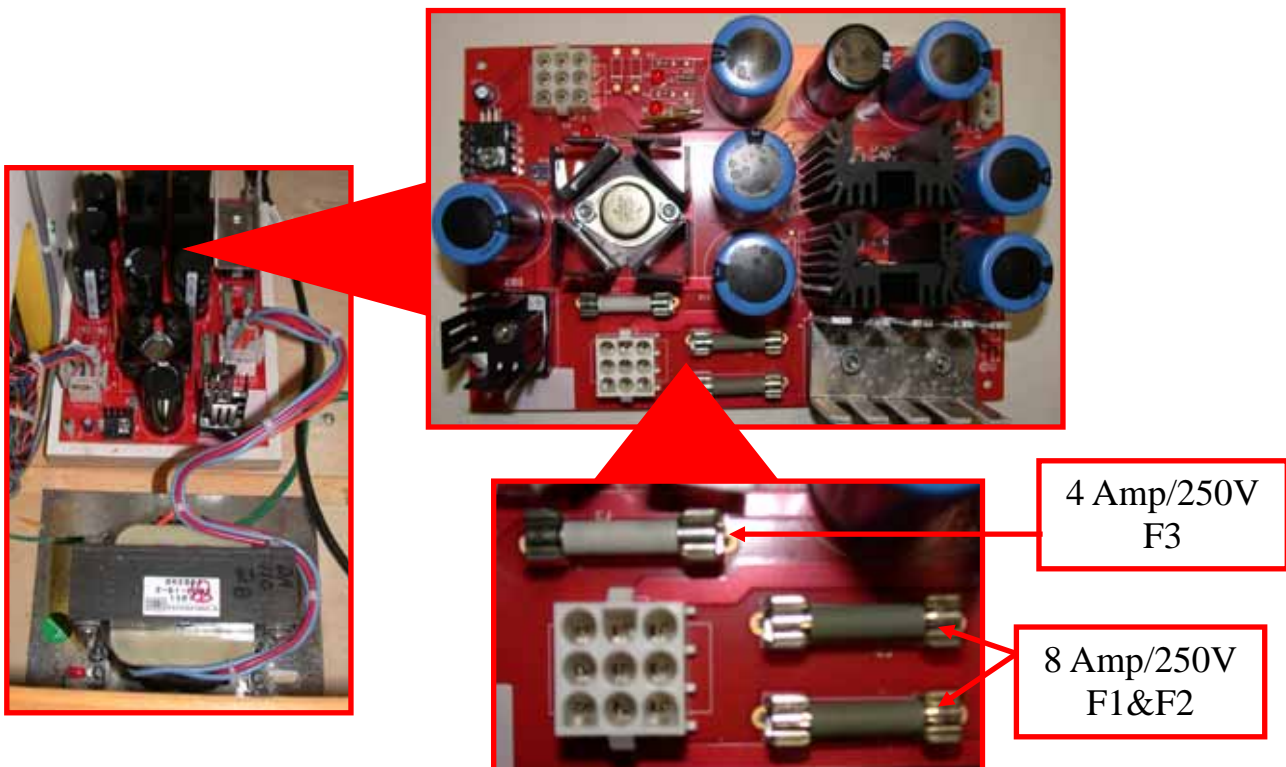

# ASSEMBLIES AND DIAGRAMS - PE1000X

ITEM NO.	PART NUMBER	DESCRIPTION	QTY.	ITEM NO.	PART NUMBER	DESCRIPTION	QTY.
1	PE3150CX	PUSHER CABINET	1	33	PE1194X	ORIENTAL MOTOR ASSEMBLY	1
2	PE1018	KICK PLATE TRIM	1	34	PE1035X	COIN EDGE MTG. BRACKET	2
3	PE7107	DECAL-DIVIDER-LEFT	2	35	PE3220X	SHARK OPTP ASSEMBLY	1
4	PE7108	DECAL-DIVIDER-CENTER	1	36	DA2001X	PCBA (POWER SUPPLY)	1
5	PE3057X	FRONT PANEL ASSEMBLY	2	37	PE2034	PCBA (MAIN I/O)	1
6	SX2007X	ASY (POWER MODULE)	1	38	DA2002X	ASY TRANSFORMER 2-51-0333	2
7	PE3076X	PUSHER ASSEMBLY	1	39	MA1019	TRANSFORMER MTG PLATE	2
8	PE3068	PLAYFIELD SIDE SPACER NARROW .750	2	40	PC60628	6-32X1 3/4 PRHMS	12
9	PE3072	PLAYFIELD MIDDLE SPACER NARROW .750	1	41	PC60643	6-32 x 1/4 HH SPACER 14HTSP007	28
10	PE1020	PLAYFIELD SIDE A	2	42	MS2364X	FAN ASSEMBLY	1
11	PE1009X	CASH BOX ASSEMBLY	2	43	E02027G	FAN FINGER GUARD	2
12	PE1070	ANGLED LOCK PLATE	7	44	AM-M4-N		4
13	PE1028	GLASS TRIM LOWER	1	45	6031	#8 FLAT WASHER (ZINC)	12
14	PE1021	PLAYFIELD SIDE B	2	46	6004	CR-PHMS, #8-32 x 1/2" LG.	14
15	PE3028	FRONT GLASS	2	47	6493	8-32 X 25/64 THREADED INSERT	14
16	PE3027	SIDE GLASS	2	48	6109	6-32 x 1-1/4" LG. PPHMS	2
17	PE1060	TOP WIPER CHANNEL	1	49	6023	6-32 X 2.5" SRHMS	4
18	PE1061	UPPER WIPER CHANNEL CLAMP	4	50	6158	#6 FLAT WASHER	4
19	PE1013	COIN FUNNEL	2	51	6002A	6-32 NYLOCK NUT	5
20	#8	SQ. DRIVE WOOD SCREW	1	52	PreviewCfg	#8 FLAT WASHER (ZINC)	4
21	PE1071	ARCHED LOCK PLATE	4	53	655	#8 x 3/4 SQ. DRIVE (BLACK)	30
22	655S	#8 x 5/8 SQ. DRIVE (SILVER)	84	54	6466	1/4-20 X 2 FHMS	14
23	PE1006X	COIN CHUTE ASSEMBLY	2	55	6212	1/4 x 3/4 FLAT WASHER BLACK	4
24	PE1026X	HALOGEN BRACKET	4	56	6213	1/4-20 x 1-1/2" LG. BSHCS (BLACK, SEC.)	4
25	CR100110	BULB HALOGEN (12V/20W 36/38 DEG) (VC0157)	4	57	PE1050	14" DRAWER SLIDE	4
26	WS2039PEX	Shark Opto - PE VERSION	1				
27	PE1016	DOOR BRACKET	2				
28	PE3209	UPPER WIPER	2				
29	CP1051	TILT SENSOR	1				
30	WC1041	BRACKET (DOOR SWITCH/POD LATCH)	1				
31	2970	SWITCH (PUSH/PULL) CHERY E6930AO	1				
32	PE3052X	REAR DOOR ASSEMBLY	1				

# ASSEMBLIES AND DIAGRAMS

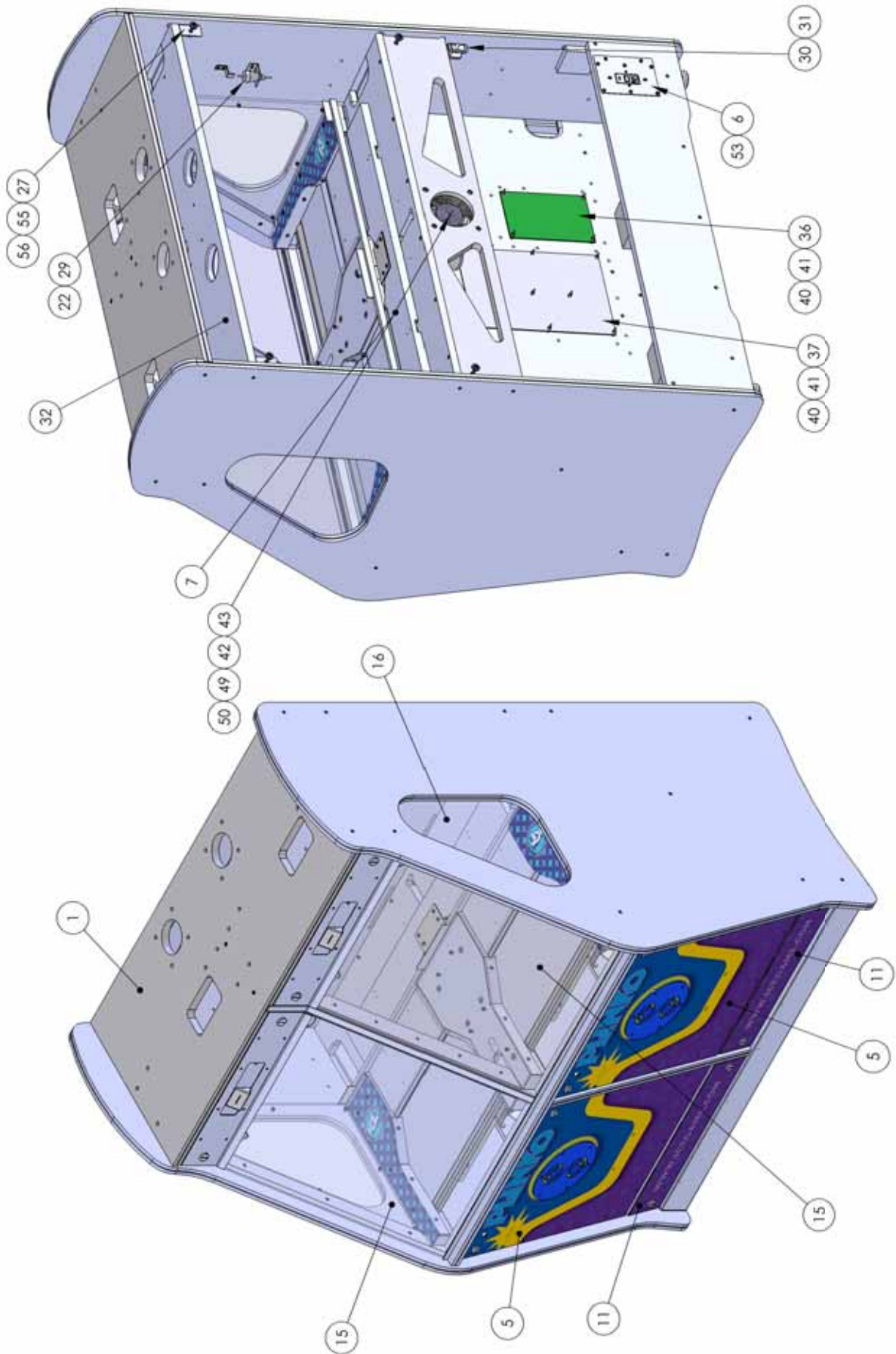

# ASSEMBLIES AND DIAGRAMS - PE3110X

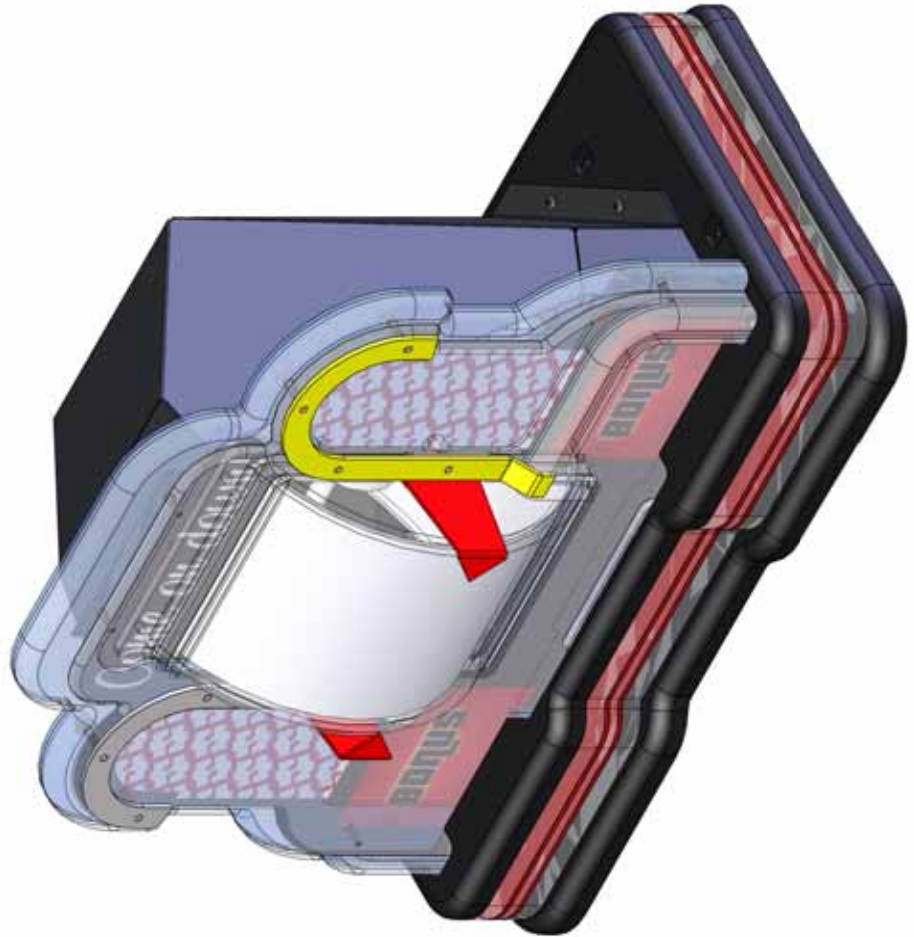

ITEM NO.	PART NUMBER	DESCRIPTION	QTY.
1	PE3110	PRIZE WHEEL BASE	1
2	PE2008X	WHEEL MECH	1
3	PE3112	BONUS FRAME	1
4	PE1110	PRIZE WHEEL HOUSING	1
5	PE3120	WHEEL GLASS	1
6	PE1140	FRONT TRIM L	1
7	PE1141	FRONT TRIM R	1
8	PE1111	BONUS LED BRACKET	2
9	655	#8 x 3/4 SQ. DRIVE (BLACK)	6
10	6061	#8-32 CABINET INSERT	4
11	PE3113	PRIZE WHEEL FRONT TRIM	1
12	PE3115	PRIZE WHEEL FRONT	1
13	PE3123	PRIZE WHEEL LOWER BASE	1
14	PE3124	PRIZE WHEEL BASE LIGHT	2
15	PE3125	PRIZE WHEEL BASE COLOR	2
16	PE3126	PRIZE WHEEL BASE CLEAR	1
17	PE1118	POINTER	2
18	PE3119	PRIZE WHEEL FRONT MIRROR	1
19	PE3135	BONUS FRAME MIRROR	1
20	6072	8-32 NYLOCK NUT	4
21	6687	#6-19 X 1/2" LG. PHILIPS PAN HEAD PLASTITE SCREW	4
22	6279	8-32 ACORN NUT (ZINC)	4
23	6489	8-32 INSERT (FLUSH) 90267A563	2
24	6177	#8-32 x 1" LG PPHMS	2
25	6131	#10 SAE FLAT WASHER	2
26	6690	#6-19 X 5/8" LG. PHILIPS PAN HEAD PLASTITE SCREW	4
27	6088	1/4-20 x 3 HH BOLT (F-T)	4
28	PC60614	025-20 KEP NUT	4
29	6250	BHCS #8-32 x 7.5" LG. (BLACK)	4
30	6004a	8-32 KEP NUT	4
31	6031	#8 FLAT WASHER (ZINC)	4
32	PE7113	DECAL-WHEEL SURROUND	1
33	PE1088	LED BRACKET - "COME ON DOWN!"	1
34	E00442PEX	15 LED RIGID	1

# ASSEMBLIES AND DIAGRAMS - PE3110X

NOTE: Adjust screw 24 to level wheel mech.

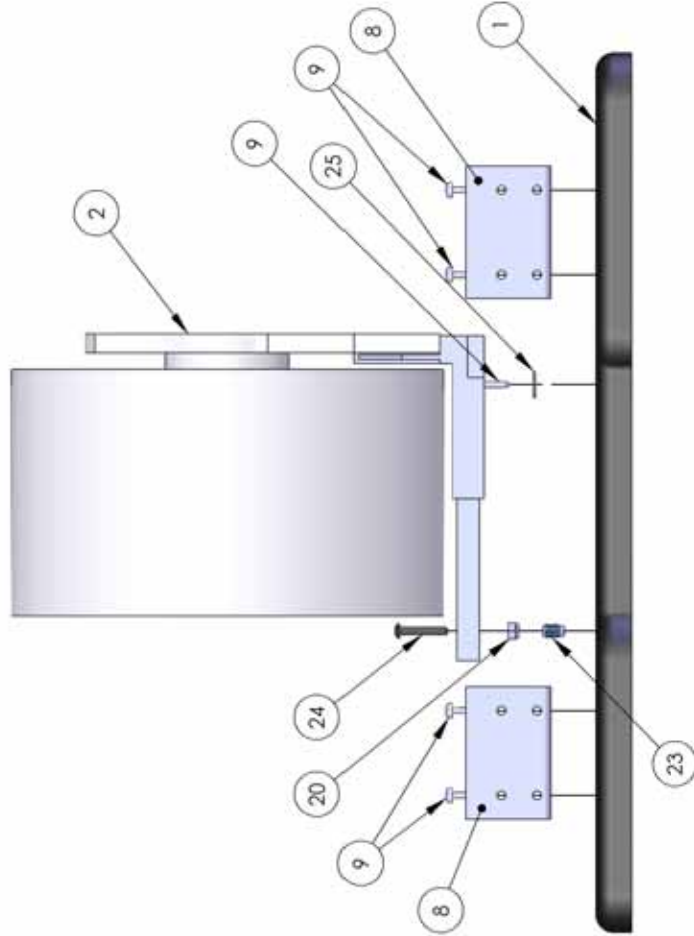

NOTE: THIS DRAWING SHOWS THE COMPONENTS USED TO CREATE THE LEVELING MECHANISM FOR THE WHEEL ASSEMBLY.

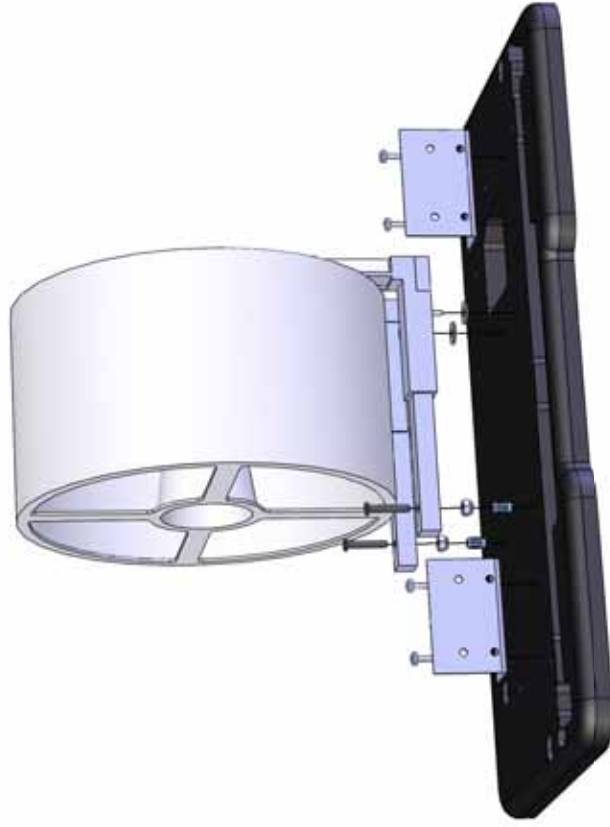



# 1006X Coin Chute Assembly

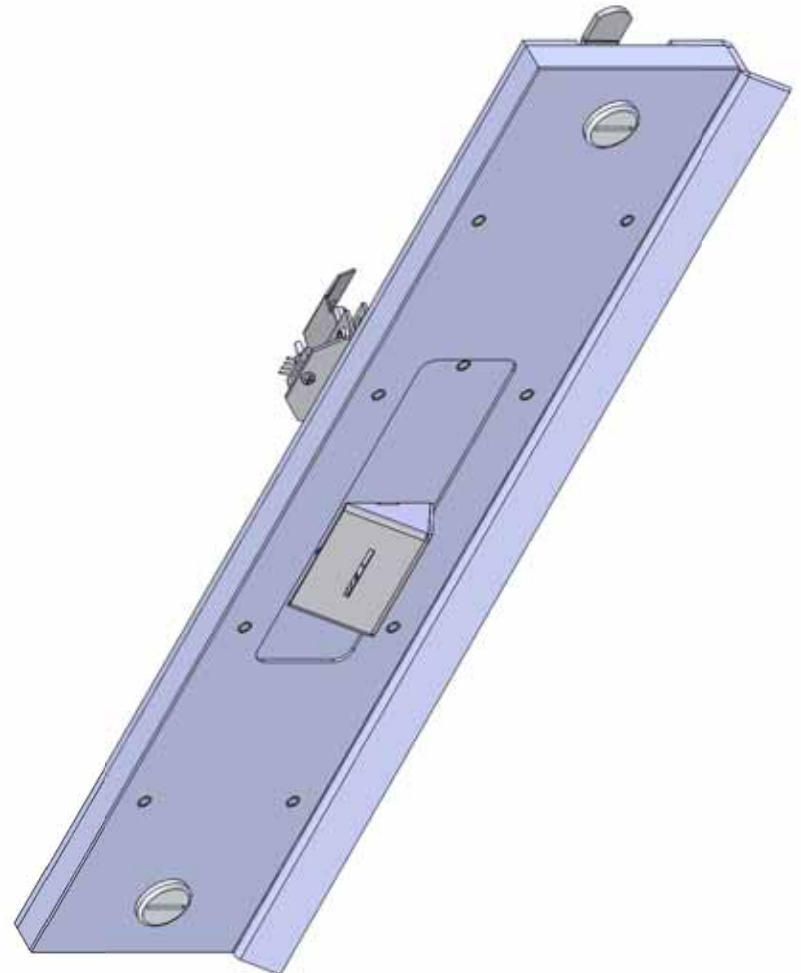

ITEM NO.	PART NUMBER	DESCRIPTION	QTY.
1	PE3078	COIN CHUTE BACK	1
2	PE1010	COIN CHUTE SLIDE PLATE	1
3	PE1006	COIN CHUTE FRONT PANEL	1
4	PE3006	COIN CHUTE SHUTTLE	1
5	PE1011	COIN CHUTE GUIDE RAIL	1
6	PE1012	REJECT COIN TRAY	1
7	6004a	8-32 KEP NUT	3
8	6691	M4 x 10 PPHMS	2
9	4002	BUMPER (#2953w) 9540K53	2
10	655	#8 x 3/4 SQ. DRIVE (BLACK)	2
11	6073	6-32 X 3/4 PPHMS	3
12	6060	4-40 X 3/4 PPHMS	1
13	PE1029	COIN CHUTE GLASS TRIM	1
14	6072	8-32 NYLOCK NUT	8
15	6086	HJNUT 8-32	1
16	E00436PEX	ASY (COIN IN SENSOR)	1
17	PE1081	COIN SENSOR BRACKET CLAMP	1
18	Coin Chute (see sales order)	COIN CHUTE	1
19	5014	7/8" CAMLOCK	2
20	PE1080	COIN CHUTE SENSOR BRACKET	1
21	6489	8-32 INSERT (FLUSH) 90267A563	1

# PE1006X Coin Chute Assembly

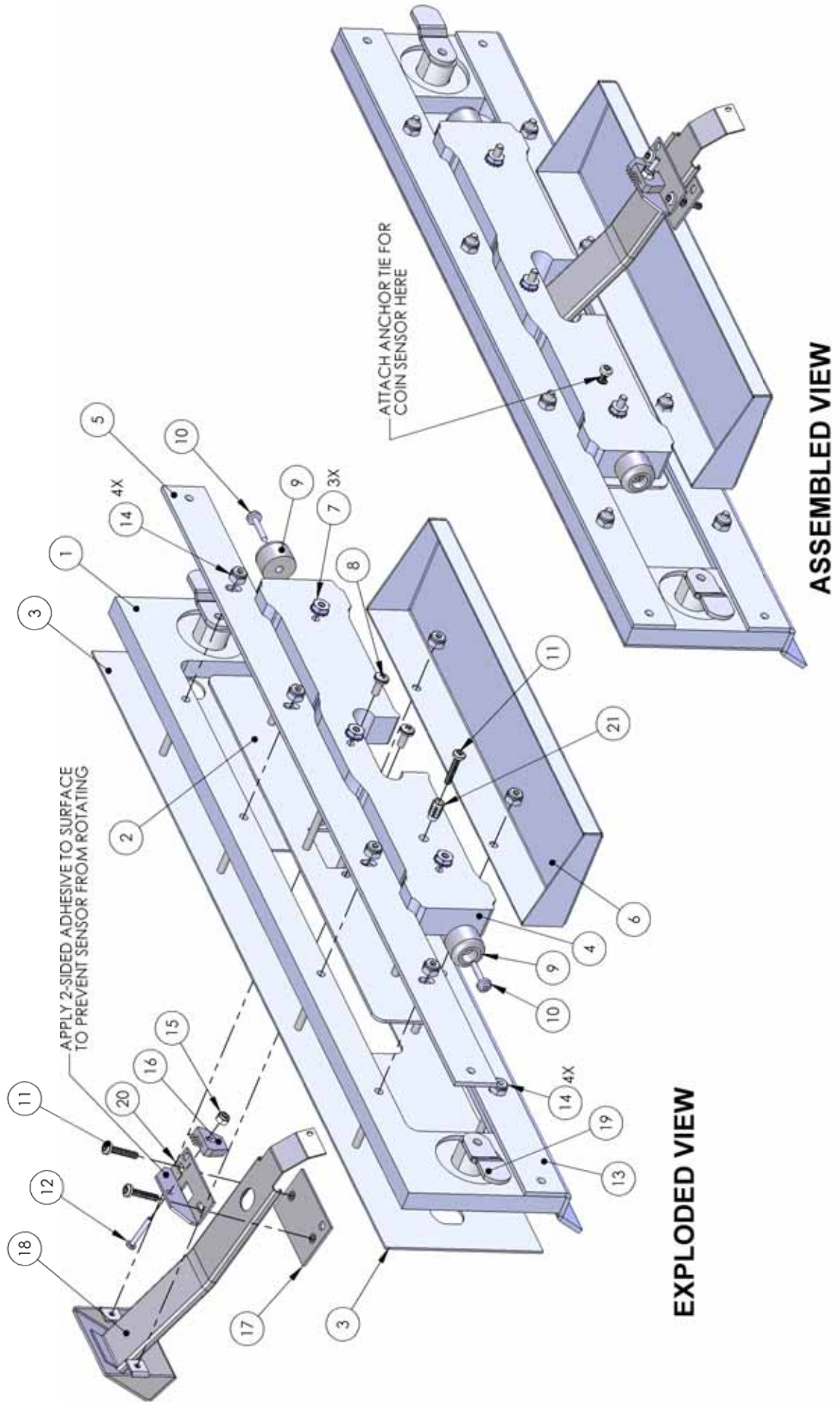

# ASSEMBLIES AND DIAGRAMS - PE3057X

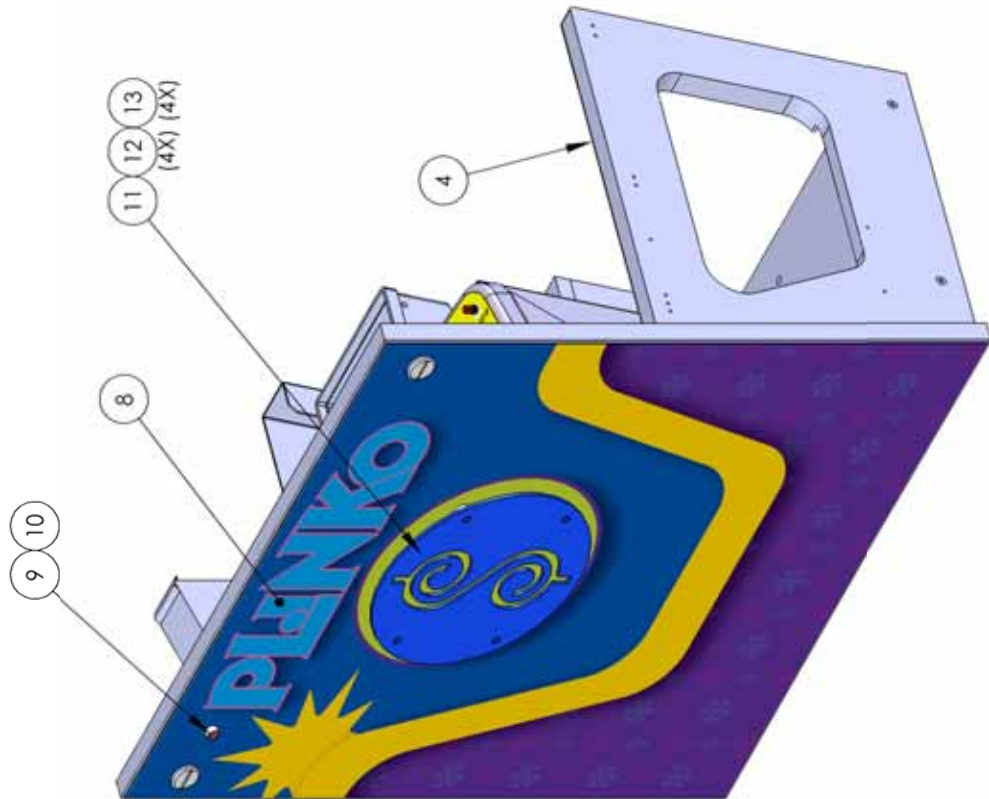

ITEM NO.	PART NUMBER	DESCRIPTION	QTY.
1	CR070113	HOPPER CUBE MKII .870-.937	1
2	1024	TICKET BIN (DOUBLE)	1
3	HH5005D	TICKET DISPENSER (DELTRONICS)	1
4	PE3057CX	CABINET ASSEMBLY-FRONT DOOR	1
5	AR2007	6 X 9 SPEAKER	1
6	655S	#8 x 5/8 SQ. DRIVE (SILVER)	18
7	1026	BRACKET LOW TICKET SWITCH MOUNT	1
8	PE7157	DECAL - FRONT DOOR	1
9	E01017	8212 LED HOLDER	1
10	E08212	(ROHS) LED RED FLASHING	1
11	PE1150	PLINKO SPEAKER COVER	1
12	6305	SPACER, NYLON 1/2x.260x1/4L	4
13	6040	10-24 KEP NUT	4
14	PE3011X	PROGRAMMING PANEL	1
15	6189	#4 x 1" LG. PH PAN TY AB SCREW	2
16	5014	7/8" CAMLOCK	2
17	PE1056	COIN OVERFLOW	1

# ASSEMBLIES AND DIAGRAMS - PE3057X

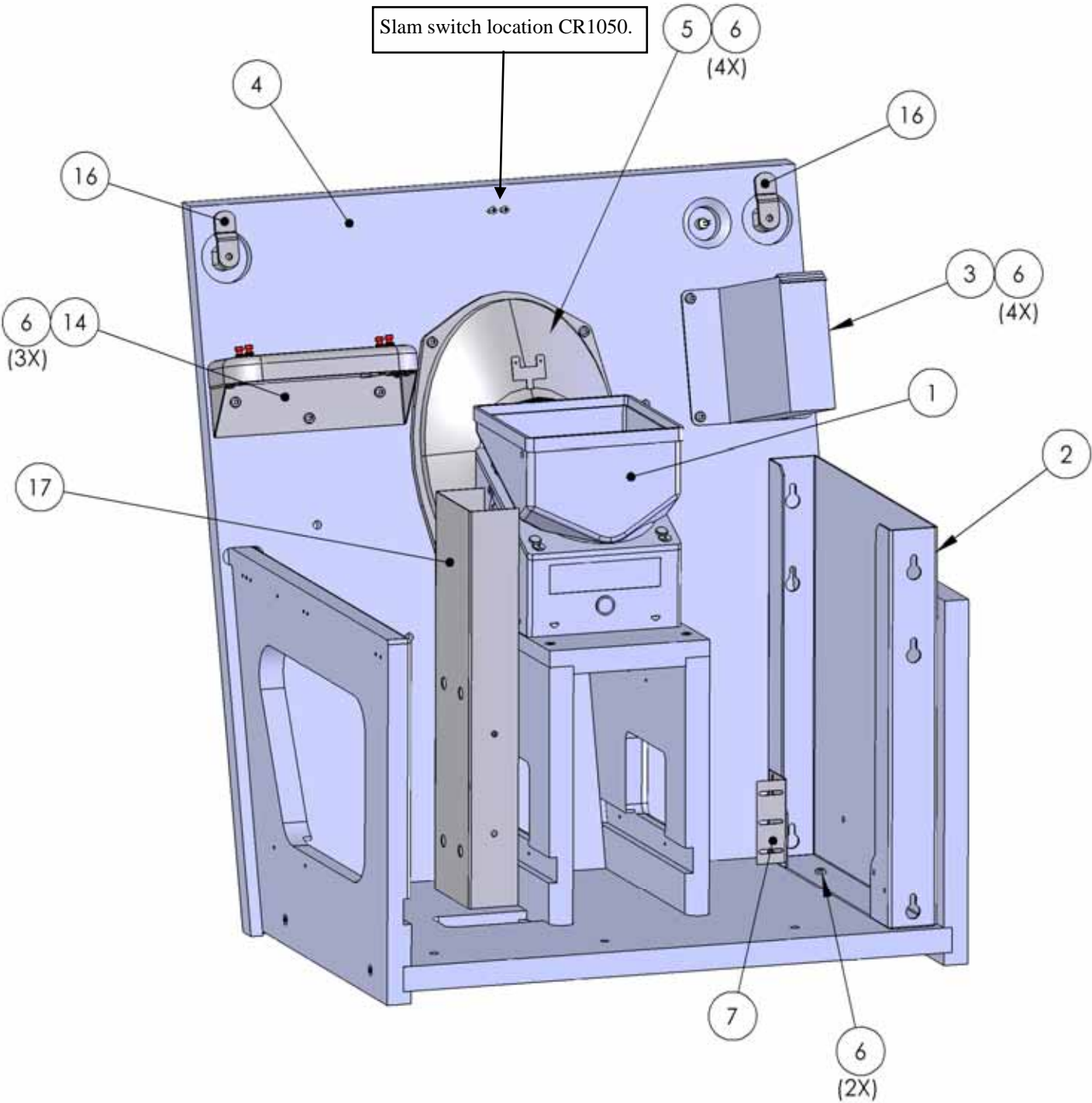

# ASSEMBLIES AND DIAGRAMS - PE3011X

ITEM NO.	PART NUMBER	DESCRIPTION	QTY.
1	2289X	ASY (RESET BUTTON)	4
2	PE3011	PROGRAMMING PANEL FACE	1
3	PE1096	PROGRAMMING PANEL BRACKET	1
4	E00433	LCD Module 16 x 2	1
5	6071	#6 x 1/2" LG. SELF-TAP (BLACK)	4
6	6294	Nylon Spacer	4
7	6199	#2 X 1/2" LG. PPHMS	4
8	PE7158	DECAL - PROGRAMMING ASSY	1
9	E00435	HEADER .100 DUAL ROW 16-PIN ST	1

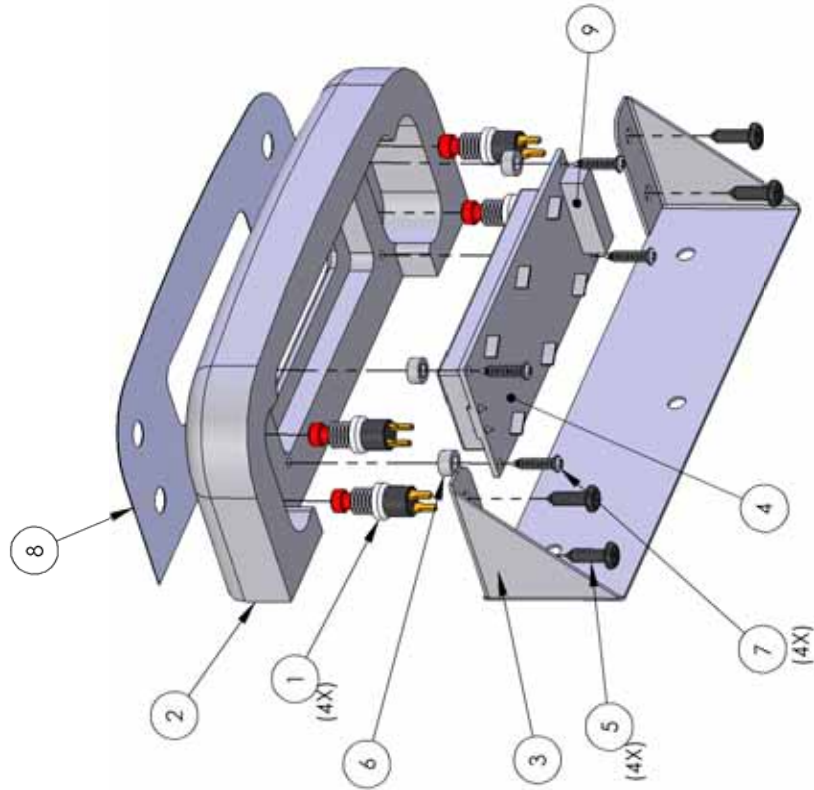

EXPLODED VIEW

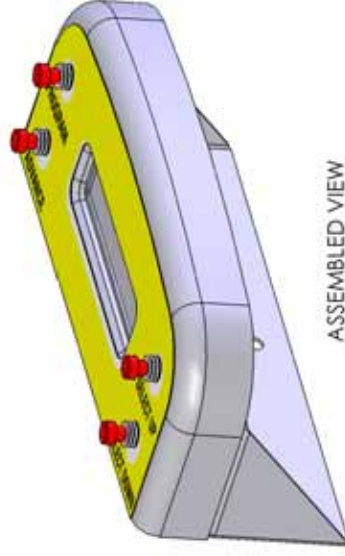

ASSEMBLED VIEW

# 1009X Coin Drawer Assembly

ITEM NO.	PART NUMBER	DESCRIPTION	QTY.
1	5014	LOCK (710-010-01B)	2
2	PE3056	CASH BOX FRONT	1
3	PE1009	CASH BOX	1
4	655	#8 x 3/4 SQ. DRIVE (BLACK)	7
5	PE7156	CASH BOX GRAPHIC	1

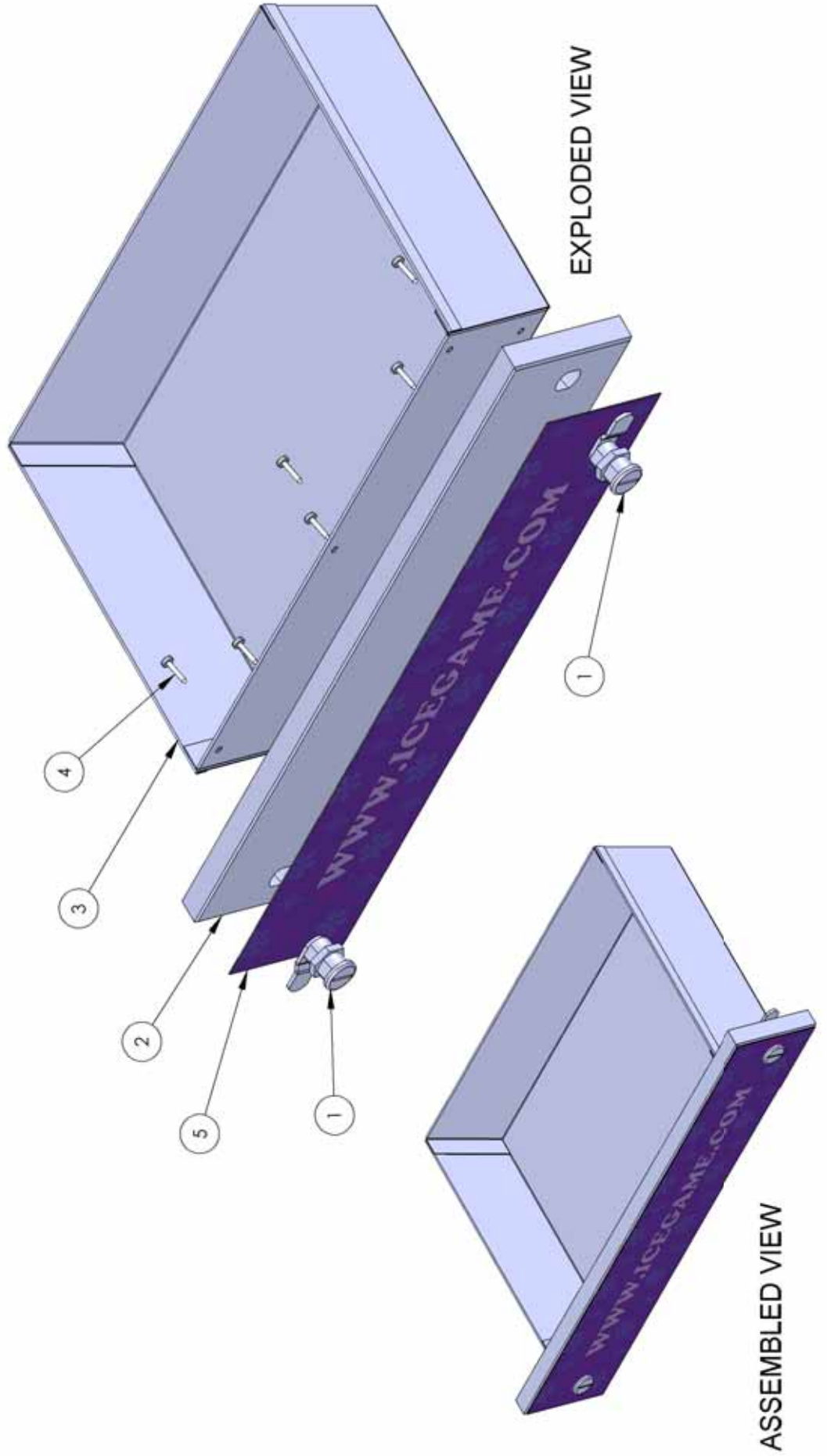

# 3130X Back Playfield Assembly



ITEM NO.	PART NUMBER	DESCRIPTION	QTY.
1	PE7130	DECAL-PLAYFIELD	1
3	PE2035X	PCBA (OPTO SWITCH)	1
4	PE3133	PLINKO DIVIDER	5
5	PE3132	PLINKO SIDE	2
6	6686	3/32 X 9/16	40
7	PE2036X	PCBA (LED DISPLAY)	1
8	PC60643	6-32 x 1/4 HH SPACER	12
9	PE3136	COIN LEVELER	1
10	6127	6-32 x 1 HH METAL SPACER	2
11	SK624	6-32 KEP NUT	25
12	656	6-32 x 3/4 PEM STUD (ROHS) (FH-632-12ZI)	22
13	6002	6-32 x 1/2" LG. PPHMS	4
14	6146	6-32X2 PRHMS	3
15	6203	FH-632-20	3
16	6158	#6 FLAT WASHER	22

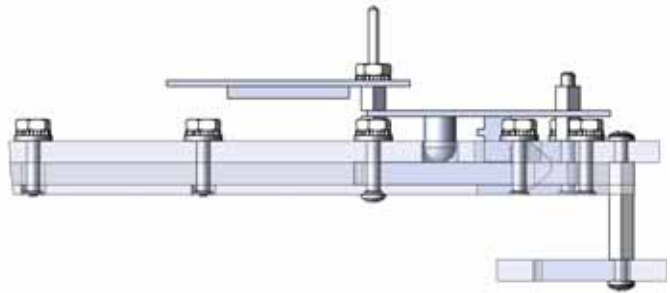
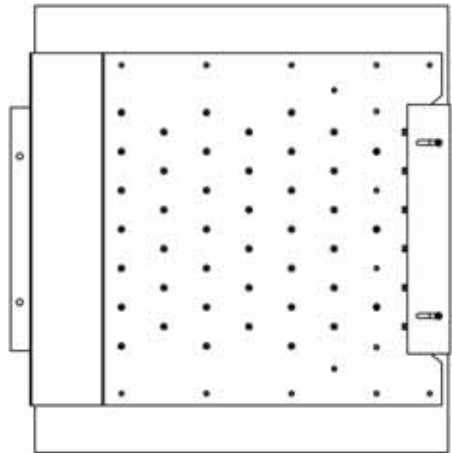
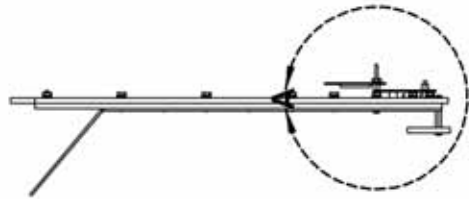
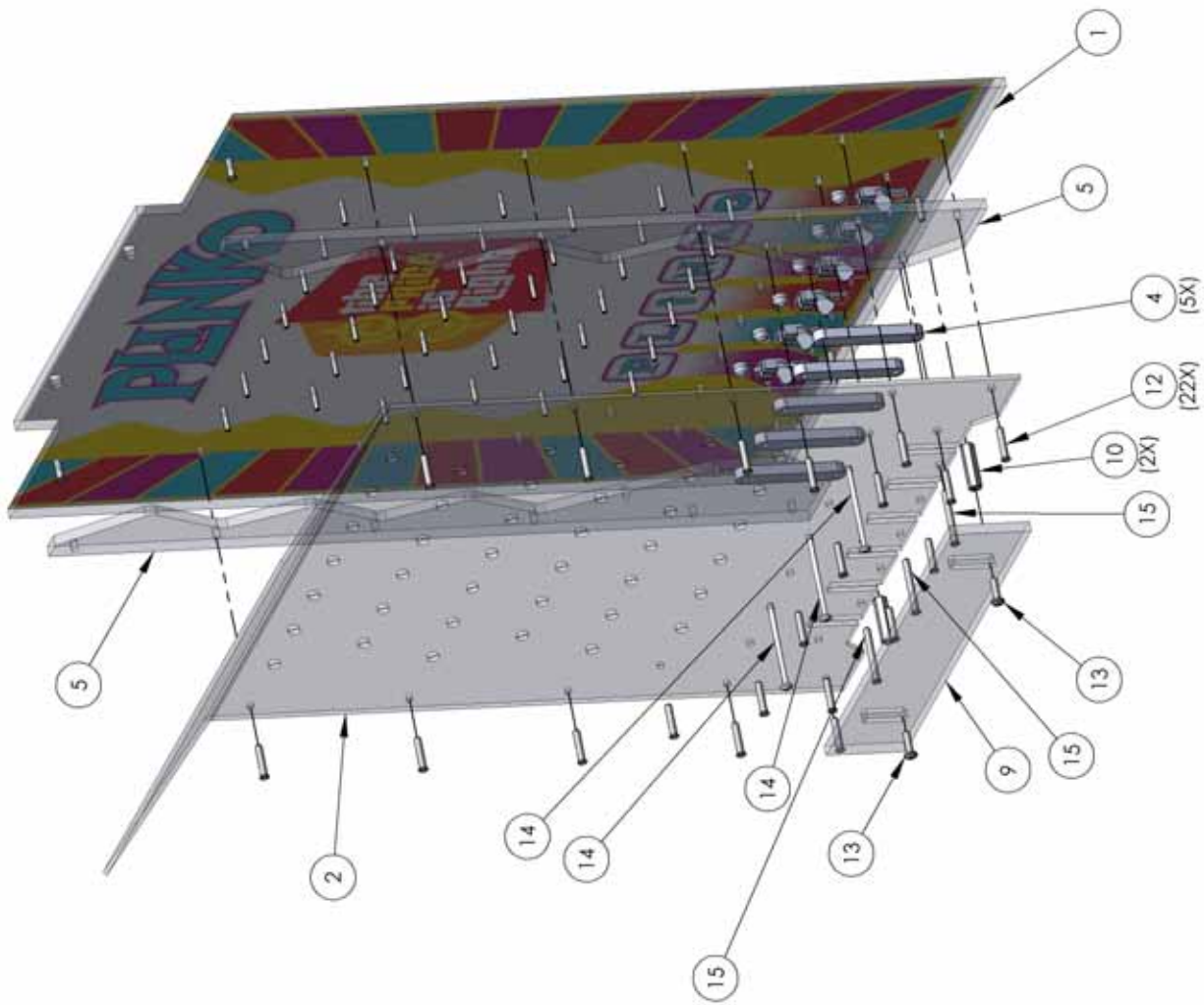

# 3130X Back Playfield Assembly

DETAIL A  
SCALE 1 : 2

# 3130X Back Playfield Assembly

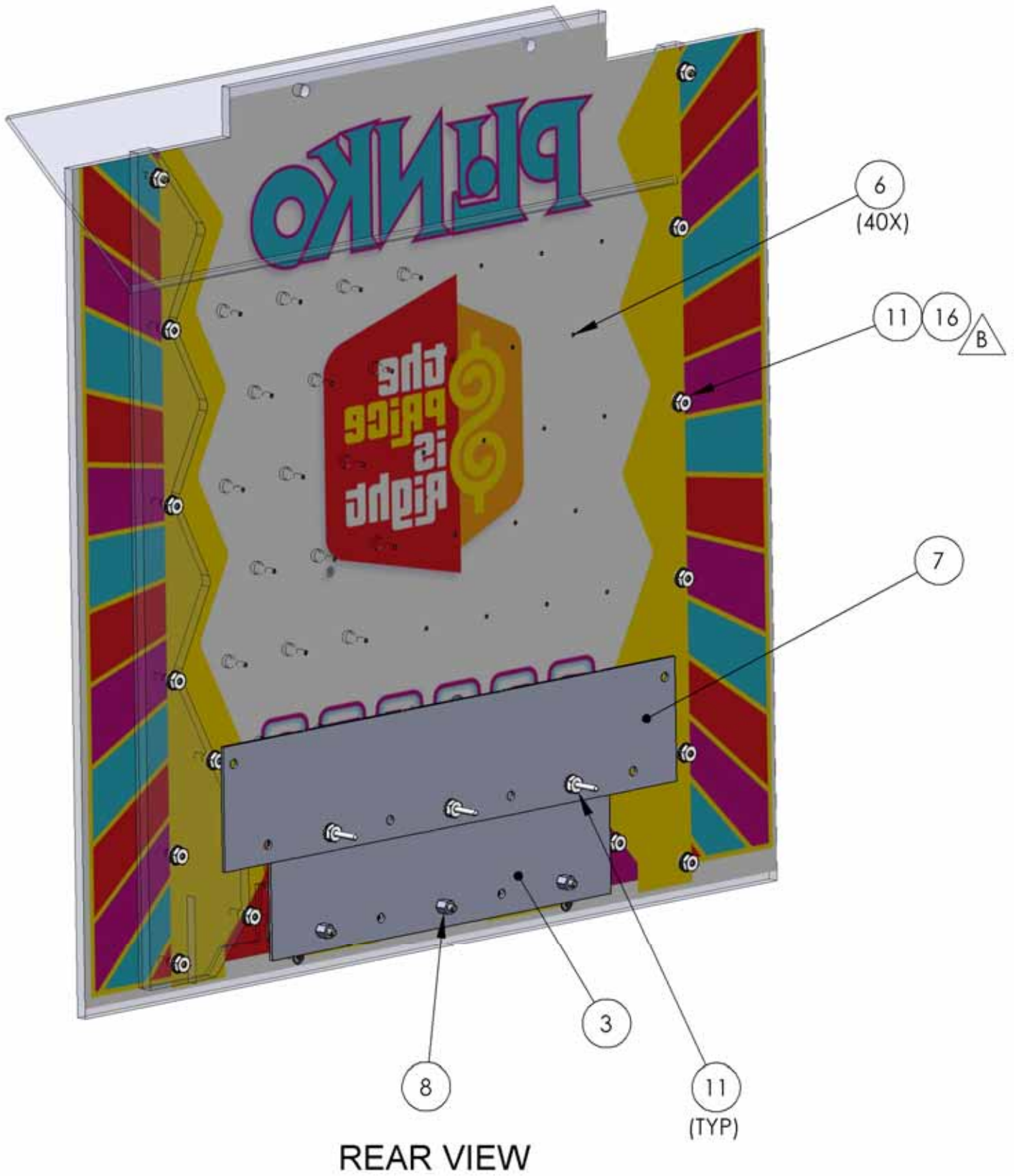

# 3076X Assembly

ITEM NO.	PART NUMBER	DESCRIPTION	QTY.
1	PE3076	PUSHER BASE	1
2	PE3008	LOWER WIPER	2
3	PE1042	PUSHER EDGE	2
4	PE1041	PUSHER DECK	2
5	6189	#4 x 1" LG. PH PAN TY AB SCREW	4
6	6442	1/4 OD x 5/16 #6 NYLON UNTHREAD ROUND SPACER	4
7	6031	#8 FLAT WASHER (ZINC)	8
8	6002A	6-32 NYLOCK NUT	8
9	CR060008S	SLIDE PUSHER DECK (SL3178) SILVER	2
10	6071	#6 x 1/2" LG. SELF-TAP (BLACK)	8
11	PE1019	PUSHER DECK CAM CHANNEL	1
12	6061	#8-32 CABINET INSERT	4
13	6004	CR-PHMS, #8-32 x 1/2" LG.	4

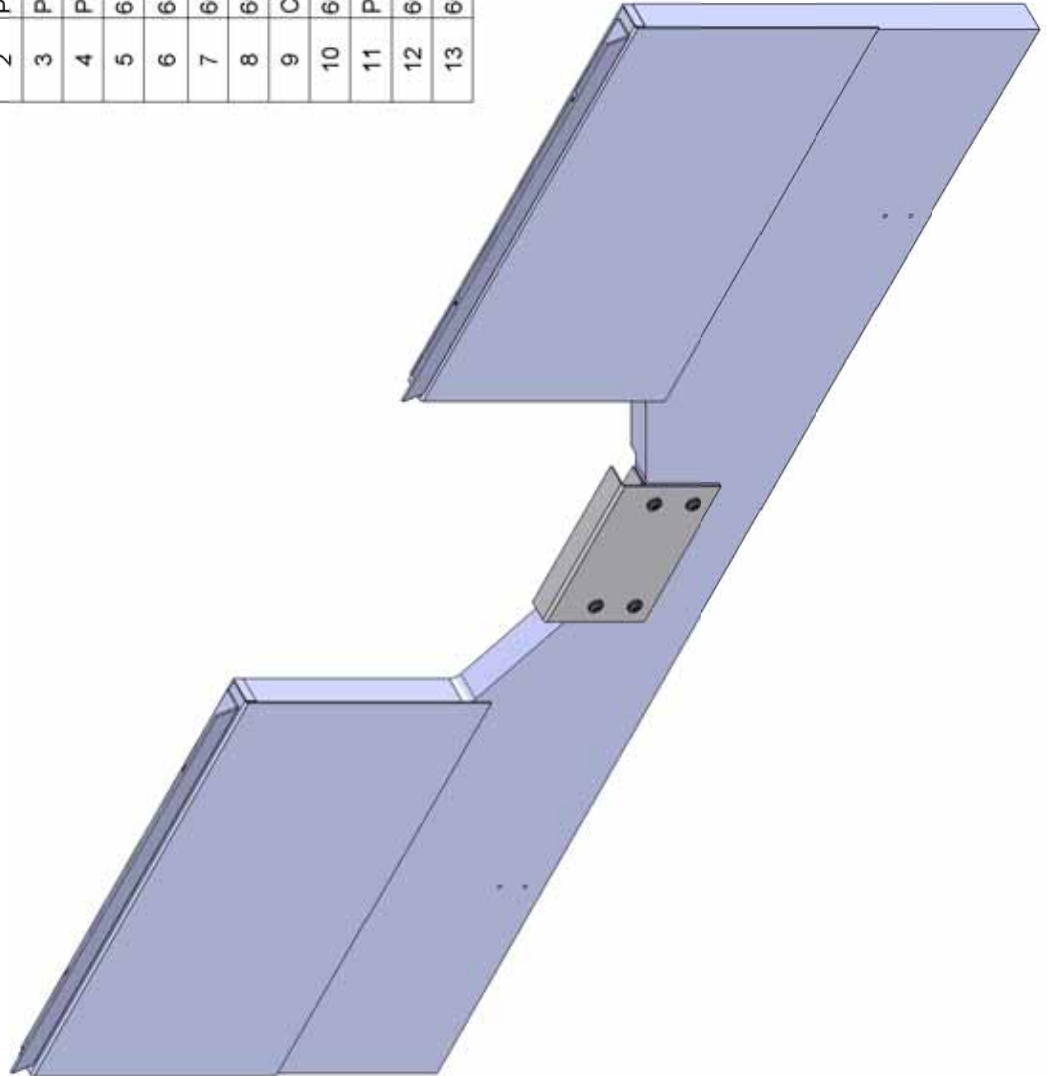

# 3076X Assembly

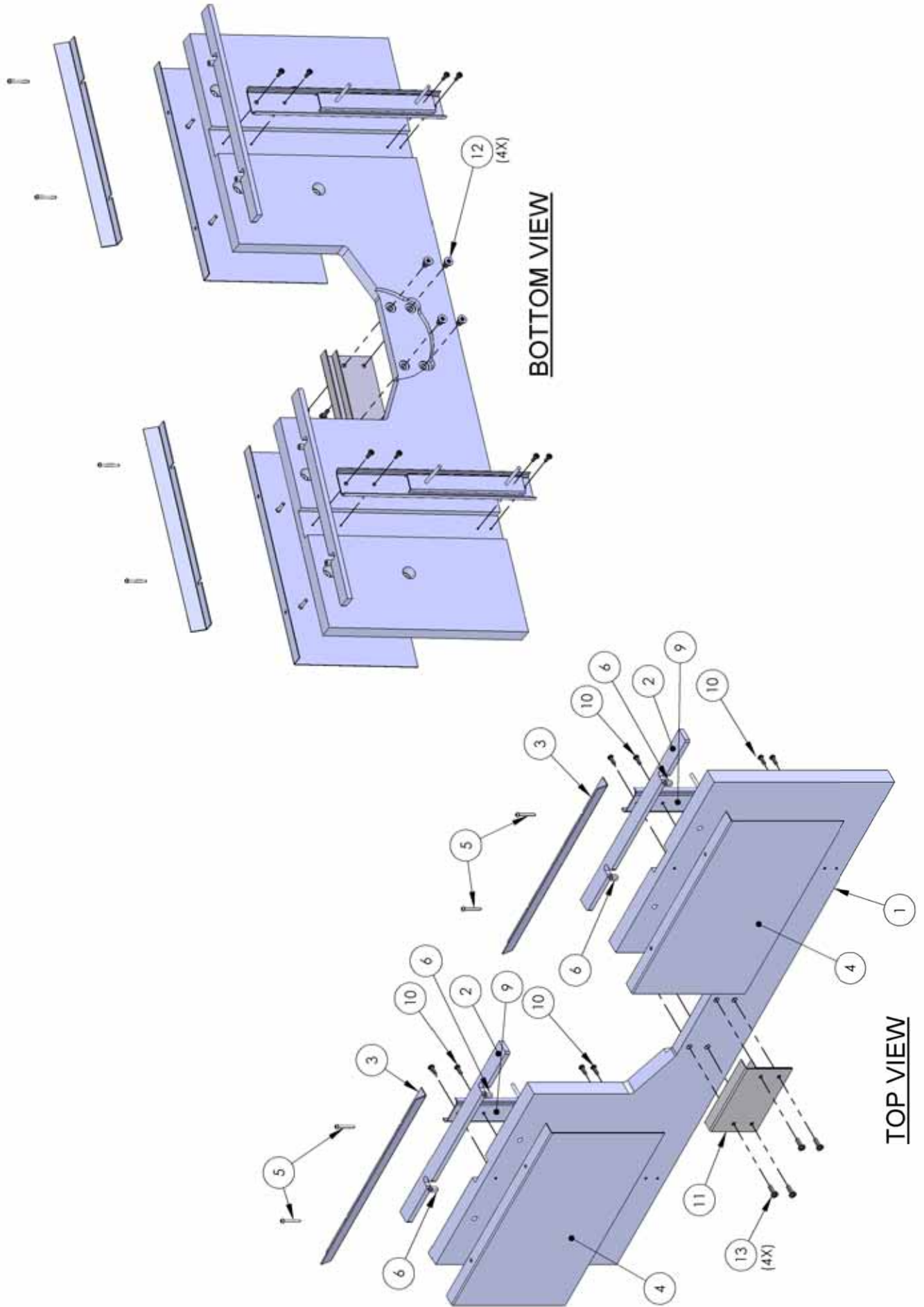

# 1100X Assembly

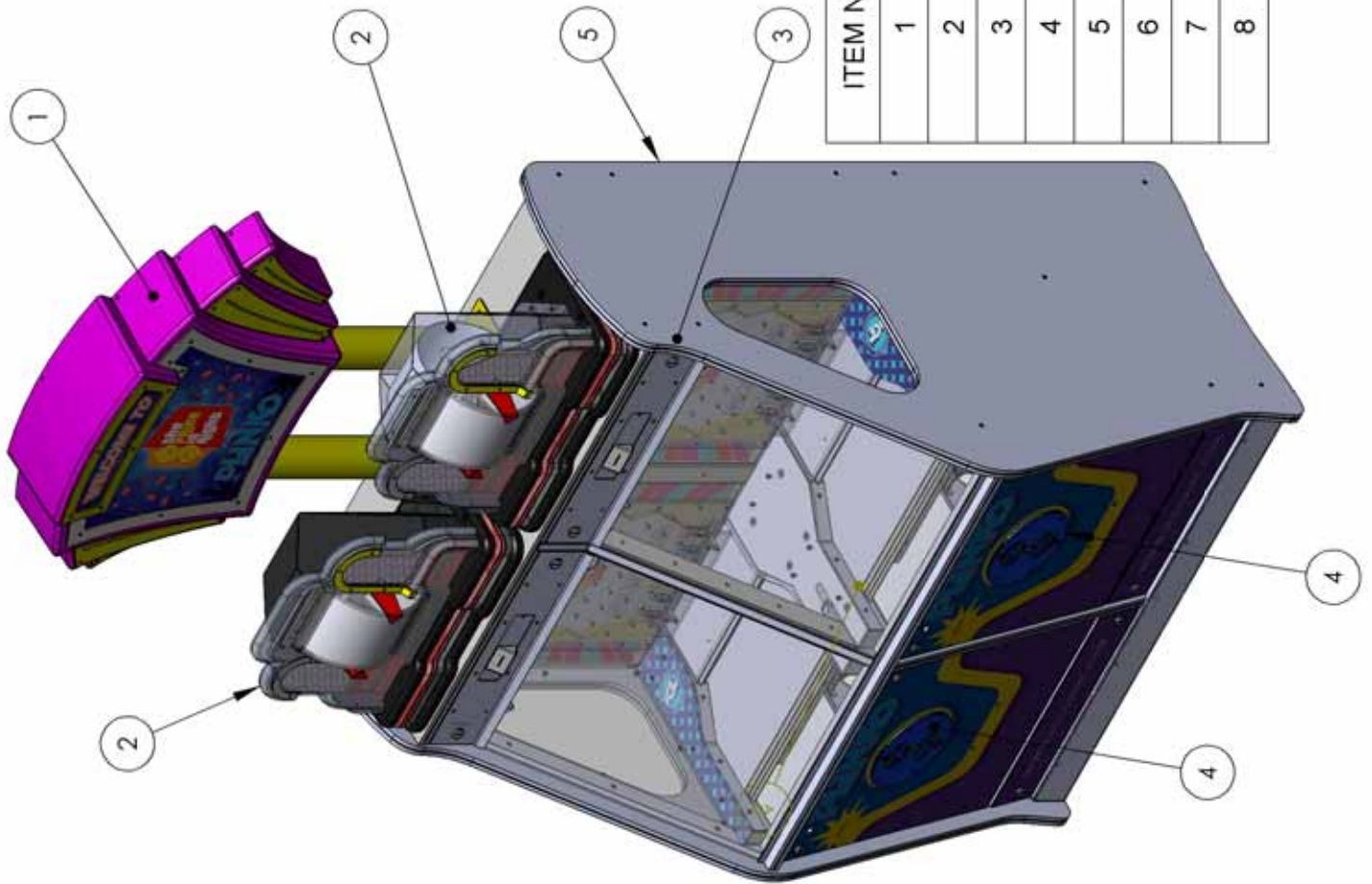

ITEM NO.	PART NUMBER	DESCRIPTION	QTY.
1	PE3127X	MARQUEE ASSEMBLY	1
2	PE3110X	PRIZE WHEEL ASSEMBLY	2
3	PE3130X	PLINKO ASSEMBLY	2
4	PE1150	PLINKO SPEAKER COVER	2
5	PE1000X	PUSHER CAB ASSEMBLY	1
6	PE3067	FRONT GLASS SUPPORT	2
7	PE1160	CENTER COVER	1
8	PE3109	CENTER DIVIDER CLIP	2



# PARTS LISTINGS

## Misc. Parts

XBFP9062359	Coin Chute .984
PE1050	Drawer Slide
PE3027	Side glass
PE3028	Front glass
1024	Ticket Bin
1026	Bracket for low ticket switch
PE3127X	Marquee 2 player
CR060008S	Slide pusher deck
SX2002AX	Assembly transformer

## Electrical Parts

CG2027	Power cord 9' 10"
CR100110	12v 20w 36/38 Halogen Bulb
CP1051	Tilt Sensor
DA2001X	Main Power Supply
DA2002X	Transformer for Main power supply
E02027G	Fan Guard
E02970	Cherry push/pull switch
MS2764X	Small fan assembly
PE2009A	Gearbox
PE2009X	Motor Assembly
PE2034X	Main I/O
AR2007	Speaker 6x9
CR070113A	Hopper Cube MKII .950 to 1"
CR1050	Anti-slam switch
E00211	Low Ticket switch
HH5005	Ticket Dispenser
2289X	Reset assembly button
E00433	LCD Module 16x2
E00411PEX	Red LED strip
E00414PEX	Blue LED strip
PE2008X	Bonus Wheel Assembly
PE2035X	Opto Switch
PE2036X	LED display
PE8520X	Socket for Halogen
SX1026-P802	Fan Coverl
SX2007X	Power module
E00436PEX	Coin in sensor

## Graphics and Decals

PE7158	Decal - Programming assembly
PE7157	Decal - Front door
PE7110	Decal - Wheel Reel
PE7113	Decal - Wheel Surround
PE7114	Decal - Wheel surround gold
PE7100	Decal - Cabinet lower side
PE7102	Decal - PC Board
PE7107	Decal - Left Divider
PE7109	Decal - Right Divider
PE7156	Decal - Cash box front drawer
PE7116	Decal - Corner Glass
PE7104	Decal - Instructions 'Cylon eye' version
PE7105	Decal - Instructions 'Standard' version

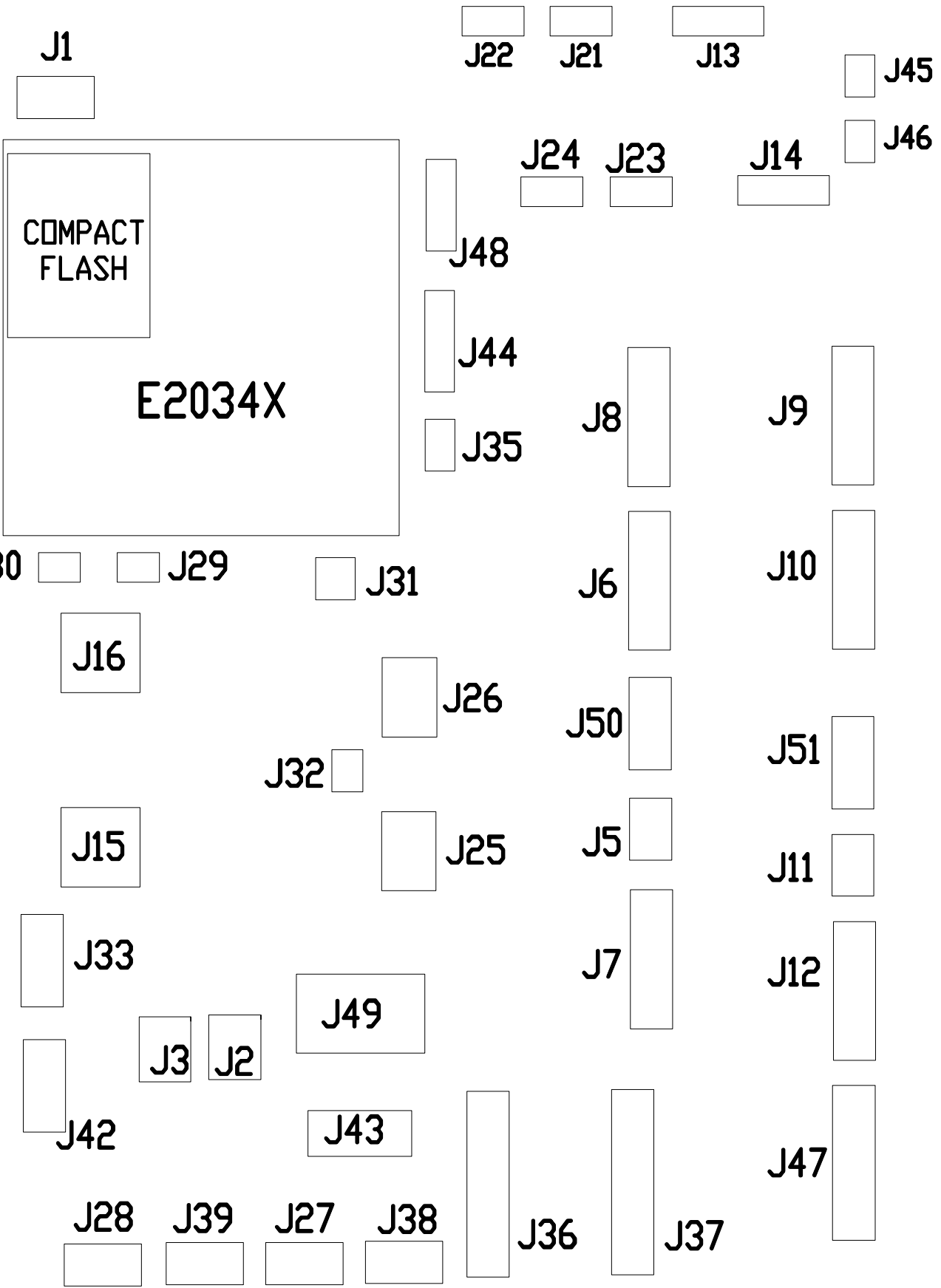



# WARRANTY POLICY

I.C.E. Inc warrants all components in new machines to be free of defects in materials and workmanship for the period listed below:

- 180 days on Main PCB's, Computers & Motors
- 1 year on all LCD monitor panels
- 90 days on all other electronic and mechanical components
- 30 days on all I.C.E. repairs and parts purchases

I.C.E. Inc shall not be obligated to furnish a warranty request under the following conditions:

- Equipment or parts have failed through normal wear and tear
- Equipment has been subjected to unwarranted stress, abuse or neglect
- Equipment has been damaged as a result of arbitrary repair/modification

Products will only be covered under warranty by obtaining an I.C.E. authorized RMA #. To obtain an RMA # please provide I.C.E. tech support with the game serial # or original I.C.E. invoice # and a detailed description of the failure or fault symptoms.

I.C.E. Inc will assume no liability whatsoever for costs associated with labor or travel time to replace defective parts. All defective warranty covered components will be replaced with new or factory refurbished components equal to OEM specifications.

I.C.E. Inc will cover domestic UPS ground, or comparable shipping costs during the warranty period. International or expedited shipments are available for an additional charge. To obtain credit defective parts must be returned to I.C.E. Inc, at the customer's expense, within 30 days. After 30 days a 15% re-stocking fee will apply to all returns.

ICE distributors are independent, privately owned and operated. In their judgment, they may sell parts and/or accessories other than those manufactured by I.C.E. Inc. We cannot be responsible for the quality, suitability or safety of any non-I.C.E. part or modification (including labor) that is performed by such a distributor.

**Innovative Concepts in Entertainment**

**10123 Main St.**

**Clarence, NY 14031**

**Phone #: (716) - 759 - 0360**

**Fax #: (716) - 759 - 0884**

**[www.icegame.com](http://www.icegame.com)**