



**BIG WIN
SUPER SPIN**

DEVELOPED AND
MANUFACTURED BY



OWNERS AND SERVICE MANUAL

INNOVATIVE CONCEPTS IN ENTERTAINMENT INC.

10123 MAIN STREET, CLARENCE, NY 14031

SERVICE: 1-716-759-0360

FAX: 1-716-759-0884

E-MAIL: service@icegame.com

WEBSITE: www.icegame.com

INNOVATIVE CONCEPTS IN ENTERTAINMENT INC. ©2008

ICEALF050 V10

TABLE OF CONTENTS

Safety	3
Setup and marquee assembly	4
Game Play - Credits and Payout percentages - Tickets	5
Pie values examples	6-7
Programming	8-9
Power supply Information	9-10
Assemblies	11-19
Pull arm assembly and diagram	20-21
Large Button assembly	22
Parts number listing	23
Warranty	24-25

SAFETY AND WARNINGS

BEFORE YOU BEGIN

WARNING: WHEN INSTALLING THIS GAME, A GROUNDED A.C. RECEPTACLE MUST BE USED. FAILURE TO DO SO COULD RESULT IN INJURY TO YOURSELF OR OTHERS. FAILURE TO USE A GROUNDED RECEPTACLE COULD ALSO CAUSE IMPROPER GAME OPERATION, OR DAMAGE TO THE ELECTRONICS.

DO NOT DEFEAT OR REMOVE THE GROUNDING PRONG ON THE POWER CORD FOR THE SAME REASON AS GIVEN ABOVE. USING AN IMPROPERLY GROUNDED GAME COULD VOID YOUR WARRANTY.

HAVE A QUALIFIED ELECTRICIAN CHECK YOUR A.C. RECEPTACLE TO BE SURE THE GROUND IS FUNCTIONING PROPERLY.

INSTALLATION

The game comes ready to play with just a few simple things to keep in mind.

1. Plug the game into the A.C. outlet and turn on power to the game. The switch for the game is located on a power module on the outside rear of the game.

THIS GAME IS DESIGNED TO DISSIPATE STATIC ELECTRICITY THROUGH THE GROUNDING PLANE OF THE GAME. IF THE A.C. GROUND DOES NOT WORK, THE GAME COULD DISCHARGE STATIC ELECTRICITY THROUGH THE GAME CIRCUITRY, WHICH COULD CAUSE DAMAGE.

2. Make sure the game is level after installation. It is necessary to make sure the game is level for safety concerns.
3. Check that the A.C. voltage rating on the back of the game matches the A.C. voltage of your location.

THE POWER SUPPLY IS NOT VOLTAGE ADJUSTABLE. TO OPERATE THE GAME AT VOLTAGES OTHER THAN THOSE IT WAS DESIGNED FOR. PLEASE CONTACT OUR SERVICE DEPARTMENT FOR VOLTAGE CONVERSION INFORMATION.

WARNING

DO NOT remove any of the components on the main board (e.g. compact flash and eproms) while the game is powered on. This may cause permanent damage to the parts and the main board. Removing any main board component part while powered on will void the warranty.

NOTE: THIS GAME IS INTENDED FOR INDOOR USE ONLY.
ON THE BACK PANEL OF THE GAME: WARNING: SHOCK HAZARD - DO NOT OPEN. REFER SERVICING TO SERVICE PERSONNEL.

SETUP - MARQUEE ASSEMBLY

Refer to the below diagram for the physical assembly of the marquee. Once all bolts are tighten, open the upper back door and connect the AC power. Your marquee is now installed.

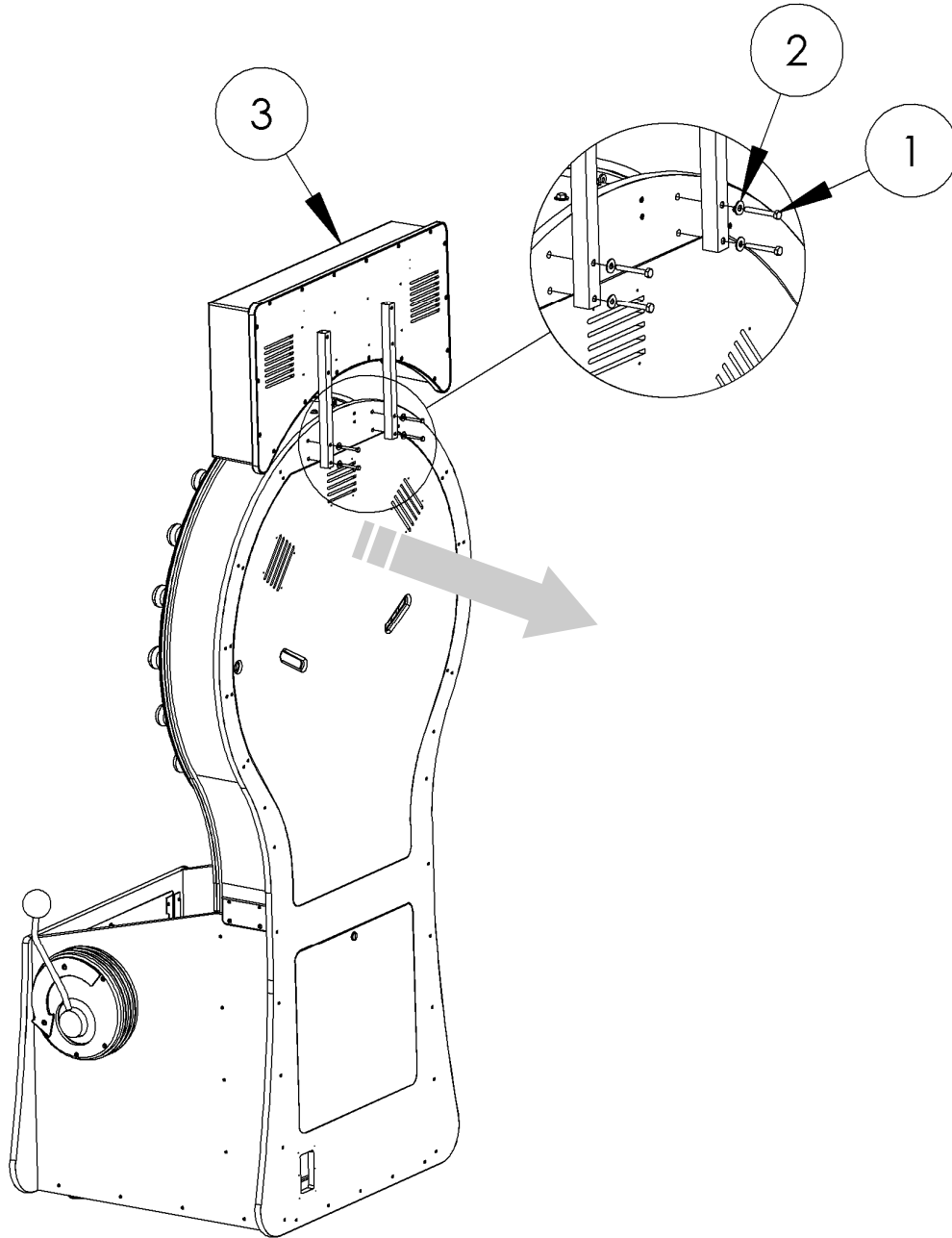

ITEM NO.	PART NO.	DESCRIPTION	QTY.
1	6082	1/4-20 x 2 Hex Head Machine Bolt	4
2	6075	1/4 x 3/4 FLAT WASHER	4
3	PW3132X	MARQUEE ASSEMBLY	1

SETUP - Programming

Game Play

The object of the game is to stop the light ring on any of the three bonuses to win the amount of tickets shown in the center of the light ring. The player begins by inserting the correct amount of coinage required to start a game. Then the player pulls the large level to begin the light ring's motion. The large red button will begin to flash. Pressing this button will stop the light ring giving the value of the tickets for that pie. If the light ring was stopped at the bonus pie, the player wins the bonus tickets displayed in the center of the light ring.

Credits required to play and Payout Percentages

The game has ticket payouts that are divided into 24 sections or pies. There are three bonus pies in addition to the 24 pies for a total of 27. Each of the three bonus pies can be configured different for their difficulty. When the game arrives the graphics will be installed for a two credit game (.50 cents US) assuming your location is using a .01 cent ticket. If you desire to change the credit required to start a game, you will have to change the payout graphics. When your game arrived a decal package should have been included (ICE part numbers PW7115 and PW7116). These two packages should contain all the possible numbers required to change the payout pies to the required setup. Remove the graphics already installed and discard. Peel and apply the stickers to the recommended pie. Refer to the next page for ICE recommendations:

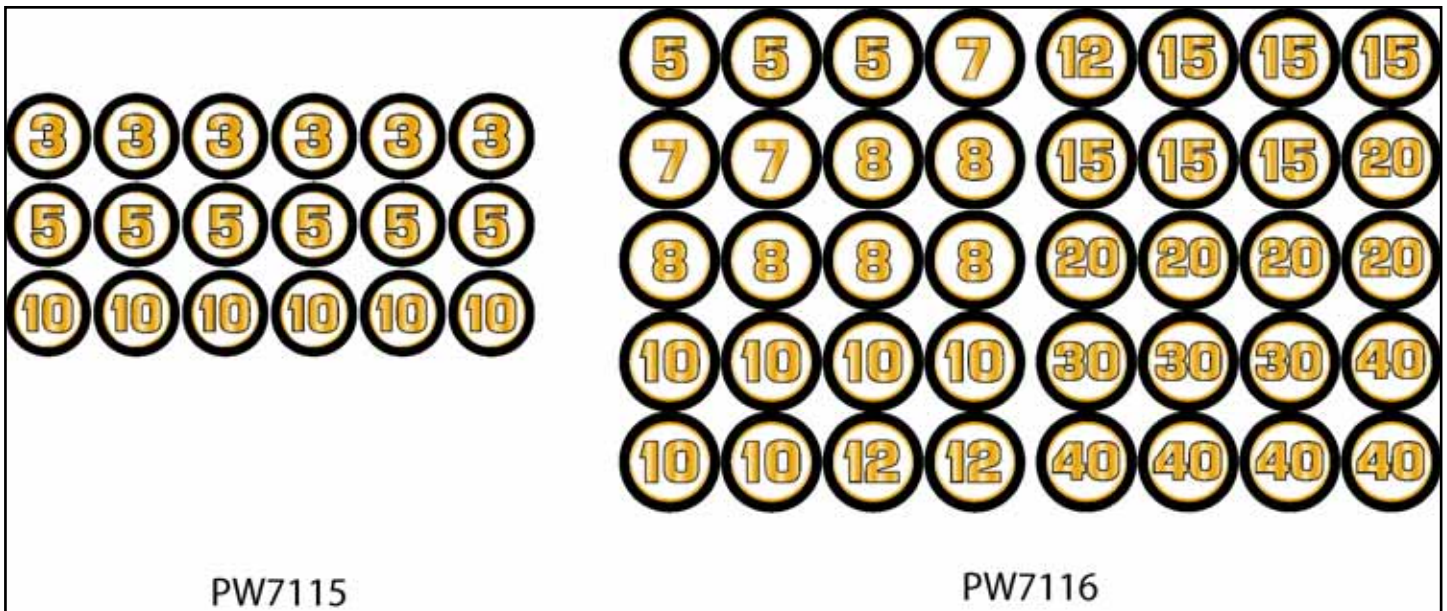

TICKETS

Your game has the capacity to hold up to 16 thousand tickets giving you plenty of play between collections. This game features automatic detection of tickets and will pay out whatever is owed to the customer when tickets are replaced. The game will dispense tickets from both dispensers at the same time. When loading tickets it is recommended to balance them between both ticket dispensers. The total number of tickets paid out are kept by the Ticket meter located in the coin door.

GAME PLAY SET VALUE

1 EURO

BIG WIN
SUPER SPIN



GAME PLAY SET VALUE

1 POUND

BIG WIN
SUPER SPIN



PAYOUT PERCENTAGE SET TO:

20P

BIG WIN
SUPER SPIN



PAYOUT PERCENTAGE SET TO:

30P

BIG WIN
SUPER SPIN



GAME PLAY SET VALUE

50 CENT EURO

BIG WIN
SUPER SPIN



PAYOUT PERCENTAGE SET TO:

SOP

BIG WIN
SUPER SPIN



GAME PLAY SET VALUE

100 EURO

BIG WIN
SUPER SPIN



PROGRAMMING YOUR BIG WIN SUPER SPIN - *Software game version 1.0 Italy*

The program button is located inside the coin door next to the ticket and coin meters. Press this button to enter programming. The top display shows the current value held for that option. To cycle through your options use the large red button on the control panel. To accept the current value shown on the LED screen press the pull arm on the side of the cabinet to advance to the next option. This game has its coin wiring cash flow ready. Other options are available. Contact your ICE sales representative for details. Refer to the chart below.

Option	Default	Minimum	Maximum	Description
Volume	5	0	8	Sets the volume level for the game.
Coin Input 1	2	0	9	Sets how many pulses to start a game.
Coin Input 2	0	0	9	Sets how many pulses to start a game.
Coin Input 3	0	0	9	Sets how many pulses to start a game.
Coin Input 4	0	0	9	Sets how many pulses to start a game.
Coin Input 5	0	0	9	Sets how many pulses to start a game.
Coin Input 6	0	0	9	Sets how many pulses to start a game.

**** NOTE **** There are six coin lines to allow different values of coinage per line. For example the default has coin input 1 set for 2 and a standard US coin mechanism installed in the coin door. When the customer wishes to play the game they will be required to insert two coins (.50 cents) to start the game.

Coin Discounting	0	0	9	This option is used to create "Bonus Credits". The way this option works is as follows: if a "3" is set, for every 3 coins put in AT THE SAME TIME, 1 extra credit would be given. The range for this option is 0-9. Setting a "0" turns this option off. The default value for this option is "0".
Bonus Thousands	1	0	9	
Bonus Hundreds	0	0	9	
Bonus Tens	0	0	9	
Difficulty Top	2	1	5	These options sets the difficulty of play. A setting of 1 is the most difficult where a setting of 5 is the easiest.
Difficulty Right	2	1	5	
Difficulty Left	2	1	5	

On all the pie wedges there will be P for pie and the light will light up corresponding with what that option refers to. Be sure to match the numbers to the whatever sticker you have applied.

Pie 1	5	0	99
Pie 2	10	0	99
Pie 3	20	0	99
Pie 4	5	0	99
Pie 5	15	0	99

PROGRAMMING YOUR BIG WIN SUPER SPIN - *cont.*

Option	Default	Minimum	Maximum	Description
Pie 6	20	0	99	
Pie 7	10	0	99	
Pie 8	5	0	99	
Pie 9	5	0	99	
Pie 10	10	0	99	
Pie 11	20	0	99	
Pie 12	5	0	99	
Pie 13	15	0	99	
Pie 14	20	0	99	
Pie 15	10	0	99	
Pie 16	5	0	99	
Pie 17	5	0	99	
Pie 18	10	0	99	
Pie 19	20	0	99	
Pie 20	5	0	99	
Pie 21	15	0	99	
Pie 22	20	0	99	
Pie 23	10	0	99	
Pie 24	5	0	99	
Attract Time	3	3	99	
Auto Window	0	0=Off	500	How many plays before the jackpot window opens up.
Games 2 Dec	0	0=Off	100	This sets how many games must be Played before increasing the ticket bonus jackpot determined in the next setting.
Tickets Inc	1	1	10	This sets how many tickets to add to the jackpot when a player misses the bonus pie.
Factory Default	0	0	1 = Reset	Reset all settings back to defaults.

POWER SUPPLY INFORMATION

DA2001X - DC power supply
DA2002X - Transformer for DC power supply
PX2002CEAX - Step down transformer

6 AMP Slow Blow main AC power

TROUBLESHOOTING

Troubleshooting

CAUTION

This game uses complex electronic components that are very sensitive to static electricity. Observe precautions below before handling these electronics. Failure to do so may void the warranty and damage electronic assemblies.

Before servicing electronics, turn off AC power to the game. Wait for capacitors to discharge.

DO NOT remove any of the components on the main board (e.g. compact flash and eproms) while the game is powered on. This may cause permanent damage to the parts and the main board.

Before touching or handling electronic assemblies, discharge static electricity on your body. To discharge this static, begin by connecting the line cord to a grounded outlet. Don't turn on the game. Next, touch the safety ground stud of the power supply chassis.

Store electronic assemblies in an anti-static area. Use anti-static bags to store or transport the game circuit boards.

Don't remove or connect electronic assemblies when cabinet power is on. Otherwise, you'll damage electronic assemblies and void the game's warranty.

After you complete maintenance or service, replace ground wires, shields, safety covers and install and tighten ground and mounting screw.

Fuses - Main Power Supply

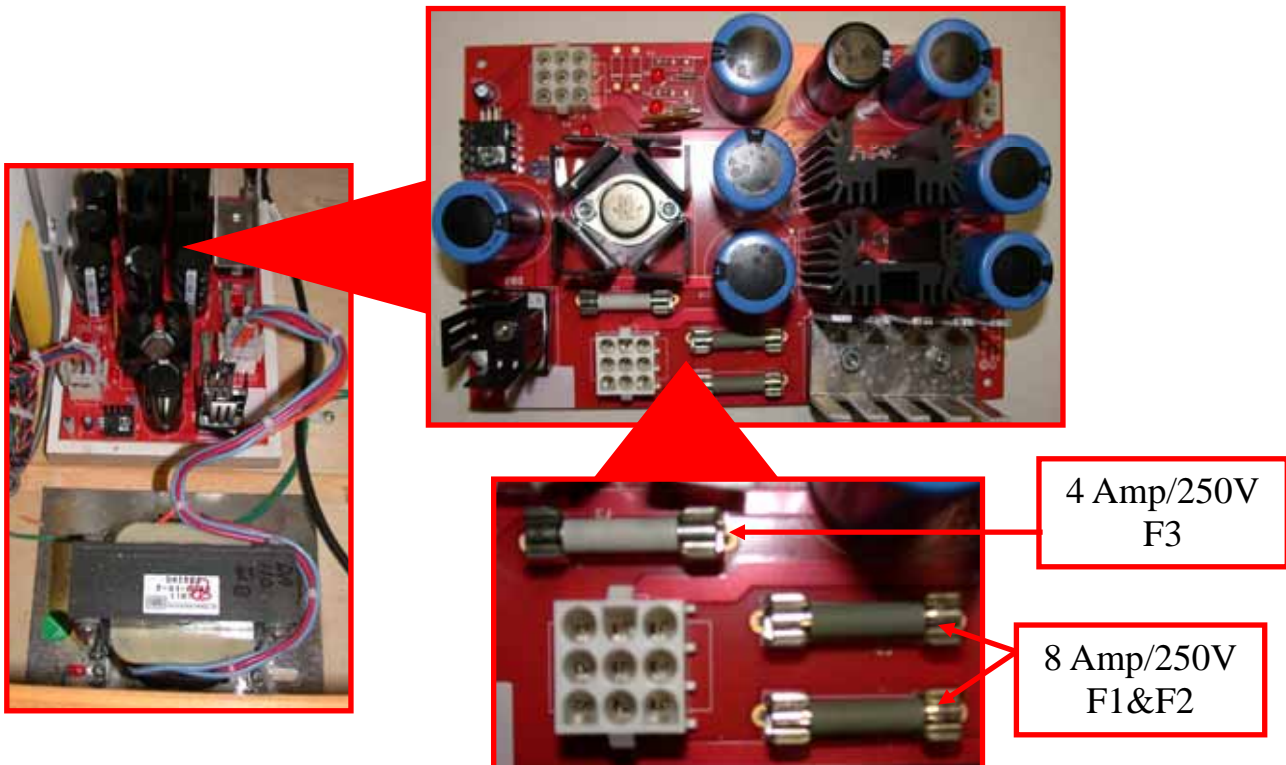

ASSEMBLIES AND DRAWINGS

ITEM NO.	PART NUMBER	DESCRIPTION	QTY.
1	PW3101	SIDE WHEEL COVER	2
2	PW3110,11	R SIDE WHEEL COVER CLEAT	1
3	PW3111	R SIDE WHEEL COVER CLEAT	1
4	PW3119X	LEVER ARM ASSY	1
5	PW3132X	MARQUEE ASSY	1
6	PW3133	SIDE WHEEL COVER CLEAT	1
7	PW3178X	ASSY - WOOD CABINET	1
8	AR2007	SPEAKER (ROHS) (6x9)	2
9	FZ1119	SPEAKER GRILL	2
10	6075		8
11	6082	1/4-20 x 2.0" LG. HH BOLT	4
12	PC60604	NYLOCK NUT, 1/4-20	4
13	6212	1/4 x 3/4 FLAT WASHER BLACK	4
14	6386	HBOLT 0.2500-20x0.75x0.75-N	4
15	6630	1/4-20 x 4" SHCS	4
16	655S	#8 x 5/8 SQ. DRIVE (SILVER)	23
17	6004a	8-32 KEP NUT	4
18	6102	1/4-20 x 1 1/2 BSHCS (ZINC)	2
19	6272	BHCS #8-32 x 1.25" LG. (BLACK OXIDE)	4
20	PC60622	SBHCS 025-20x1	4
21	MM5001	cash box	1
22	CG1009	CASH BOX LID	1
23	MM1058	1/2 COIN DROP CATCHER	2
24	PW3109	Kick Plate	1
25	PW3103X	ASSEMBLY - LIGHT RING	3
26	6263	BHCS #8-32 x .75" LG. (BLACK OXIDE)	3
27	PW7101	DECAL-WHEEL / PLAYFIELD	1
28	PE2034	XXXXX	1
29	6419	6-32 x 1 PEM STUD (FH-632-16ZI)	1
30	644	6-32 x 1/2" HH NYLON SPACER	1
31	641	6-32 x 1/4" LG. PRHMS	1
32	PC60624	PARTICLE BRD SCREW 2" LG	1
33	PW3100X	ASSEMBLY - CONTROL PANEL	1



ITEM NO.	PART NUMBER	DESCRIPTION	Default/Q Ty.
1	PW3153	UPPER ACCESS DOOR	1
2	5014C	LOCK (710-010-01B)	2
3	655S	#8 x 5/8 SQ. DRIVE (SILVER)	24
4	PW3106X	ASSEMBLY - DISPLAY	1
5	6030	DRYWALL SCREW 1.25	3
6	TG1021	LIGHT BRACKET	6
7	E00382	BULB CF 27W (PHILIPS #EL/MDT27W	6
8	PW2130X	ASSEMBLY-CERAMIC BULB SOCKET	6
9	6061	8-32 CAB INSERT (J-50111)	2

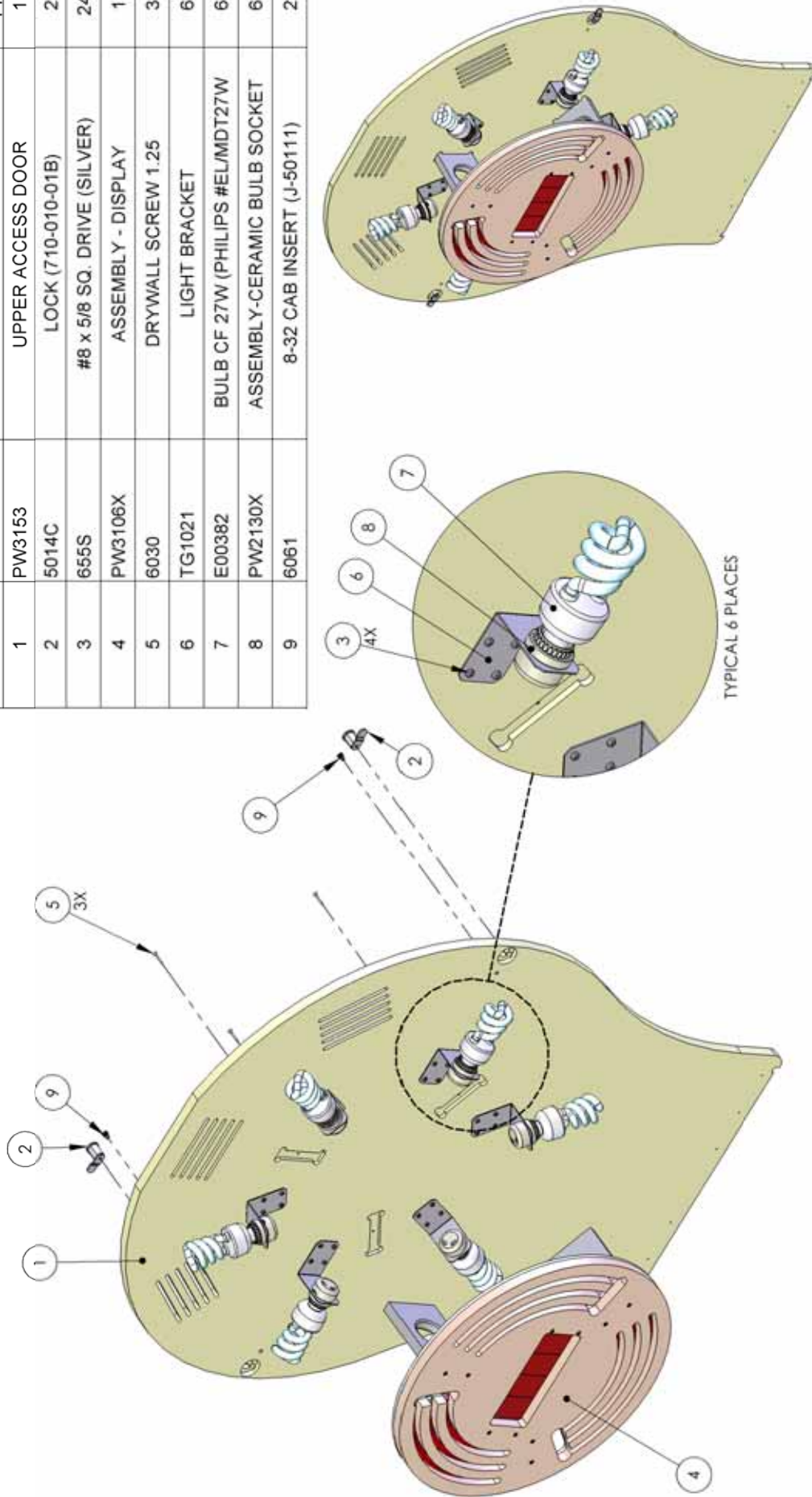

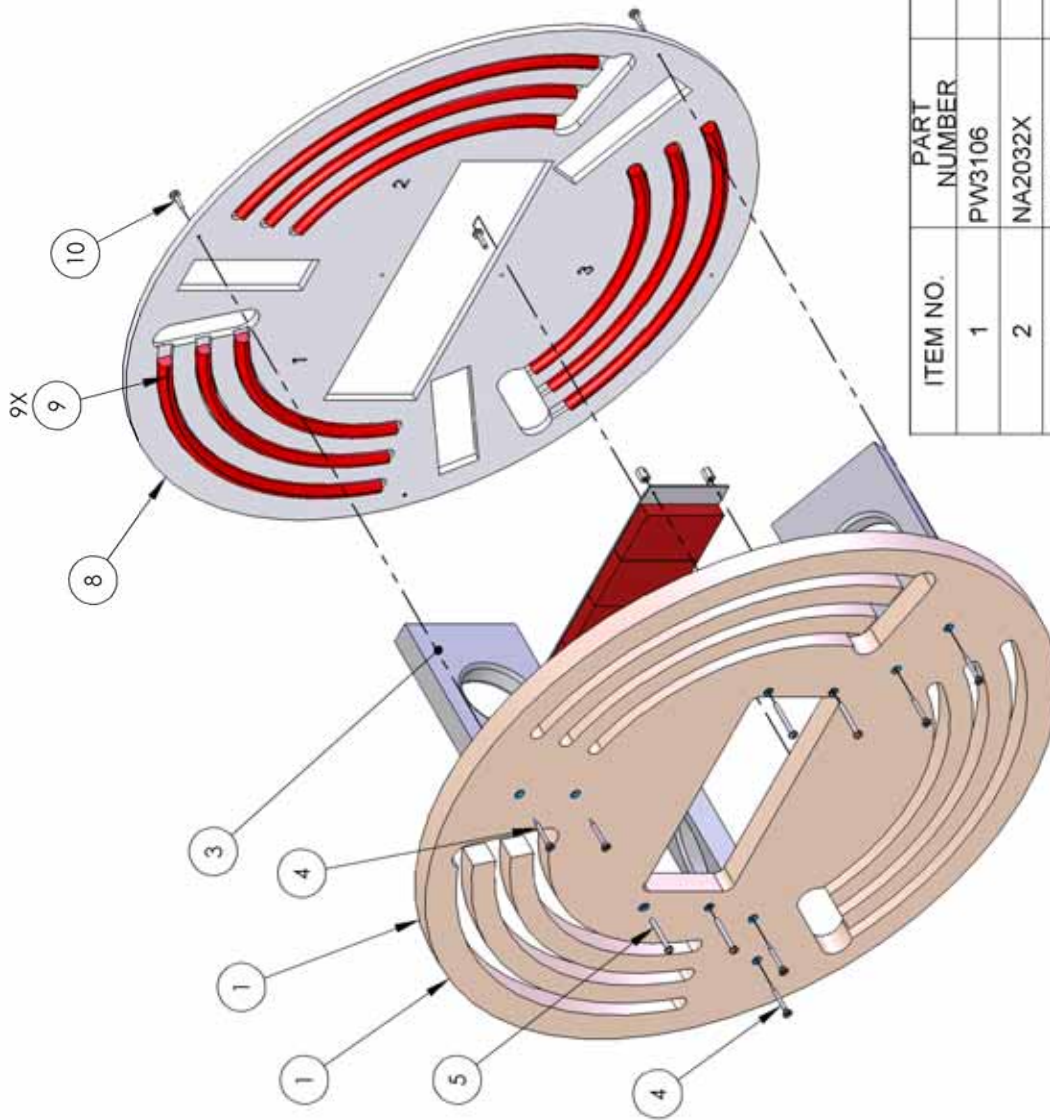

FRONT (ISO) VIEW

ITEM NO.	PART NUMBER	DESCRIPTION	QTY.
1	PW3106	CENTER PLATE	1
2	NA2032X	PCB (DISPLAY)	1
3	PW3108	DOOR STOP	3
4	6030	DRYWALL SCREW 1.25	6
5	6109	6-32 x 1-1/4" LG. PPHMS	4
6	PC60642	6-32 x 3/8 HH SPACER 14HTSP007	4
7	PC60643	6-32 x 1/4 HH SPACER	4
8	PW3114	CENTER BACKPLATE	1
9	E00416PWX	ASY (LED STRIP, RED)	9
10	655S	#8 x 5/8 SQ. DRIVE (SILVER)	6

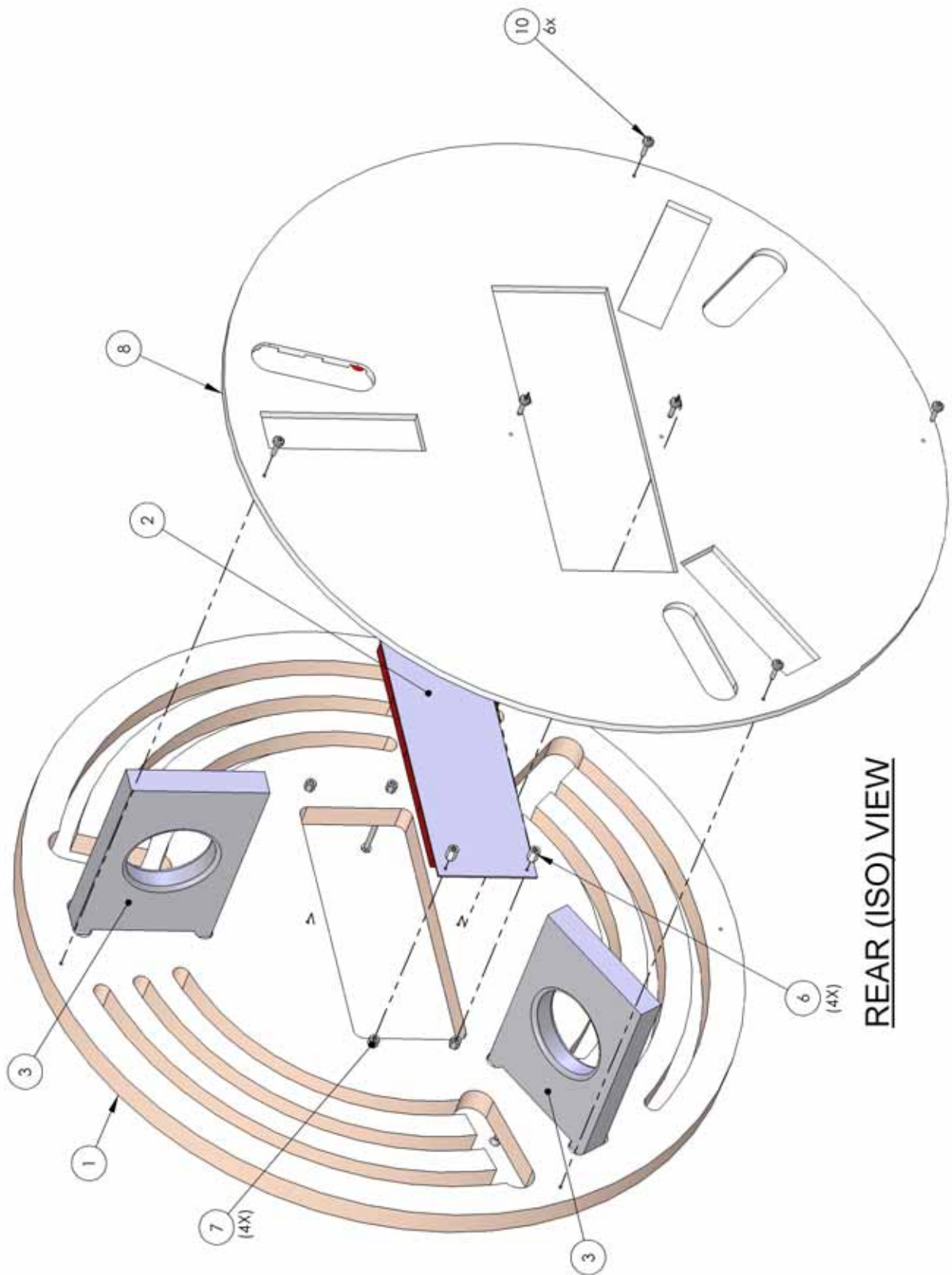

REAR (ISO) VIEW

ITEM NO.	PART NUMBER	DESCRIPTION	QTY.
1	PW3103	WHEEL FRAME	1
2	PW3104	LIGHT WEDGE	1
3	PW7104	RING 'A'	1
4	PW2007W	WHITE MINI FUNLIGHT BULB ASY, (211MINIUNITW)	20
5	6348	8-32 X 1.75 PHMS	6
6	E00053	LED, E10, CLUSTER OF 6	20
7	6042	FLUSH HEAD STUD #10-24 X .750	1
8	6040	10-24 KEP NUT	2
9	PW2007R	RED MINI FUNLIGHT BULB ASY, (211MINIUNITR)	1

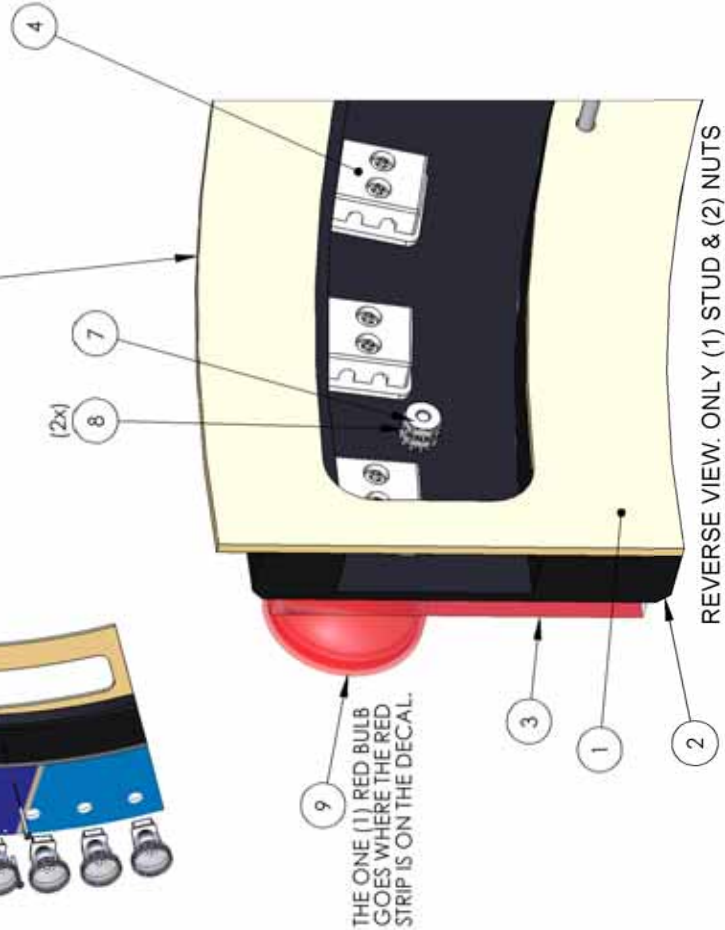
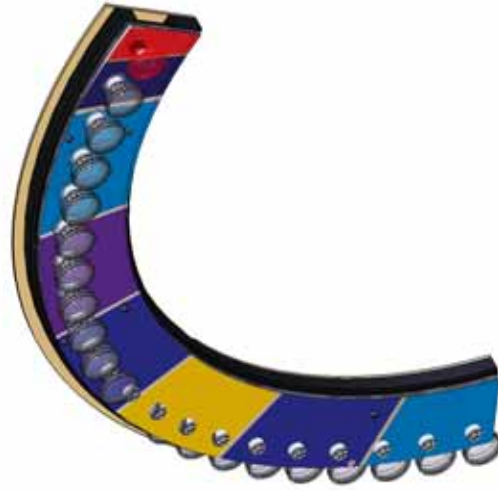
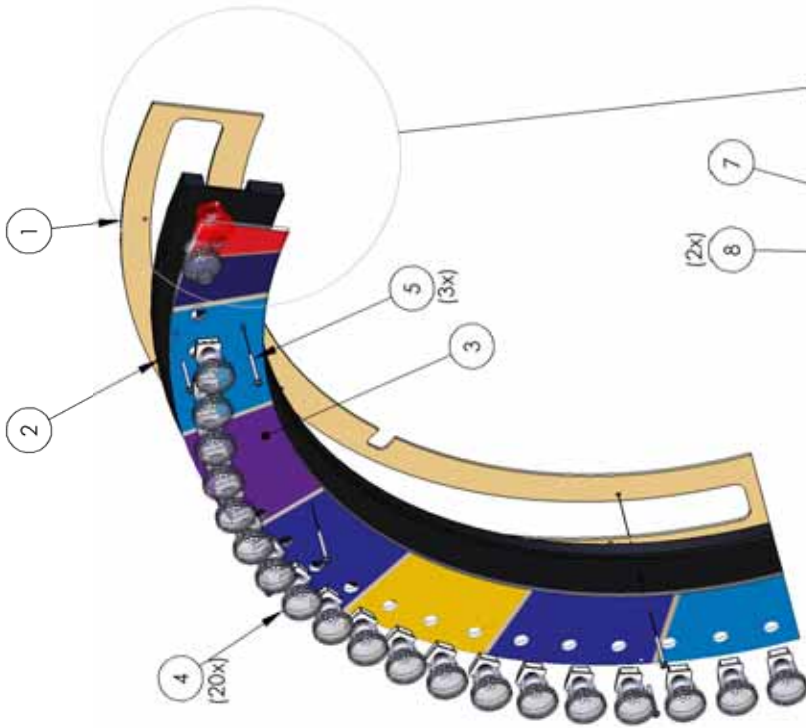

REVERSE VIEW. ONLY (1) STUD & (2) NUTS
REQUIRED PER ASSEMBLY. ORIENTATION
IS IMPORTANT HOWEVER.

ITEM NO.	PART NUMBER	DESCRIPTION	QTY.
1	MZ3023	MARQUEE HOUSING	1
2	PW7127	MARQUEE	1
3	6041	8/32 x 5/8 PEM STUD FH 832-10	14
4	6004a	8-32 KEP NUT	14
5	PW3182X	MARQUEE BACK ASSEMBLY-BWSS	1
6	6155	#8-32 x 7/8" PHMS	18



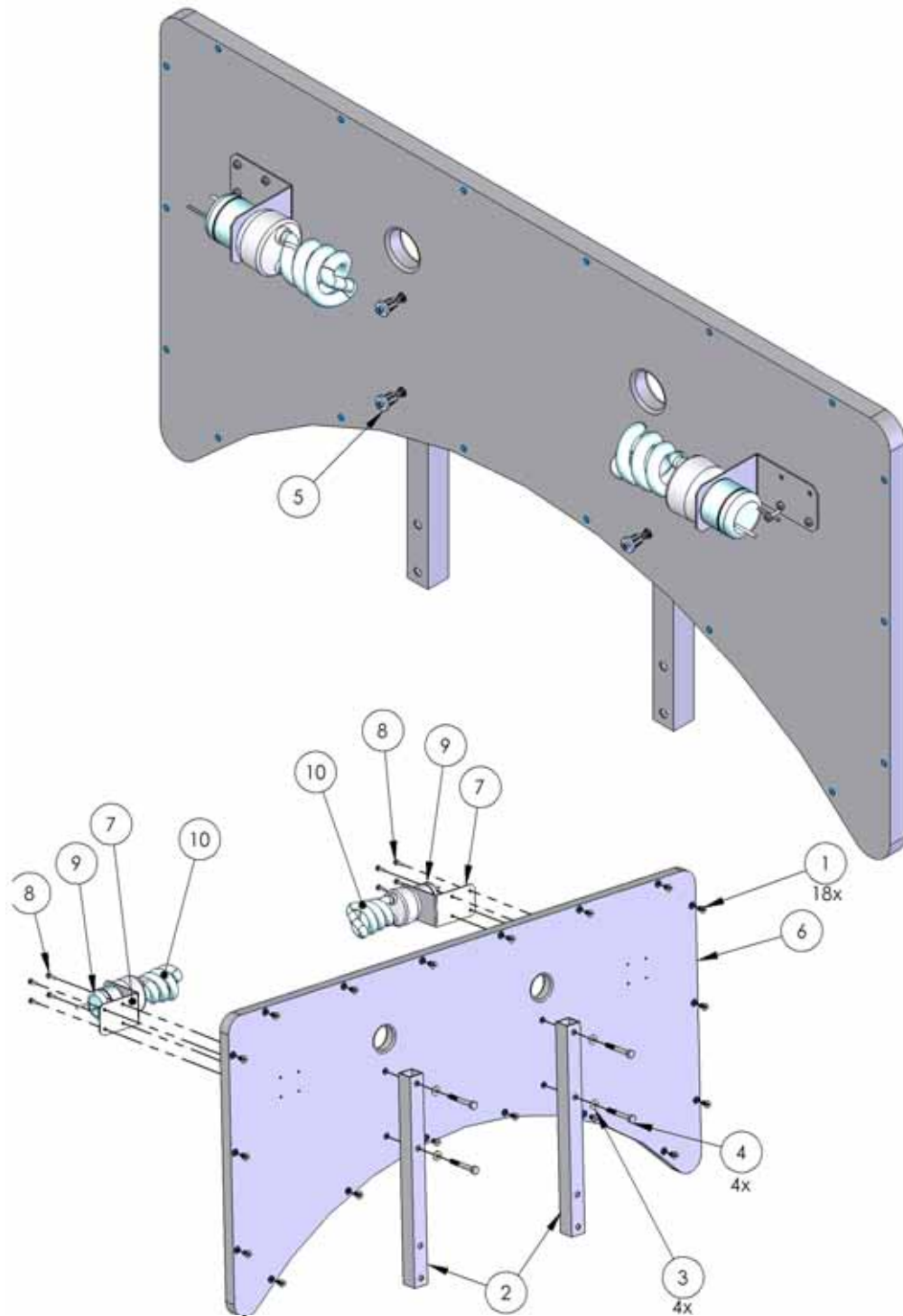

ITEM NO.	PART NUMBER	DESCRIPTION	QTY.
1	6061	8-32 CAB INSERT (J-50111)	18
2	PW1012	MARQUEE BRACKET	2
3	6057	1/4 X 1/2 X .062 FLAT WASHER	4
4	6069	1/4-20 x 2 HH BOLT (3/4 THR)	4
5	PC60631	025-20 CABINET INSERT (J50115)	4
6	PW3182	MARQUEE BACK-BWSS	1
7	TG1021	LIGHT BRACKET	2
8	655S	#8 x 5/8 SQ. DRIVE (SILVER)	8
9	SH2130X	ASY (2D BULB SOCKET)	2
10	E00382	BULB CF 27W (PHILIPS #EL/MDT27W)	2

ITEM NO.	PART NUMBER	DESCRIPTION	QTY.
1	PW3157X	ASSEMBLY-CONTROL PANEL 'A'	1
2	PW3158	CONTROL PANEL	1
3	PW3183X	ASSEMBLY-CONTROL PANEL 'B'	1
4	PW7112	CONTROL PANEL OVERLAY	1
5	PW3083X	ASSEMBLY-BUTTON SUPPORT PANEL	1
6	6261	1/4-20 X 2 1/4" BHCS	5
7	6220	1/4-20 x 1-3/4 BSHCS (BLACK)	4
8	PW3122	BUTTON RING	1

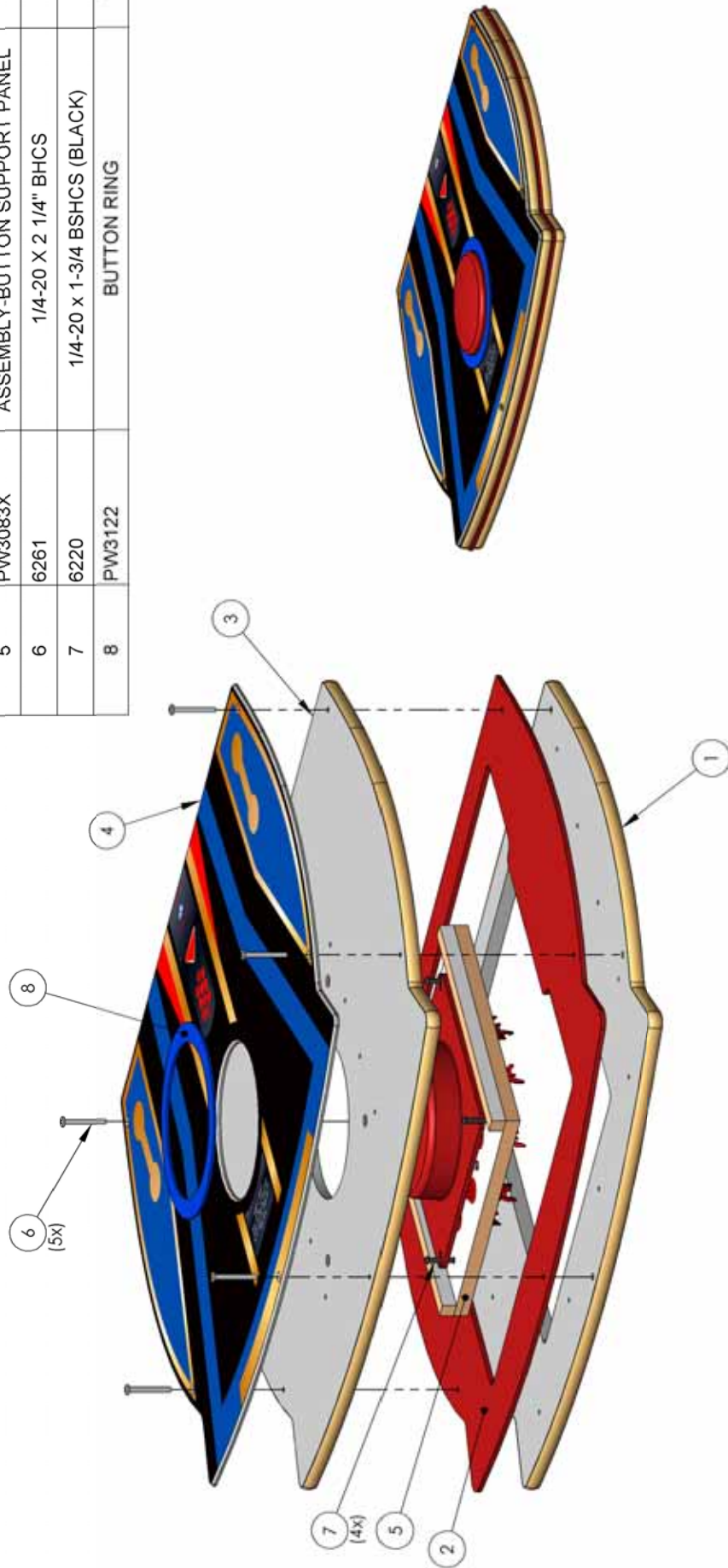

ITEM NO.	PART NUMBER	DESCRIPTION	QTY.
1	PW3118	LEVER ARM TOP RING	1
2	6380	#4 X 3/8" PH PAN TY AB SCREW	3
3	PW3113	CONTROL PANEL PULL LEVER ARROW	1
4	6020	#10 FLAT WASHER-ZINC	4
5	6102	1/4-20 x 1 1/2 BSHCS (ZINC)	4
6	PC60604	NYLOCK NUT, 1/4-20	4
7	PW3041	CHROME PLATED COVER (12-1510-8 HAPP)	1
8	PW1051	PREMIER HANDLE MECHANISM VERTICAL (HAPP)	1
9	PW3042	HUB (12-1200-8 HAPP)	1
10	6625	HANDLE MECH BOLT (678-101-700 HAPP)	1
11	6226	1/4-20 x 1 SHCS	3
12	6430	#10 FLAT WASHER, BLACK (1/4-20)	3
13	PC60631	025-20 CABINET INSERT (J50115)	3
14	PW1050	LONG HANDLE BALL ASSEMBLY (12-1318 HAPP)	1
15	PW3040	3" TRACKBALL, RED, HAPP #55-0200-10	1
16	PW7113	DECAL - LEVER ARROW	1

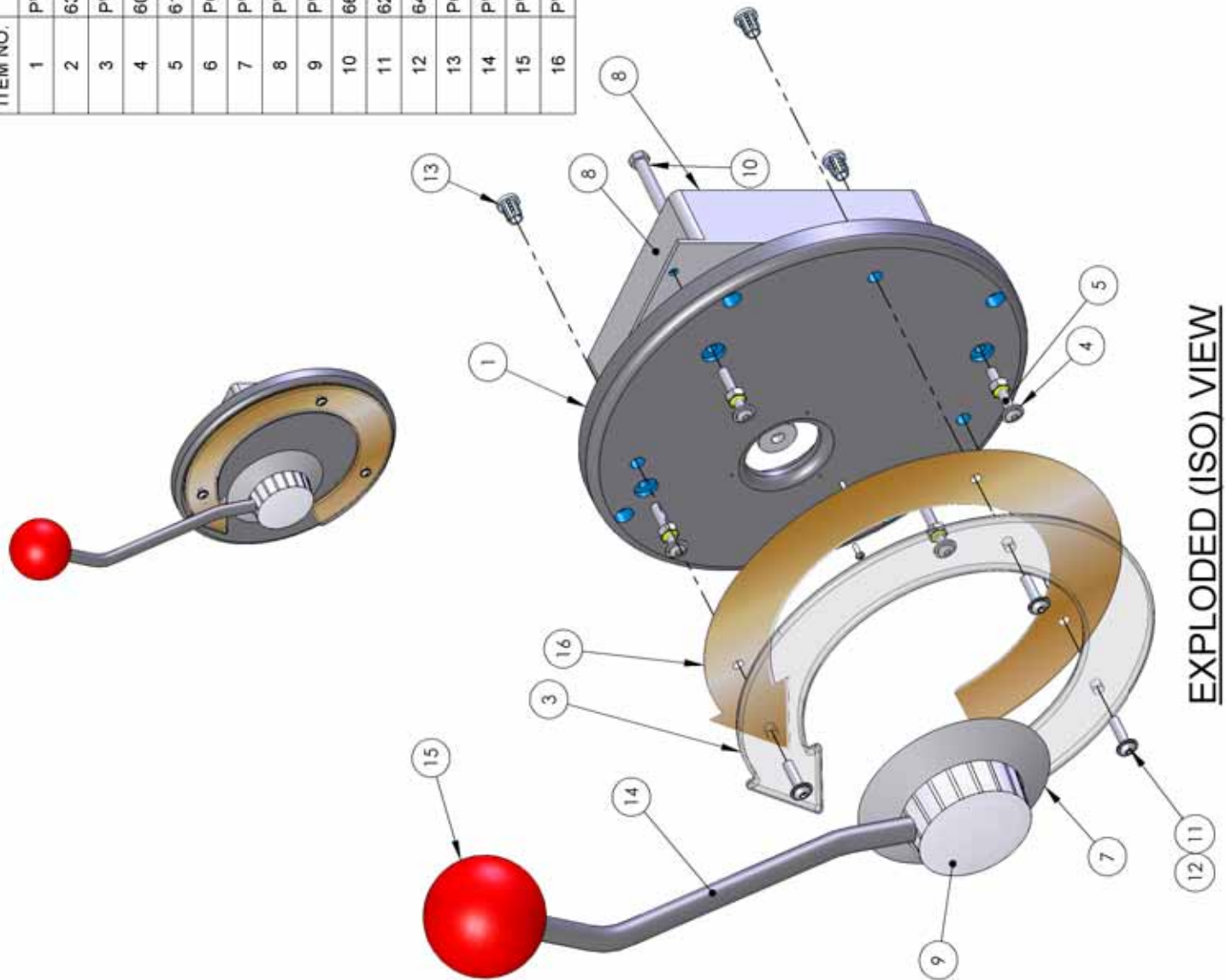

EXPLODED (ISO) VIEW

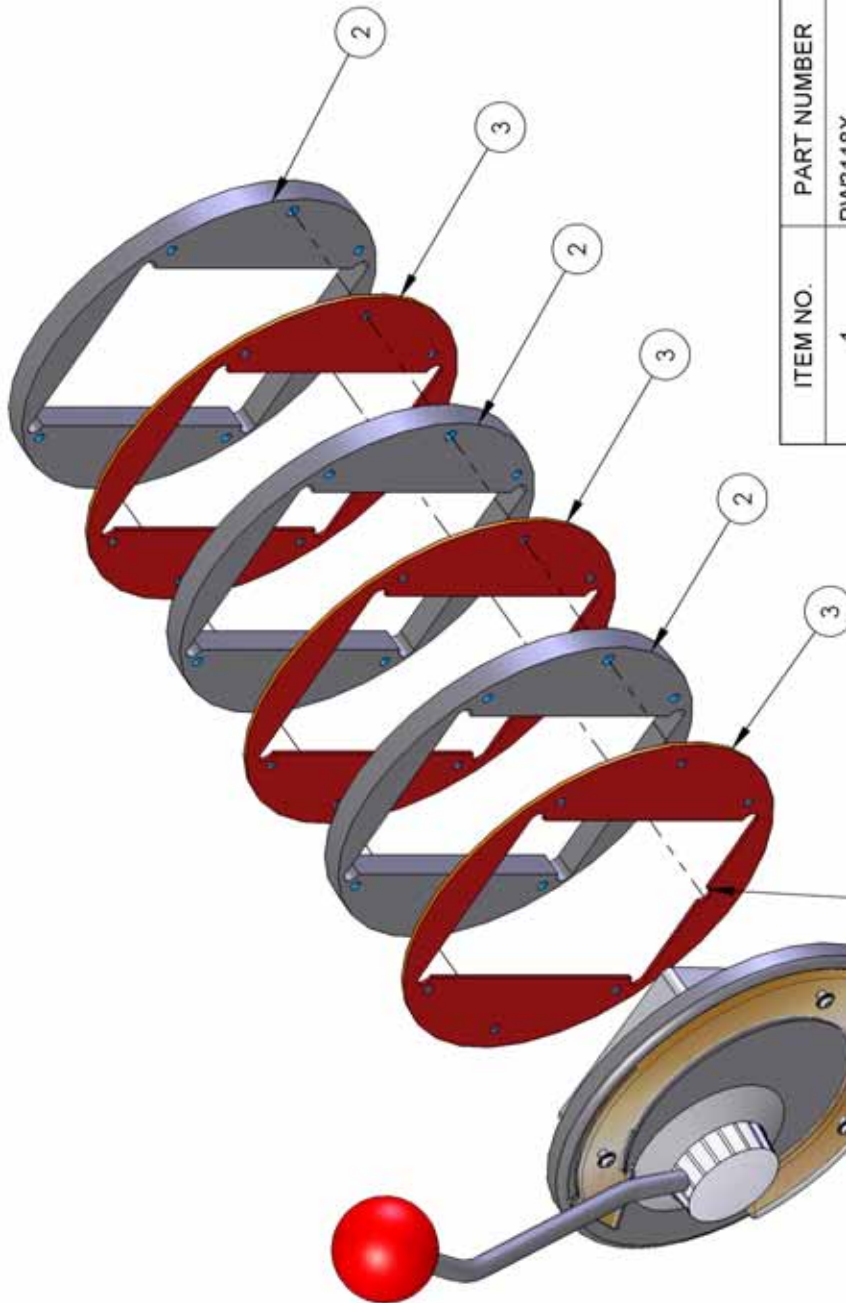
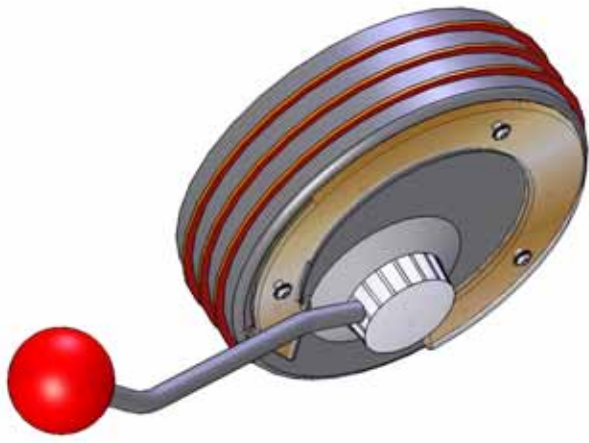

ITEM NO.	PART NUMBER	DESCRIPTION	QTY.
1	PW3118X	LEVER ARM TOP RING ASSY	1
2	PW3119	LEVER ARM MID-RING	3
3	PW3120	LEVER ARM LIGHT RING	3

ALIGN ALL NOTCHES
FOR PROPER ASSEMBLY
6 PLCS.

EXPLODED VIEW

PW1051 Spring Part Break Down

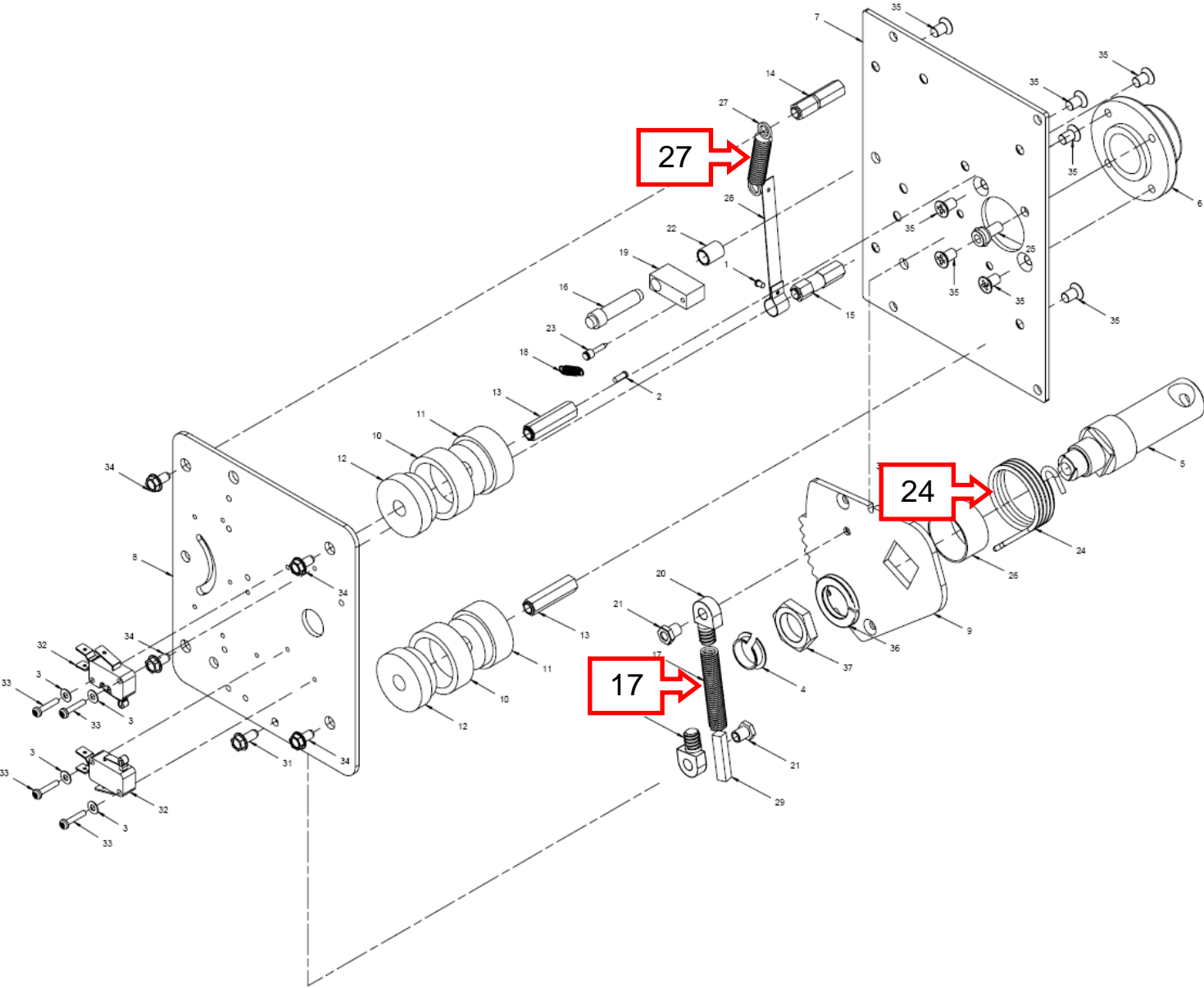

<i>ICE PART</i>	<i>Description</i>	<i>Location</i>
PW1052	Spring Stop	(Part 27 above)
PW1053	Spring Torsion	(Part 24 above)
PW1054	Spring Main	(Part 17 above)

MAINTENANCE / REPAIR

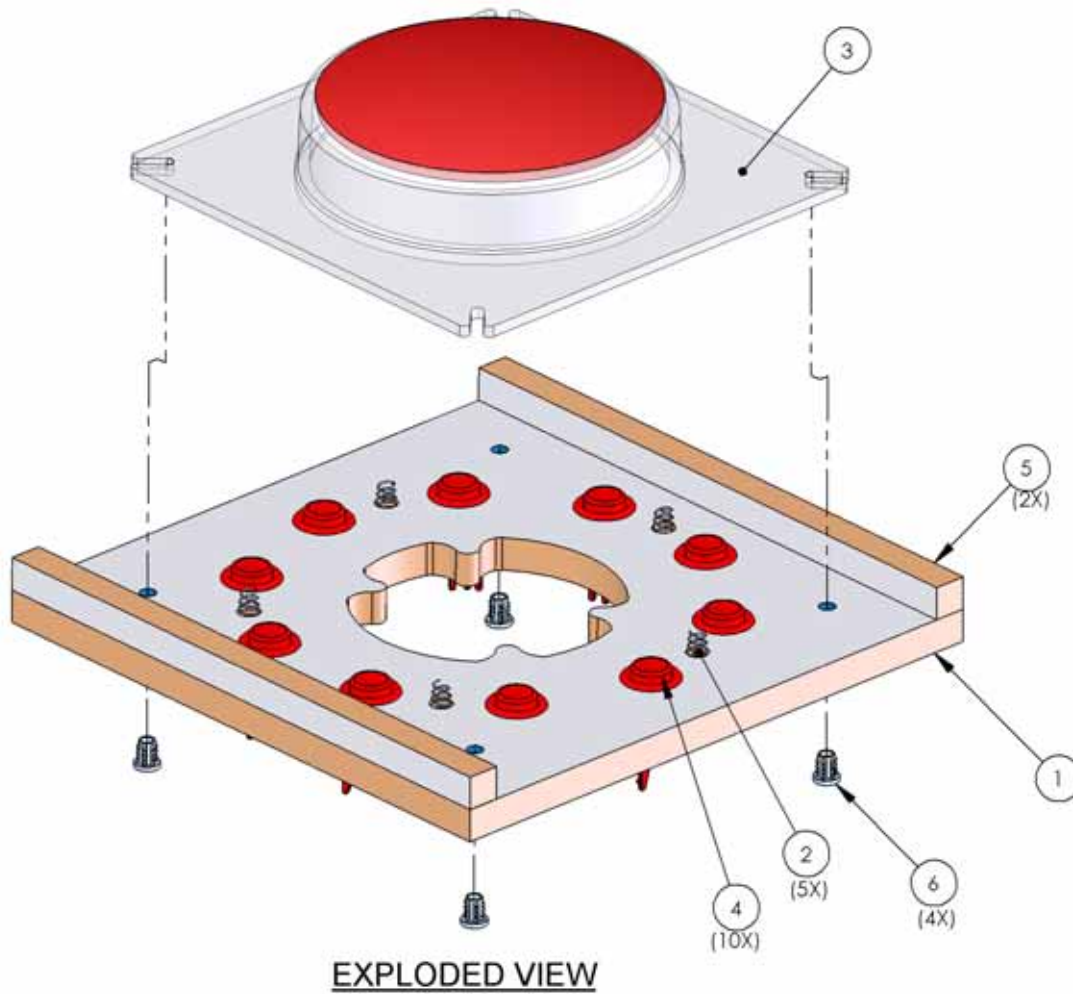

ITEM NO.	PART NO.	DESCRIPTION	QTY.
1	PW3083	BUTTON SUPPORT PANEL	1
2	CG1066	.700 X .3125 SPRING	5
3	BW3003	8" PUSH BUTTON	1
4	EV2005	RED SOLID BUTTON	10
5	PW3084	PUSH BUTTON CLEAT	2
6	PC60631	1/4-20 CABINET INSERT	4

PARTS LISTINGS

Misc. Parts

PW1050	Handle
PW1051	Handle Mechanism
PX1007-P802	Ticket door
PX1050	Drawer slide 12"

Electrical Parts

DA2001X	PCBA Power supply
DA2002CEX	PCBA Transformer for DA2001X
MS2002CEAX	Step down Transformer
1029CLX	Reset Assembly
E02295	Fuse 6 amp 250v Slow Blow
E00211	Low Ticket switch
E00382	Bulb
PE2034X	Main I/O board (requires E2034X and E08716 to function)
E2034X	ARM 7 CPU Brain Board
E08716	Flash Card (Request software version)
HH5005	Ticket Dispenser
PW2130X	Socket Assembly
PW3040	3" Tack ball red
PW3041	Cover Plate
PW3042	Hub
2145	Bulb
BW3003	Large red plastic button (plastic only)
PW2007R	Red mini Fun light bulb assembly
PW2007W	White mini Fun light bulb assembly
E00053	LED, E10, Cluster of 6
E00416PWX	LED strip Red assembly
NA2032X	PCB display
E00382	Bulb CF 27W
PW7127	Marquee BWSS
SH2130X	Ceramic socket assembly
PW3083X	Large Button support panel

Graphics and Decals

PW7104	Decal - Ring A
PW7101	Wheel / Playfield
PW7102	Front Door
PW7105	Ticket Door
PW7112	Control Panel
PW7113	Control Panel Pull lever
PW7115	Wheel Value (small)
PW7116	Wheel value (large)

Warranty

I.C.E warrants all components in the **Big Win Super Spin™** game to be free of defects in materials and workmanship for a period of ninety days from the date of purchase.

This warranty does not cover items damaged due to normal wear and tear, subjected to abuse, improperly assembled by the end user, modified, repaired, or operated in a fashion other than that described in the service manual.

If your **Big Win Super Spin™** game fails to conform to the above-mentioned warranty, I.C.E.'s sole responsibility shall be at its option to repair or replace any defective component with a new or remanufactured component of equal to or greater O.E.M. specification.

I.C.E. will assume no liability whatsoever, for costs associated with labor to replace defective parts, or travel time associated therein.

I.C.E.'s obligation will be to ship free of charge, replacement parts by domestic U.P.S. Ground, U.S. mail, or other comparable shipping means. Any express mail or overnight shipping expense is at the cost of the purchaser.

Products will be covered under warranty only when:

- The serial number of the game with the defective parts is given. A tech number has been issued by an I.C.E. technical representative.
- The serial number of the defective part, if applicable, is given.
- Defective parts are returned to I.C.E., shipping pre-paid, in a timely fashion, if requested by I.C.E.
- A copy of the sales receipt is available as proof of purchase upon request of I.C.E.

I.C.E. distributors are independent, privately owned and operated. In their judgment, they may sell parts or accessories other than those manufactured by I.C.E. We cannot be responsible for the quality, suitability, or safety of any non-I.C.E. part, or any modification, including labor, which is performed by such a distributor.



WARRANTY

ICE Inc warrants that all of its products will be free from defects in material and workmanship.

When placing a warranty request, please be prepared to provide the following information:

- Serial Number of Game or Bill of Sale
- Machine Type
- A Detailed Description of the Equipment Fault Symptoms

ICE product, including Cromptons, Sam's Billiards, Uniana and Bell Fruit is warranted as follows:

- 180 days on the Main PCB and Computers
- 180 days on Motors
- 180 days on Monitors
- 90 days on all other components (i.e. DBV's, Ticket Dispensers, sensors, etc)

ICE Inc shall not be obligated to furnish a warranty request under the following conditions:

- Equipment has been subjected to unwarranted stress through abuse or neglect
- Equipment has been damaged as a result of arbitrary repair/modification attempts
- Equipment that has failed through normal wear and tear

ICE Inc will assume no liability whatsoever for costs associated with labor to replace defective parts or travel time associated therein.

All defective warranty covered components will be replaced with new or factory refurbished components equal to OEM specifications. ICE Inc will cover all domestic UPS ground, or comparable shipping means, freight costs during the warranty period. Expedited shipments are available for an additional charge.

Defective parts are returned to ICE Inc, at the customer's expense, in a timely fashion.

ICE distributors are independent, privately owned and operated. In their judgment, they may sell parts and/or accessories other than those manufactured by ICE Inc. We cannot be responsible for the quality, suitability or safety of any non-ICE part, modification (including labor) that is performed by such a distributor.

I.C.E. Parts/Service Dept.
Innovative Concepts in Entertainment
10123 Main St.
Clarence, NY 14031
Phone #: (716) - 759 - 0360
Fax #: (716) - 759 - 0884