

# namco®



## ACE DRIVER DELUXE

### Installation and Commissioning Manual

IT IS THE RESPONSIBILITY OF THE OPERATOR TO MAINTAIN CUSTOMER SAFETY AT ALL TIMES, AND IT IS IMPERATIVE THAT THE DETAILS SET OUT IN THIS MANUAL ARE FOLLOWED PRECISELY.

© 1994 **namco** Ltd - all rights reserved.

No part of this publication may be reproduced by any mechanical, photographic or electronic process, or in the form of phonographic recording, nor may it be stored in a retrieval system, transmitted or otherwise copied for public or private use, without permission from **namco** Ltd.

While the information contained in this manual is given in good faith and was accurate at the time of publication, BRENT LEISURE LIMITED reserve the right to make changes and alterations without notice.

This machine has been manufactured in accordance with European Community directives (1st. January 1995), and as such bears the **CE** marking. Any changes or modifications to this machine must be in accordance with European Community directives (1st. January 1995).

If you make any unauthorised changes to this product, you may contravene European Community directives (1st. January 1995)

Published by:  
BRENT LEISURE Ltd.  
Unit 1 Brent Crescent,  
London. NW10 0QT

Phone:- 0181-965-0550  
Fax:- 0181-961-0574

This machine is designed for **indoor** use only. **Do not** install the machine in the following places.

① Outdoors.

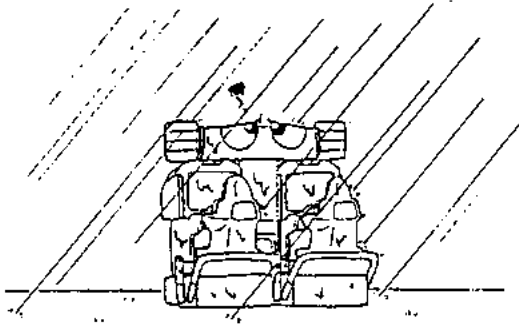

② Direct sunlight, places with excessive humidity or dust, places where there is water leakage, near air-conditioning or heating equipment, places with excessively high or cold temperature.

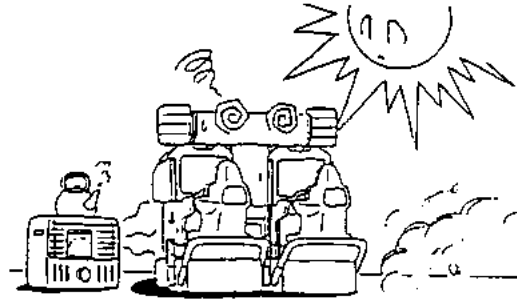

③ Places where it would be in the way of emergency exits or fire extinguishing equipment.

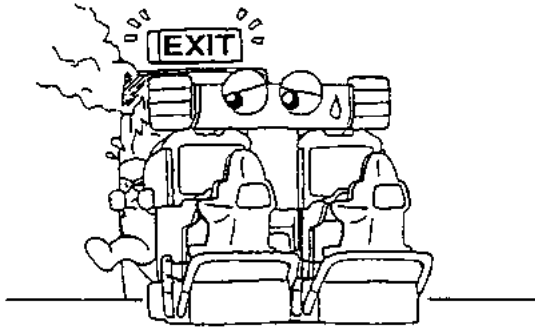

④ Unstable places or places with excessive vibration.

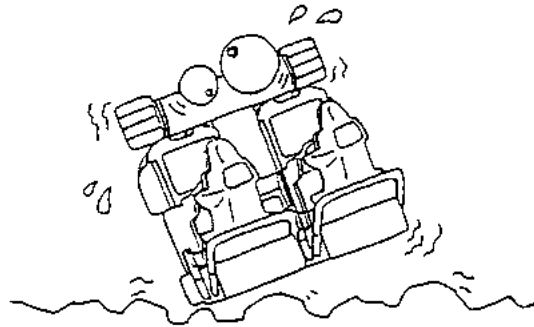

⑤ Places that are not level.

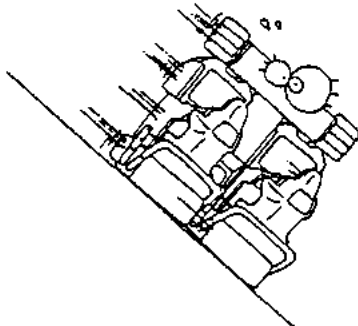

# SAFETY WARNING

## In Order to Use This Machine Safely

In order to use this machine safely, be sure to read this Installation and Commissioning manual and the Operators Manual carefully before installation and use of the machine.

Whenever the owner of this machine entrusts disassembly, installation, adjustment, routine maintenance or trouble shooting to another person, the owner should ensure that they read the appropriate precautions and relevant sections of this manual before starting work.

**In order that no accidents occur when the machine is in operation, strictly follow the notes on safety described below.**

**Do not turn the machine ON until it has been correctly installed.**

### Warnings for Operation

- NOTE: Only operate this machine after checking that it has been installed correctly in accordance with this Installation and Commissioning manual.
- NOTE: Parts of this machine move during game play, so there are places where the distance between the stationary section and moveable section changes. There are warning stickers to keep hands and feet clear of moving parts, however if the operator feels that a customer playing the game is in any danger, he should warn the customer accordingly.
- NOTE: The warning stickers must always be kept in good condition and replaced if worn so that the customer can read them clearly.
- NOTE: **If there is an error or problem with this machine, operation must be stopped immediately.**

### Warnings for Disassembly, Installation, Routine Maintenance and Troubleshooting

- DANGER: Namco Ltd. bears absolutely no responsibility for accidents or injuries resulting from unauthorized changes to the machine.
- DANGER: Ensure that the machine has been turned **OFF** before making adjustments or carrying out maintenance. Also ensure only qualified personnel carry out maintenance or turn the power **ON** to this machine.
- DANGER: The power supply and inside the monitor will remain hot and have areas of high voltage even though the machine has been turned OFF, and there is a possibility of burns or electric shock. Be careful not to touch these areas.
- DANGER: In order to avoid injuries due to mis-operation, be sure that the voltage of the power supply is within the prescribed limits. Also to prevent possible electric shocks due to failure, this machine **MUST** be fitted with a securely connected earthed plug.
- NOTE: Do not turn the main power switch **ON** until the machine has been installed correctly.

# Contents

<b>1. INSTALLATION .....</b>	<b>7</b>
1-1 Installing the Sign Assembly .....	8
1-2 Installing the Sign Boards (L), (R) .....	9
1-3 Connecting the Seat Assemblies to the Tower Assembly .....	10
1-4 Removing the Shipping Brackets .....	12
1-5 Installing the Guard Fence .....	14
1-6 Applying the Number Stickers .....	15
1-7 Linking Two or More Machines. ....	16
1-7-1 Setting the Link Switches .....	17
<b>2 ADJUSTMENTS .....</b>	<b>18</b>
2-1 Turning on the Power .....	18
2-2 Adjustment Switches .....	18
2-3 Test Mode .....	19
2-3-1 Coin Options .....	20
2-3-2 Game Options .....	21
2-3-3 I/O Test .....	23
2-3-4 Switch Test .....	24
2-3-5 Motor Test .....	25
2-3-6 Motion Stop Test .....	25
2-3-7 Lamp Test .....	26
2-3-8 LED Test .....	26
2-3-9 Sound Test .....	27
2-4 Adjustments When Replacing Parts (Initialization) .....	28
<b>3. DISASSEMBLY .....</b>	<b>29</b>
3-1. Removing the Monitor Assy (L), (R) .....	30
3-2 Disassembling the Upper Seat Assy from the Seat Base Assy .....	31

# 1. INSTALLATION

## Notes on installation

**DANGER:** NEVER turn the power to the machine ON until installation has been completed.

**DANGER:** In order to avoid injury or damage to the machine due to mis-operation, ensure that the voltage of the mains in supply is 220-240volt AC. Also, in order to prevent possible electric shocks, be sure that the machine is connected to the mains in supply with a securely connected earthed plug.

**NOTE:** When installing the machine, in order to maintain customer safety, be sure to attach the supplied rear fence and safety warning mats.

**NOTE:** In order to prevent customer injury when the machine is being played, make sure that the space between the side of the machine and a wall or other machine is at least 30cm.

**NOTE:** In order that the PCB rack or power supply can be removed for service, make sure that the rear of the machine is separated from a wall or other machine by a distance of at least 50cm.

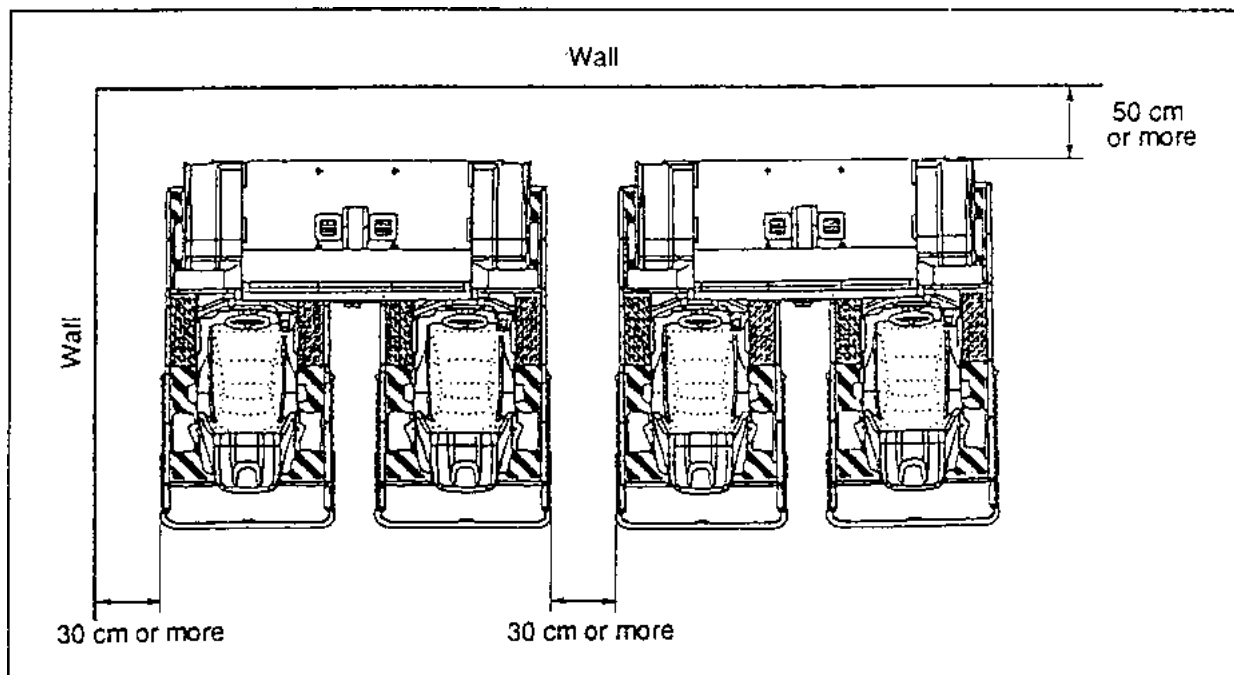

### [NOTE]

The shipping brackets that are removed during installation will be required to be refitted for moving, shipping, and for maintenance when the drive castor is worn. They should be stored safely and not lost or thrown away.

## 1-1 Installing the Sign Assembly

For your convenience, the sign assembly has already been fitted to the tower unit.

**NOTE:** The weight of the Sign Assembly (not including the sign board) is 32kg. The centre of gravity of the Sign Assembly is to the front, making it unstable, and as assembly involves lifting the Sign Assembly above head height, at least two people should be used to install the Sign Assembly.

- 1) Remove the two security screws (M5x12), and remove the harness cover.
- 2) Make sure that there are no wires or connectors on top of the main tower assy. If there is, drop them in to the tower.
- 3) **NOTE:** The Sign Assembly is unstable. Ensure that one person maintains the balance of the sign assembly during installation.
- 4) Place the Sign Assembly on top of the tower, making sure that the Sign Assembly is forward of the tab at the top rear of the tower. Centre the Sign Assembly left to right and push the assembly back until the base board engages in to the tab.
- 5) Using the four hex head bolts (M10x30) and washers supplied, secure the Sign Assembly to the main tower assembly.
- 6) Feed the harness through from the tower assembly and connect the connectors. Refit the harness cover using the two security screws (M5x12) removed in step 1.

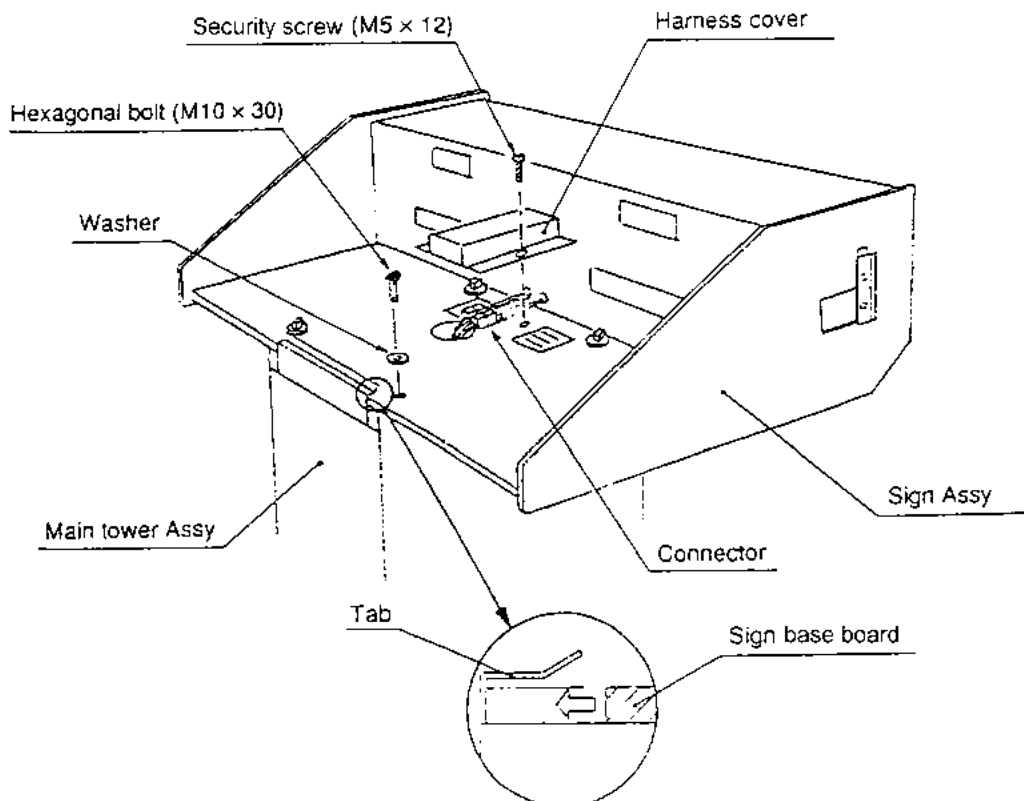

Figure 7.

## 1-2 Installing the Sign Boards (L), (R)

The overall height of the machine can be adjusted by altering the position at which the sign boards are fitted.

Normal Height (Total height: 2,200mm)

- 1) Bring the Sign Boards (L), (R) close to the fixing position, and connect the connectors.
- 2) Hang the Sign Boards (L) (R) on the side joints (L) (R).
- 3) Slide the Sign Boards (L) (R) to the back, and fasten to the cabinet using two security screws (M6x20).

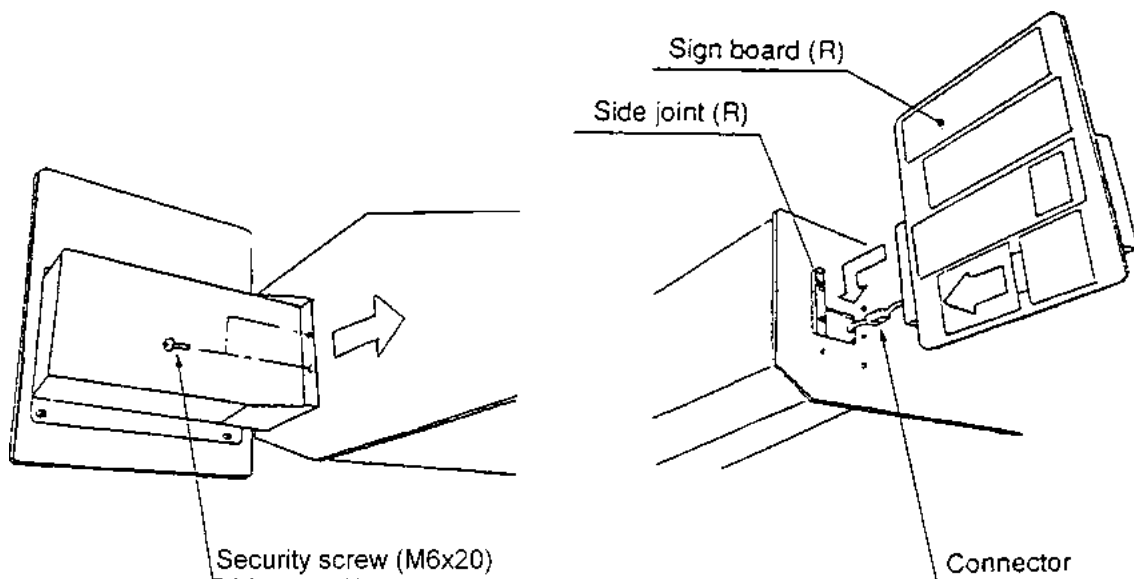

Lower Height (Total height: 2,140mm)

- 1) Remove the two hex head screws (M6x20), and remove the side joints (L) (R).
- 2) Turn the side joint top to bottom, and refit the side joint using the lower two of the three fixing holes.

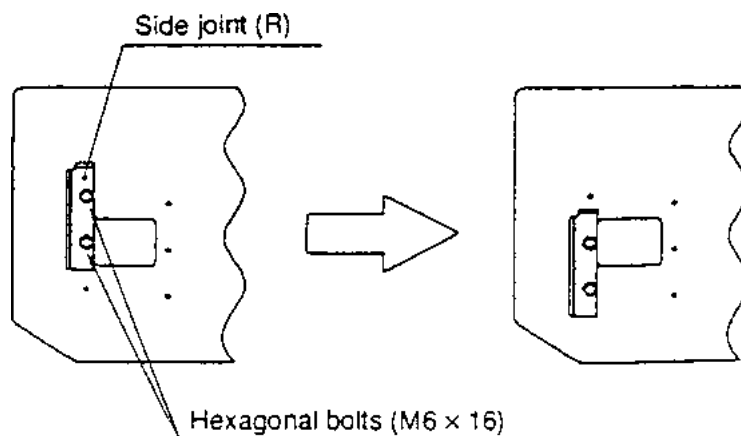

### 1-3 Connecting the Seat Assemblies to the Tower Assembly

- 1) Insert the seat assembly from the side of the tower unit so that the front legs of the tower unit are underneath the seat assembly.
- 2) Remove the four security screws (M5x12) from the bottom front of the tower unit, and remove the lower front cover (F). Temporarily fasten the seat unit with two hex head bolts (M10x25), flat washers and safety washers. (Do not tighten)
- 3) Remove the four security screws (M5x12) from the bottom rear of the tower unit, and remove the lower rear cover (S). Temporarily fasten the ride unit with four hex head bolts (M10x25), flat washers and security washers.
- 4) Tighten all of the hex head bolts (M10x25).
- 5) Connect the connectors between the seat assembly and tower unit.
- 6) Connect the other seat assembly in the same way.
- 7) Replace the front and rear covers (F), (S) taking care not to trap or pinch any wiring.

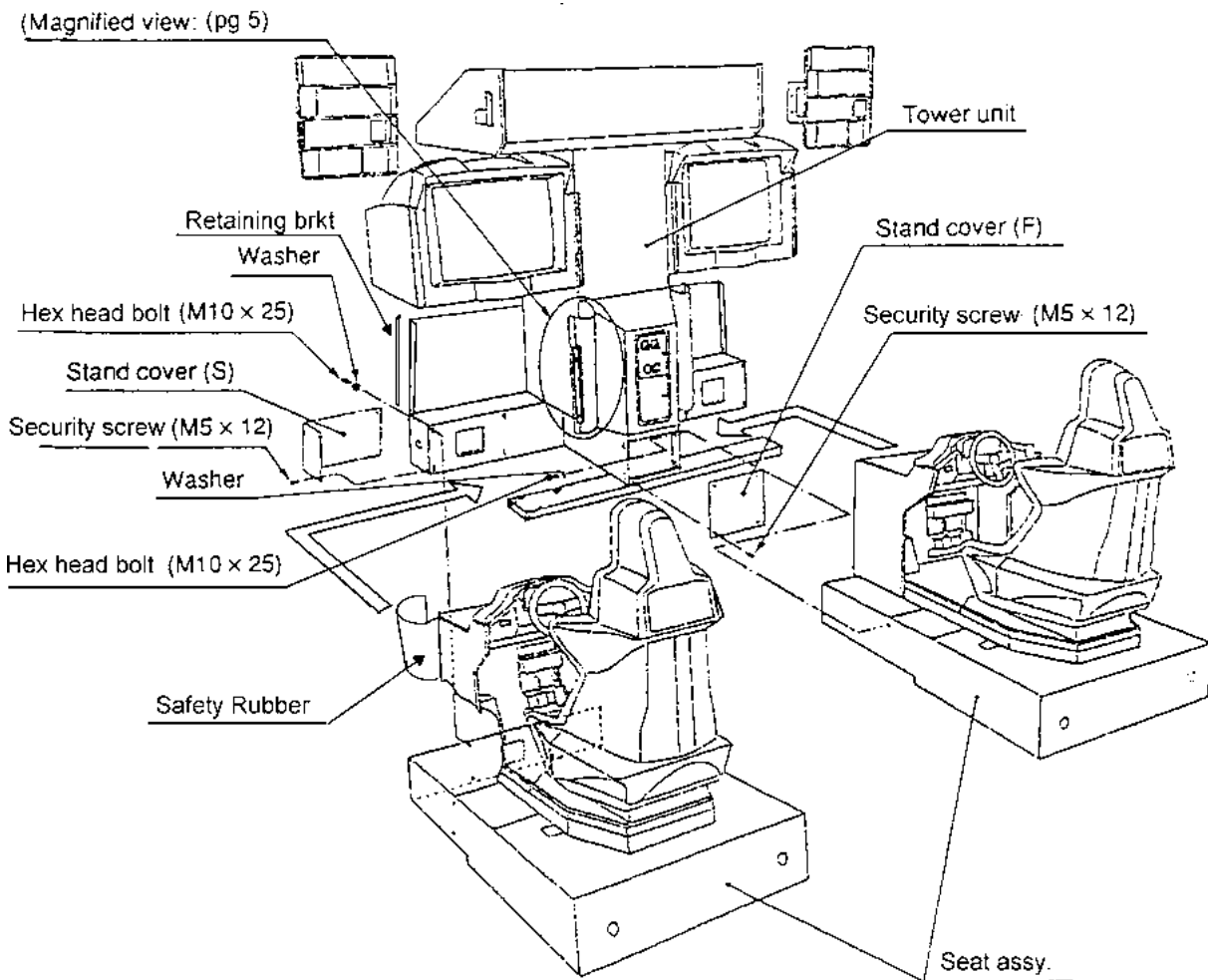

[NOTE]: When connecting the seat assemblies to the tower unit take care not to trap any wires.

- 8) Insert the front rubber brackets (L), (R) of the tower unit in the side panel of the seat assembly, and fasten them with two security screws (M5x16) and two No6X½" pozi flange head screws.

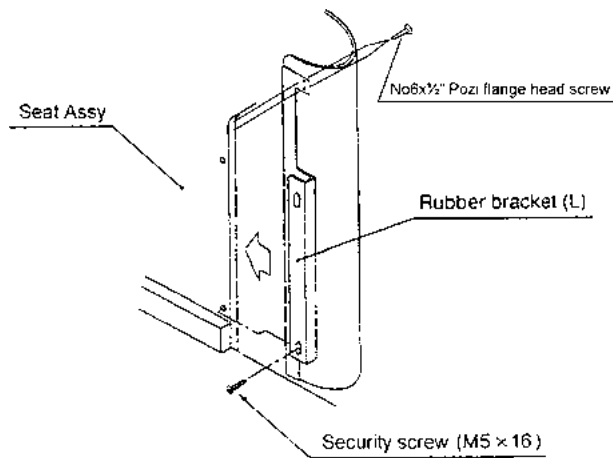

- 9) Remove the five security screws (M5x16) from the tower side support.
- 10) Fit the rear safety rubbers to the tower unit with the retaining bracket and the five security screws (M5x16) previously removed from the tower side support.

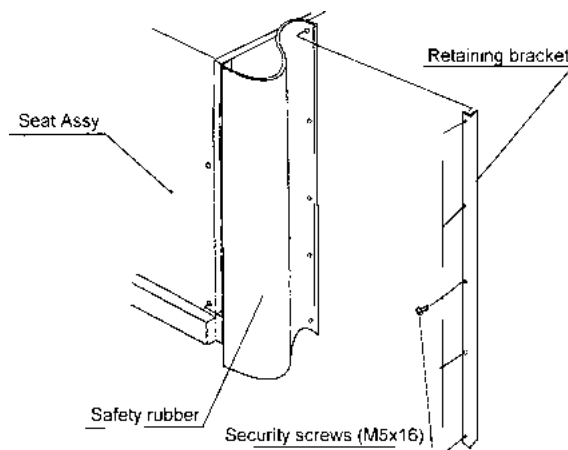

- 11) Place the left, centre, and right safety warning mats in their correct positions.
- 12) When the machine is in its final location, lower the level adjusters (17 adjusters) with a spanner so that all castors are raised from the floor.
- 13) Tighten the lock nuts with a spanner to ensure that the level adjusters not move.

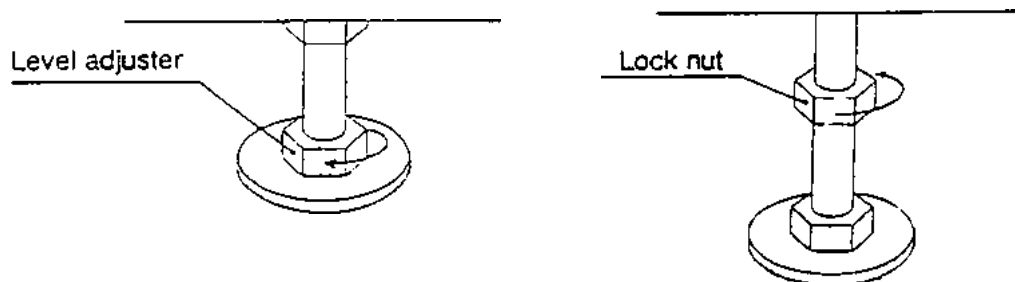

## 1-4 Removing the Shipping Brackets

**NOTE:** Store the removed shipping brackets in a safe place as they must be refitted when replacing the drive castor, when shipping, or when moving the machine.

- 1) Remove two hex head bolts (M8x20) from each rear shipping bracket, and remove the brackets. Retain the four hex head bolts (M8x20) that were used to fit the shipping bracket for future use.
- 2) Slacken two security screws (M10x30), and remove two hex head bolts (M8x20) from each front shipping bracket, and remove the brackets. Re-tighten the four security screws (M10x30).

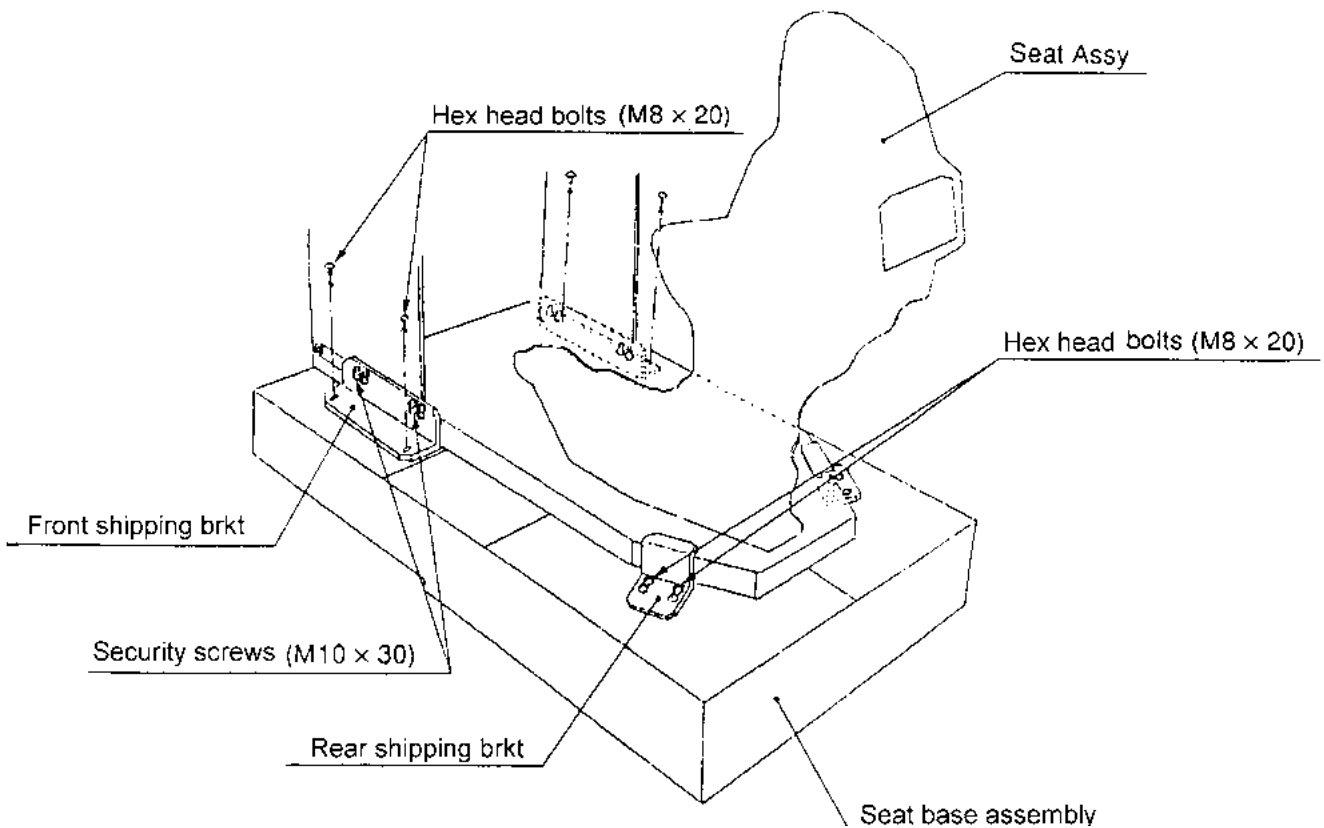

After removing the shipping brackets, install the supplied safety rubber skirt (D) and skirt stay (F) to the upper base assembly as described below.

**NOTE:** The safety rubber skirt is to prevent hands or feet being trapped by the moving parts. **Be sure to install the safety rubber skirts.**

- 1) The safety rubber is installed on the outside of each seat assembly. i.e. on the left of the left hand seat and on the right of the right hand seat.

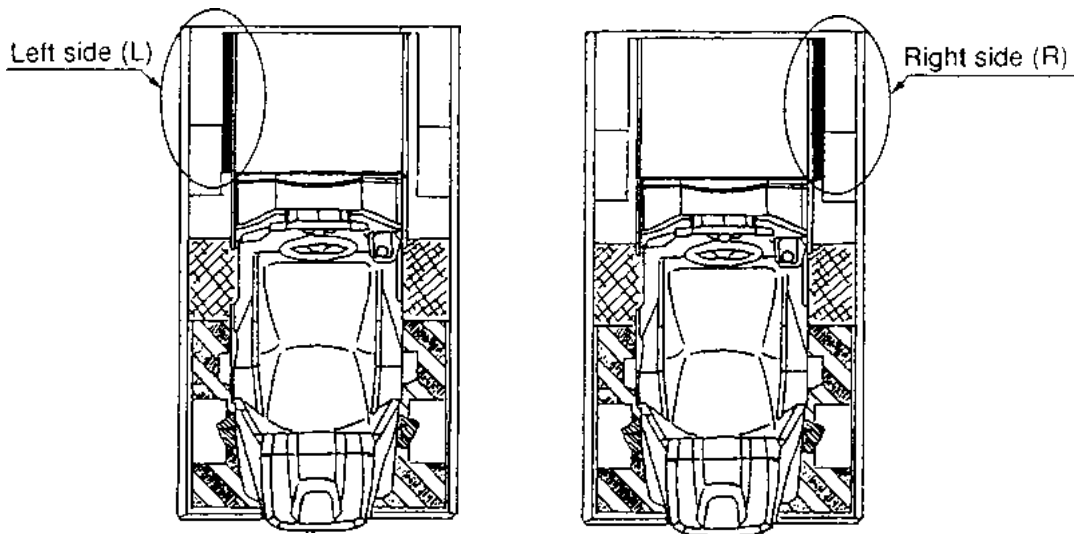

- 2) Install the safety rubber and skirt stay using three security screws (M5x20).

**NOTE:** Ensure that the gap between the bottom of the skirt and the cover plate is no greater than 1.5mm.

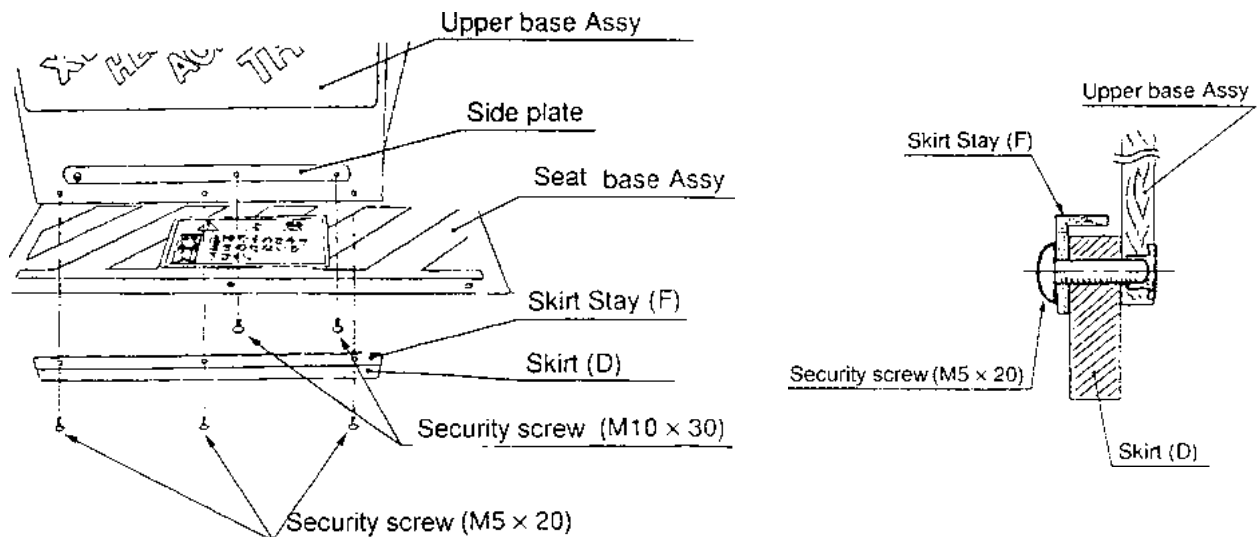

## 1-5 Installing the Guard Fence

- 1) Fasten the guard fence with two retaining plates and security screws (M8x20), flat washers, and security washers.
- 2) Fit the extension brackets (R),(L) to the seat base using six security screws (M8x20), spring washers, and flat washers on each. Ensure that the angles of the extension bracket match the angles of the extensions fitted to the seat bed.

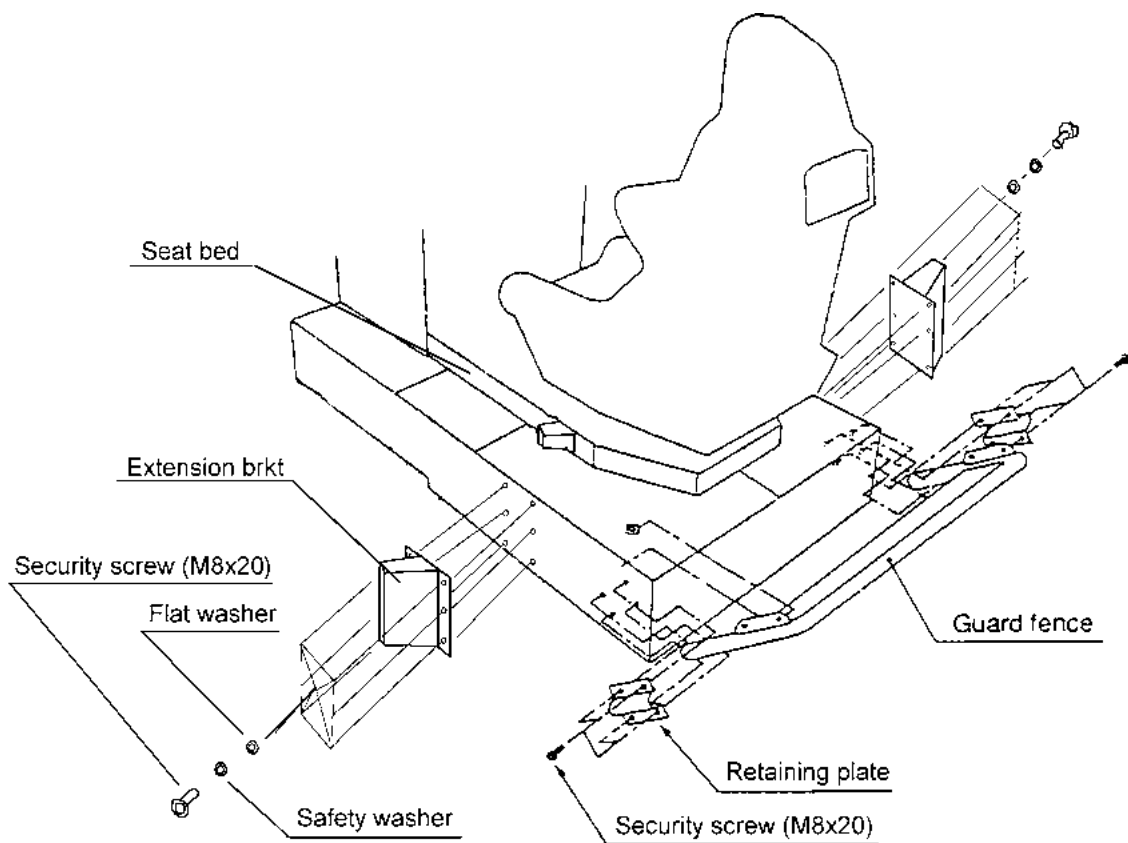

## 1-6 Applying the Number Stickers

Apply the racing number stickers to the seats and sign boards as shown below.

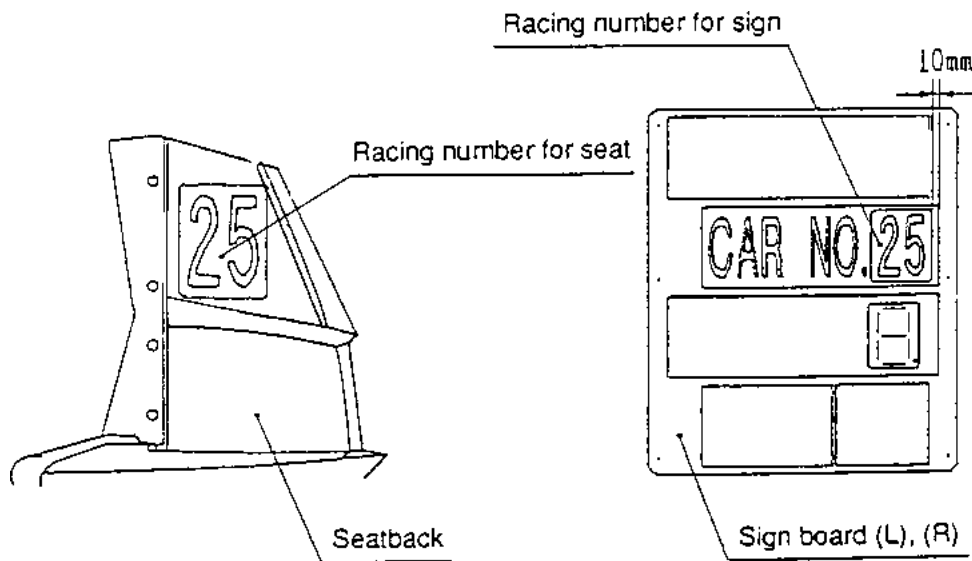

The team colours and car numbers should match those shown in the following table.

TEAM COLOUR	RED 25	BLUE 3	YELLOW 17	GREEN 11	F
Team Colour	Red	Blue	Yellow	Green	
Car Number	25	3	17	11	

[NOTE]: Ensure that the numbers on the screen match the sticker numbers.  
 The "TEAM COLOURS" can be checked in the "Test Mode" - "Setting the Game Options". ([page 14](#))

## 1-7 Linking Two or More Machines.

Up to four machines (8 seats) can be linked together.  
The machines should be linked as described below.

**NOTE: Each machine can draw up to 8 amps. Make sure that the power supply is adequate.**

- 1) Ensure that the power is “OFF”.

- 2) Loosen the two screws (M4x10) on the back of the tower assy, and remove the connector cover.

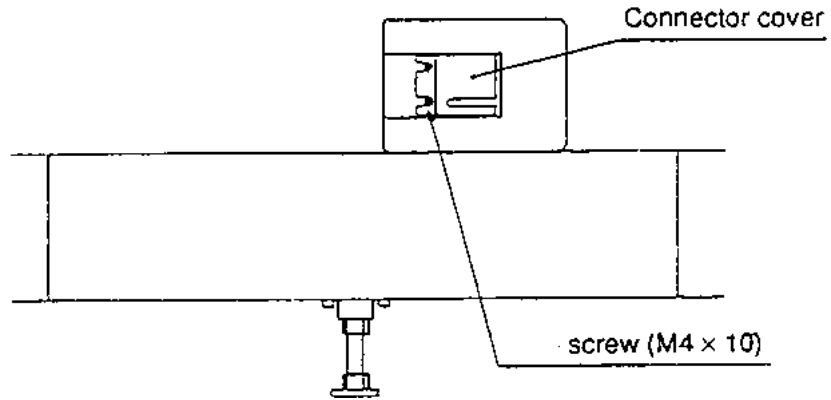

- 3) Set the link switches to “ON”, “EXT”, and “ON”. (See Diag.)

- 4) Use the supplied link cable and connect the machines between “IN” and “OUT” sockets (See Diag.)

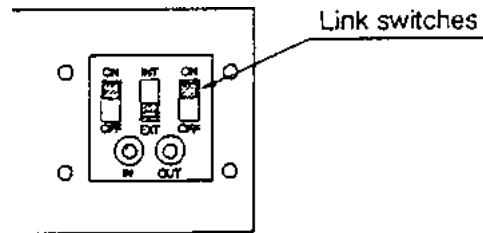

[Examples of Linked Machines]

- a) 2 Machines (4 Seats)

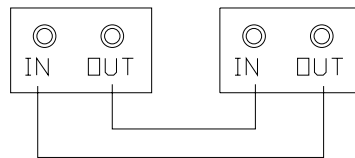

- b) 3 Machines (6 Seats)

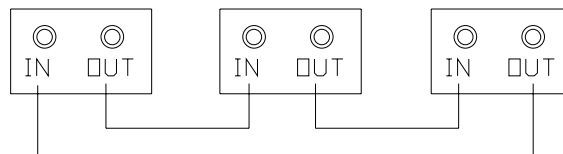

- c) 4 Machines (8 Seats)

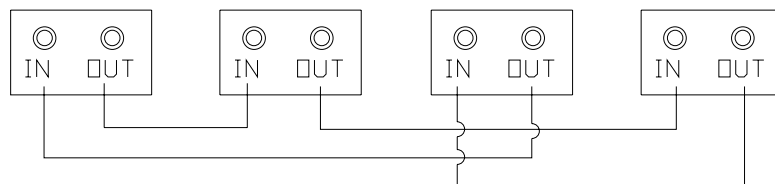

- 5) Turn the power to each machine “ON”, and set the PCB ID using the test mode. (Refer to [“Setting the Game Options”](#)).

Note: Settings other than those described will cause the machine to operate incorrectly.

## 1-7-1 Setting the Link Switches

The link switches are used to set the connection between seats and machines.

- 1) Setting only one machine (2 seats)

Set the link switches to "ON", "INT", and "ON".

*Note: Do not use a link cable.*

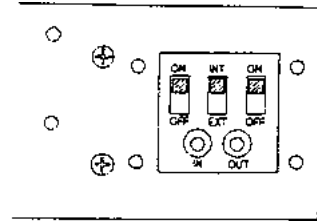

- 2) Setting two or more machines.

Set the link switches to "ON", "EXT", and "ON".

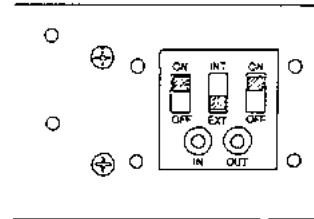

- 3) Install the connector cover using the two screws (M4x10).

The link procedure is now complete.

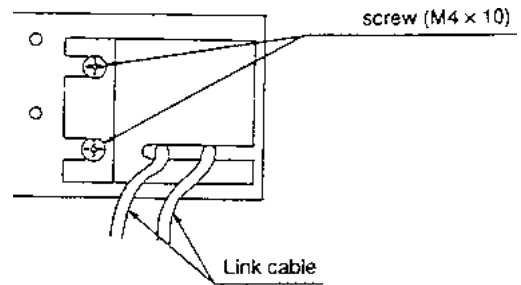

- 4) Setting for faulty PCB.

If the game PCB of only one side is faulty, set the link on that side to "OFF".

[Example of setting for faulty left side]

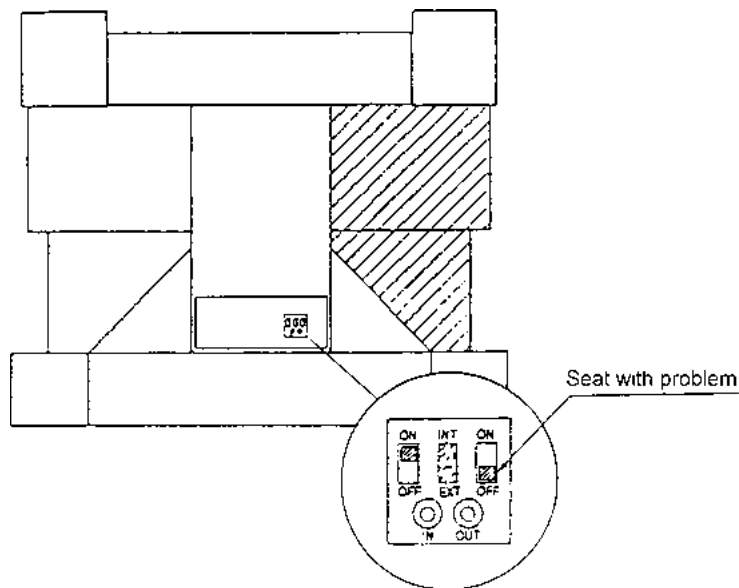

## 2 ADJUSTMENTS

### 2-1 Turning on the Power

After the machine has been correctly installed, turn ON the power.  
The Power switch is located next to the IEC power inlet socket on the rear of the tower unit

### 2-2 Adjustment Switches

The adjustment switches are located inside the coin door.

1. Service Switch  
Press this switch to obtain game credits without incrementing the play meters.
2. Test Switch  
Slide this switch "ON" to enter test mode.  
Test mode allows game testing and the changing of game settings. (Refer to section 2-3 "Test Mode" [\(page 13\).](#))

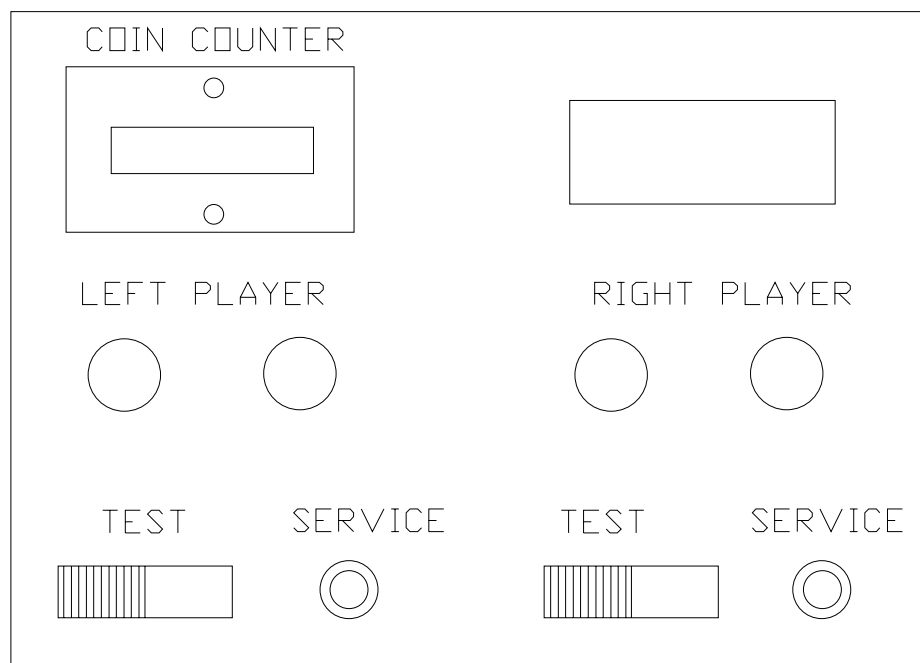

## 2-3 Test Mode

1. Open the coin door and slide the test switch "ON". The "Menu Screen" will be displayed on the monitor.
2. Select the test required by moving the shift lever up or down. The colour of the selected test will change.
3. Enter the selected test by stepping on the accelerator. Select "EXIT" to return to the "Menu Screen" (step on the accelerator when using the monitor test screen).
4. After testing is completed, ensure that the test switch is returned to the "OFF" position to return to game mode.

*The Test Switch must always be in the "OFF" position for normal game mode.*

MENU	
COIN OPTIONS	----- (1) Sets the price of play. ( <a href="#">See 2-3-1</a> )
GAME OPTIONS	----- (2) Sets the game options. ( <a href="#">See 2-3-2</a> )
I/O TEST	----- (3) Used for testing the switches and motor. ----- ( <a href="#">See 2-3-3</a> )
MONITOR TEST	----- (4) Used for adjusting the monitor.
SOUND TEST	----- (5) Used for adjusting the speaker volume. ----- ( <a href="#">See 2-3-9</a> )
ADS DATA	----- (6) Displays the accumulated game data.
OTHERS	----- (7) Used for testing the PC boards and for ----- initializing all of the settings.

GAS: ENTER    SHIFT: CHOOSE

## 2-3-1 Coin Options

- a. Select item (1) "COIN OPTIONS" on the menu screen, to set the game cost and related settings.
- b. Use the shift lever to select the required item then step on the accelerator.
- c. Use the shift lever to change the settings then step on the accelerator to store the new values.
- d. Select "EXIT" to return to the menu screen.

COIN OPTIONS [DEFAULT IN GREEN]		
GAME COST	1 COIN 1 CREDIT	..... (a)
COIN1 MECH VALUE	1 COIN COUNT AS 1 COIN	..... (b)
COIN MECH 2 VALUE	1 COIN COUNT AS 1 COIN	..... (c)
BONUS FOR QUANTITY BUY IN	NONE	..... (d)
FREE PLAY	OFF	..... (e)
EXIT		
GAS: ENTER      SHIFT: CHOOSE		

*Note:- The price of play on this machine is set within the Cashflow Coin Mech. Ensure that the Coin Options on the screen are set as shown in the following table.*

ITEM	CONTENTS	FACTORY SET
(a) Game Cost	Coins required for 1 credit - - - - - settable 1 - 9	1
(b) Coin 1 Mech Value	Number of pulses on meter per coin - - - - - settable 1 - 9	1
(c) Coin 2 Mech Value	Number of pulses on meter per coin - - - - - settable 1 - 9	1
(d) Bonus Coin	Extra coin pulse at specified coins in	NONE
(e) Free Play	Game started by pressing accelerator - - - - - Yes/No	NO

## 2-3-2 Game Options

- a. Select item (2) "GAME OPTIONS" on the menu screen to set the game options.
- b. Use the shift lever to select the required item then step on the accelerator.
- c. Use the shift lever to change the settings then step on the accelerator to store the new values.
- d. Select "EXIT" to return to the menu screen.

*Note: Race Class (c) must be set first before changing items (d), (e), or (f).*

GAME OPTIONS [DEFAULT IN GREEN]				
PCB ID NUMBER				..... (a)
TEAM COLOUR		BLUE 3		..... (b)
RACE CLASS	BEG	EXP	PRO	..... (c)
DIFFICULTY	B	B	B	..... (d)
LAPS [LINK]	3	3	4	..... (e)
LAPS [SOLO]	3	3	4	..... (f)
SPEED DISPLAY			KM/H	..... (g)
SOUND IN ATTRACT			ON	..... (h)
EXIT				
GAS: ENTER		SHIFT: CHOOSE		

### NOTES

- **The rank (level of difficulty) and number of laps must be set the same on all positions that are linked.**
- **The PCB number of the seat furthest left (when facing the front of the machine) should be set to 1, and the other seats set to 2, 3, 4 and so on in order from left to right. The PCB number of the farthest right position should equal the number of positions linked.**
- **Settings other than those described will cause the machine to operate incorrectly.**

ITEM		DESCRIPTION		FACTORY SET
(a) PCB Number		The PCB number should be set so that none of the linked positions have the same number		
(b) Team Colour		RED        25 or 26 BLUE       3 or 4 YELLOW    17 or 18 GREEN      11 or 12  * When more than three sets (6 seats) are linked, different race numbers should be used for the same team colours.		
(c) Race Class	BEG	(d) Game difficulty level (time)	A (long) to D (short)	<b>B</b>
		(e) Number of laps (linked game)	3 to 6	<b>3</b>
		(f) Number of laps (solo play)	3 to 6	<b>3</b>
	EXP	(d) Game difficulty level (time)	A (long) to D (short)	<b>B</b>
		(e) Number of laps (linked game)	3 to 6	<b>3</b>
		(f) Number of laps (solo play)	3 to 6	<b>3</b>
	PRO	(d) Game difficulty level (time)	A (long) to D (short)	<b>B</b>
		(e) Number of laps (linked game)	3 to 6	<b>4</b>
		(f) Number of laps (solo play)	3 to 6	<b>4</b>
(g) Speedo Units		KM/H / MPH		<b>MPH</b>
(h) Attract Sound		ON / OFF		<b>ON</b>

### 2-3-3 I/O Test

1. Select item (3) "I/O TEST" on the menu screen.
2. Use the shift lever to select the required item then step on the accelerator.

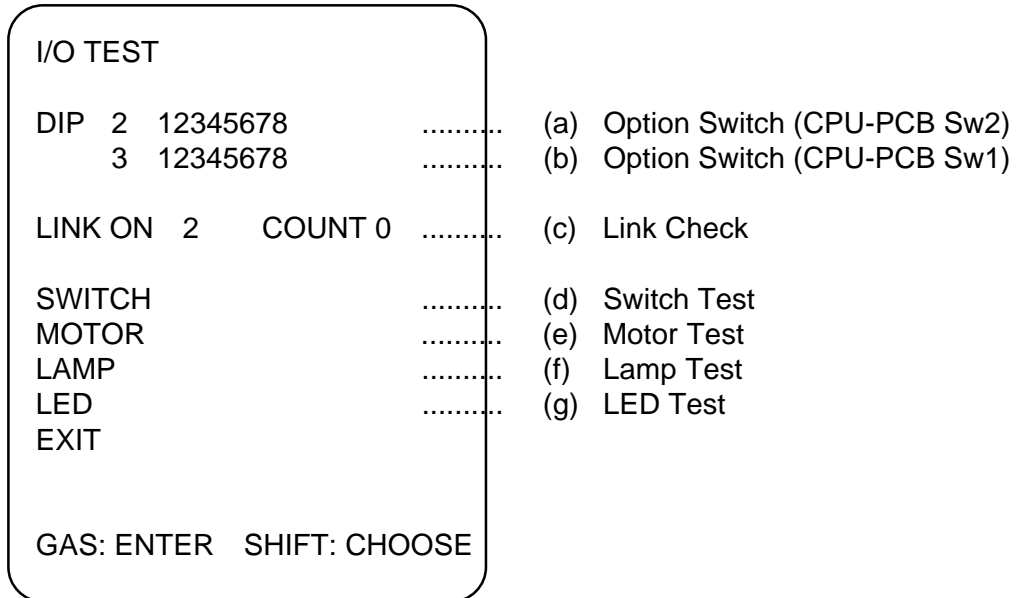

- (a) Displays the state of the option switch, SW2, on the game PC board (CPU-PCB).
- (b) Displays the state of the option switch, SW3, on the game PC board (CPU-PVB).  
For both items (a) and (b), the switch is ON when the numbers are shown in red.
- (c) Displays the number of positions linked. If there is a link error, "ERROR" is displayed. The numbers to the right of "COUNT", display the number of link errors detected during the I/O test.
- (d) Tests the switches. (See 2-3-4.)
- (e) Tests the motors. (See 2-3-5.)
- (f) Tests the lamps. (See 2-3-7.)
- (g) Tests the LEDs. (See 2-3-8.)

## 2-3-4 Switch Test

The following screen is displayed when "SWITCH" is selected on the I/O screen.

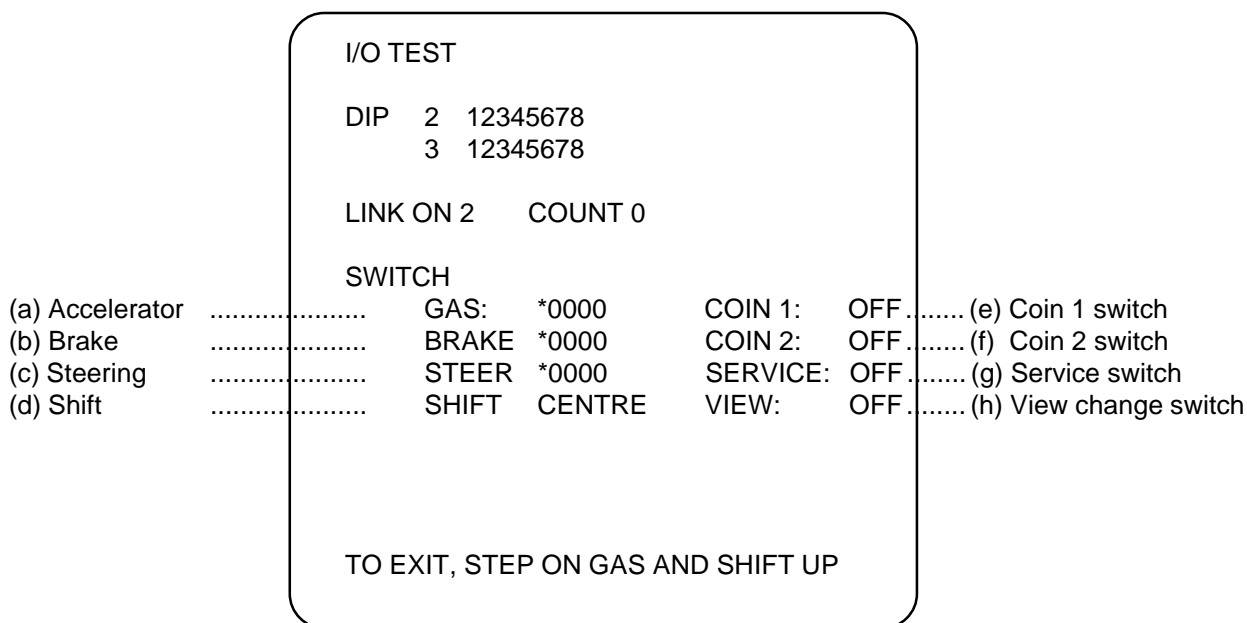

- (a) When the accelerator is stepped on, the number increases in the + direction.
- (b) When the brake is stepped on, the number increases in the + direction.
- (c) When the steering wheel is turned to the right, the number increases in the + direction, and when it is turned to the left, the increases in the - direction.

When items (a), (b), and (c) are in their middle position, "0000" is displayed. (It is normal for the last digit to change.) Just before the steering wheel is as far as it will go, or just before stepping on the accelerator or brake as far as they will go, "OK" will be displayed to the right of the number if everything is correct.

- (d) Displays the position of the shift lever (CENTRE, UP, DOWN) and the state of the switches.

When the shift lever is pressed forward, switch 1 goes "ON" and "DOWN" is displayed, and when it is pulled back, switch 2 goes "ON" and "UP" is displayed.

- (e) When coin 1 switch is operated, "ON" is displayed.
- (f) Unused.
- (g) Goes "ON" when the service switch inside the coin door is pressed.
- (h) Goes "ON" when the view change button is pressed

To return to the menu screen, move the shift lever up and step on the accelerator.

### 2-3-5 Motor Test

The following screen is displayed when “MOTOR” is selected on the I/O screen.

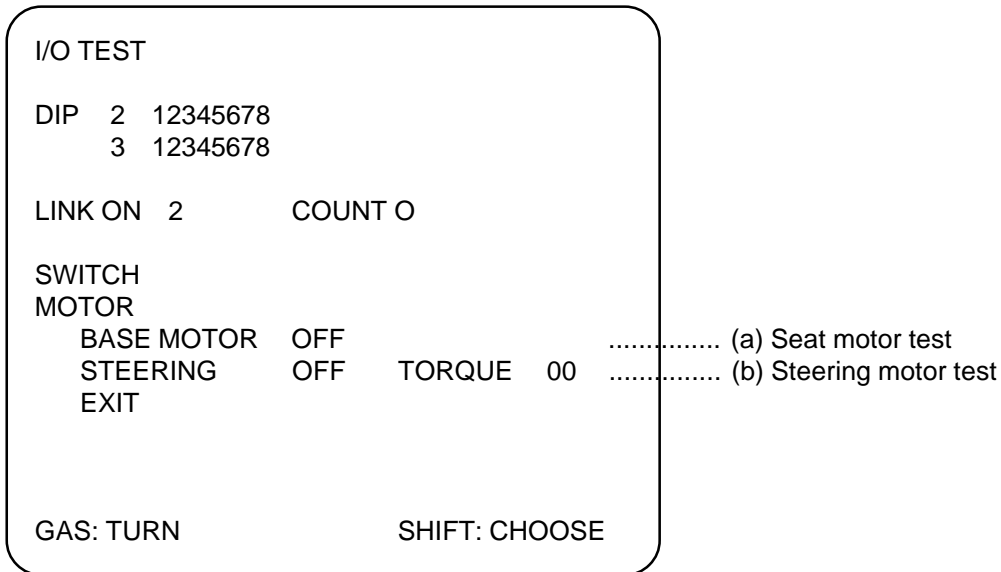

(a) Tests the seat roller motor.

When “BASE MOTOR” is selected and the accelerator is pressed the test is “ON” and the motor starts to operate. Pressing the accelerator again turns the test “OFF” and the motor stops.

(b) Tests the steering feedback motor.

When “STEERING” is selected and the accelerator is pressed the test is “ON” and the motor will start and turn the steering wheel left and right.

When performing this test, ensure that test (a) “BASE MOTOR” is also “ON”.

Pressing the accelerator turns the test “OFF” and the motor will stop.

Select “EXIT” to return to the I/O test screen.

**Note:** Performing the steering motor test can be dangerous, sit on the seat properly, and take hands off the steering wheel.

### 2-3-6 Motion Stop Test

The Stop Motion Switches will illuminate as soon as the test switch is turned ON.

To test the motion stop switches enter motor test ([Refer to section 2-3-5, “Motor Test”](#).) and select Base Motor ON.

Each time a stop motion switch is pressed, the motor will stop and restart when the switch is released.

NOTE: If the switch is pressed during game play, the seat motion will stop and remain off for the duration of that game.



### 2-3-9 Sound Test

To adjust the sound volume, select "SOUND TEST" in the menu screen. The following screen will be displayed.

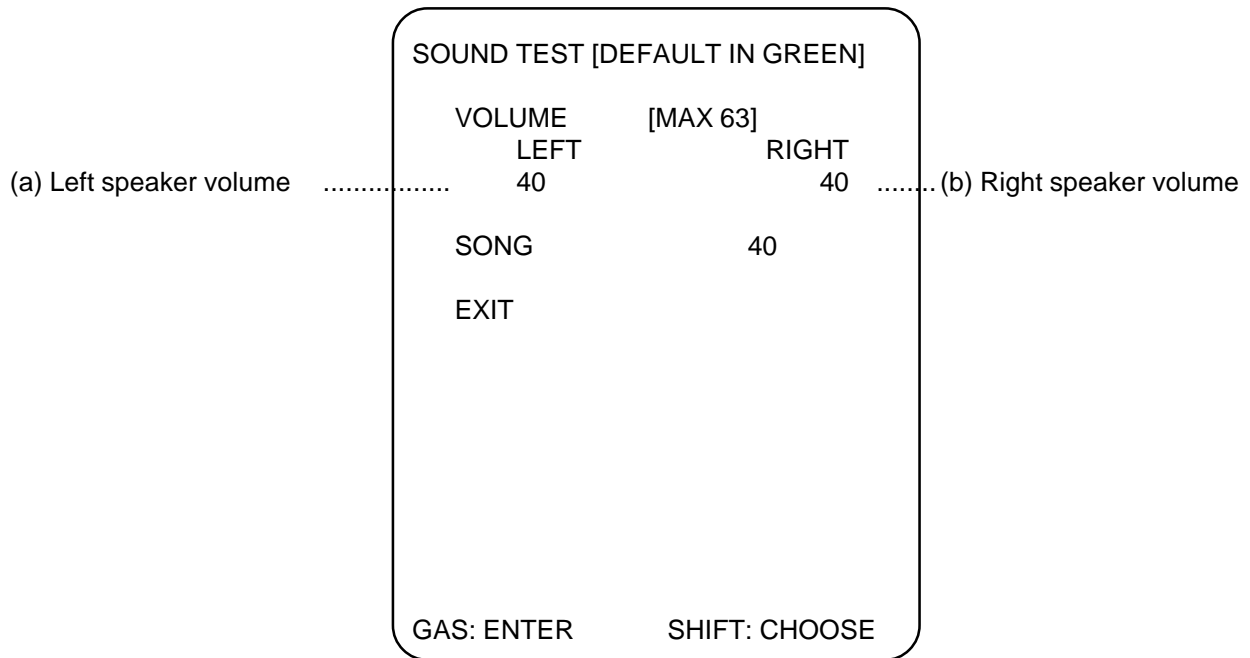

Select (a) or (b) by using the shift lever, the characters will blink in red, when the accelerator is pressed the numbers will start to blink. Moving the shift lever up will increase the number, moving the shift lever down will decrease the number.

The volume can be adjusted in 64 steps, with 00 the lowest and 63 the loudest. The factory setting is "40"

Select "EXIT" to return to the menu screen

## 2-4 Adjustments When Replacing Parts (Initialization)

The following adjustments should always be performed after initial installation and after replacing the game PC board, ROM, Steering Assy, Pedal Assy, or Control Pots. **The game will not operate correctly if these adjustments are not made.**

- a) Ensure that accelerator and brake pedals are fully returned.
- b) Place the steering wheel to it's centre position and remove hands from the wheel  
(*The steering wheel does not return to centre by itself.*)
- c) Slide the test switch "ON" while pressing the service switch. The following screen will be displayed on the monitor.

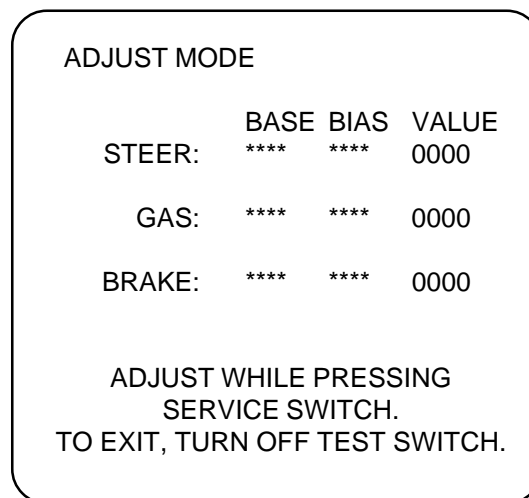

- d) Press the service switch to reset all values to 0000
  - e) Fully depress and release the accelerator, then the brake, then turn the steering wheel fully left and right.
  - f) Slide the test switch "OFF" to return to normal game mode.
- If the above initialization does not perform correctly, repeat two or three times.

### 3. DISASSEMBLY

**NOTE:** The proper number of people (listed in each item) should be used when disassembling.

This machine may be disassembled further than as shipped for shipping and moving. The following is a general method of disassembly.

**NOTE:** Parts may be damaged if placed upside down or on their side when removed.

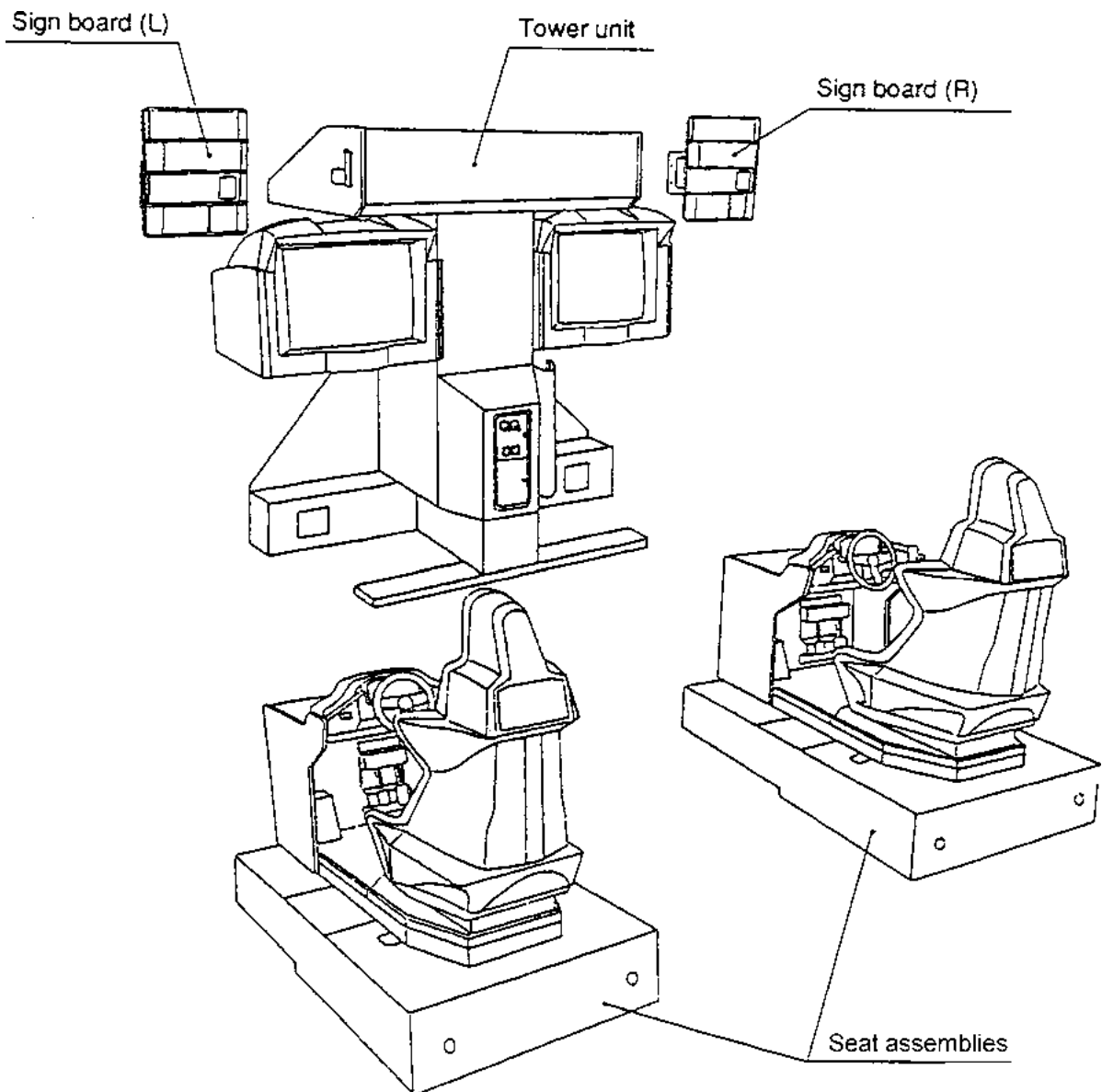

### 3-1. Removing the Monitor Assy (L), (R)

**DANGER:** There are areas within the monitor that have high temperature and very high voltage even after the power has been removed. Extreme care must be taken to avoid burns or electric shock.

**DANGER:** The monitor weighs approx 60kg, at least two people should be used to remove the monitors.

- 1) Ensure that the power is turned OFF before removing the monitors.
- 2) Remove the back door from the monitor.
- 3) Disconnect the six way video connector and three way power connector. Remove the hex head screw (M4x10) retaining the earth terminal.
- 4) Remove the six security screws (M5x12) on the rear of the main tower assy, and remove the rear cover (U).
- 5) Remove the wiring leading from the main tower to the monitor assy.
- 6) Remove the four security screws (M5x12) on the front of the main tower assy, and remove the acrylic fastener bar and acrylic sheet.
- 7) The monitor is fastened on the side and bottom to the main tower assy. Remove the following bolts:  
Side: Five hex head bolts (M8x45), flat and safety washers.  
Bottom: Two hex head bolts (M8x25), flat and safety washers.

**WARNING:** If the seat assemblies are not fitted to the tower and only one monitor is being removed, the tower assembly will be unstable, so remove both monitor assemblies.

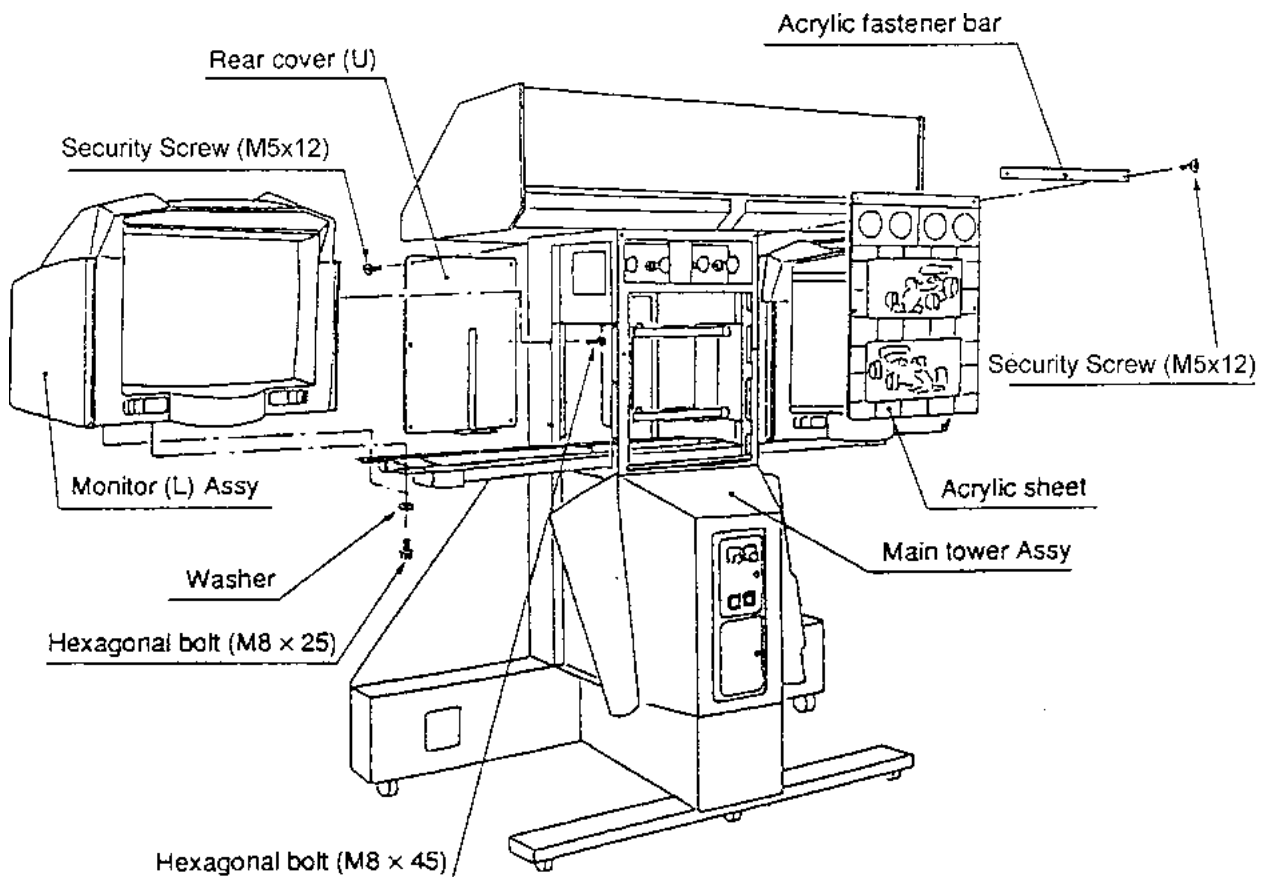

### 3-2 Disassembling the Upper Seat Assy from the Seat Base Assy

**WARNING:** The weight of the upper seat assembly is approx. 120kg. Foot position is poor and the assembly heavy, so at least five people should be used for disassembly

**WARNING:** This work involves moving the seat assembly from left to right in order to remove screws. Take care not to trap or injure the other person when performing this work.

- 1) Remove the rear covers (L), (R).

#### Removing the Rear Cover (L)

- 1) Remove the rear guard fence.
- 2) Turn the steering wheel all the way to the right, and move the cabinet by hand so that the rear cover (L) is easier to remove.
- 3) Remove the security screws (M5x20), and remove the edge guards and rubber skirts.
- 4) Remove the nine security screws (M5x12) and two security screws (M8x20), then remove the rear cover (L)

#### Removing the Rear Cover (R)

- 1) Turn the steering wheel all the way to the left and move the cabinet to the left by hand so that the rear cover (R) is easier to remove.
- 2) Remove the rear cover (R) in the same way as the rear cover (L) as above.

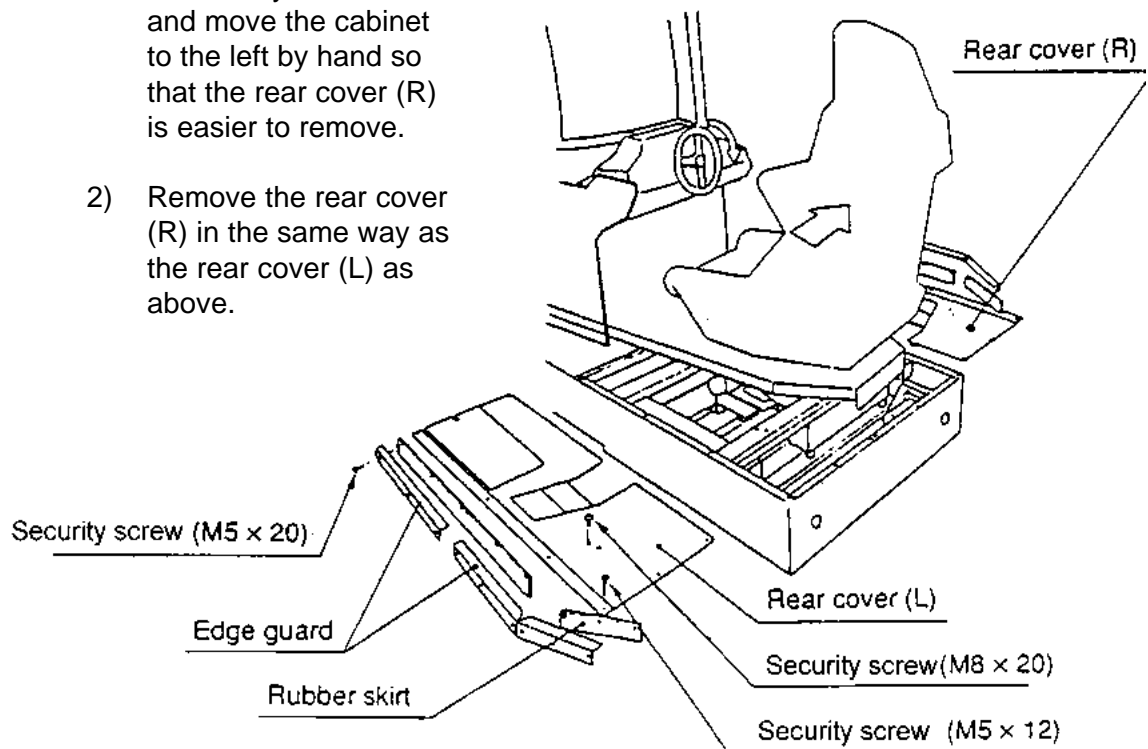

- 1) Remove six security screws (M5x20) and remove the rear cover.
- 2) Remove two security screws (M5x20), four security screws (M5x40), and remove the top cover plate.
- 3) Loosen the hex head screws on the top joint section, slide the sleeve along the shaft and disconnect the joint.
- 4) Disconnect the bottom joint section as follows:
  - a) Remove six security screws (M6x25), and remove the joint cover.
  - b) Remove two hex head bolts (M10x30).
- 5) Slide the upper seat assembly a little to the back, then lift and separate it from the seat base assembly.

