

namco®



Operators Manual

IT IS THE RESPONSIBILITY OF THE OPERATOR TO MAINTAIN CUSTOMER SAFETY
AT ALL TIMES, AND IT IS IMPERATIVE THAT THE DETAILS SET OUT IN THIS
MANUAL ARE FOLLOWED PRECISELY.



No part of this publication may be reproduced by any mechanical, photographic or electronic process, or in the form of phonographic recording, nor may it be stored in a retrieval system, transmitted or otherwise copied for private or public use, without permission from **NAMCO EUROPE LIMITED**.

While the information contained in this manual is given in good faith and was accurate at the time of printing, NAMCO EUROPE LIMITED reserve the right to make changes and alterations without notice.

This machine has been manufactured in accordance with European Community Directives, and has been tested and complies with the Directives 89/336/EEC and 72/23/EEC by the application of EN55014-1, EN55014-2 and EN60335-1 standards and as such bears the CE marking. Any changes or modifications to this machine must be in accordance with the European Directives. Any unauthorised changes to this product, may contravene such Directives.

Under some conditions of extreme external interference, e.g. radio transmissions, electrostatic discharge or mains borne transients, some degradation of performance may occur. However the machine will recover normal performance once the source of the interference has ceased or been removed.

Following abnormally high surges on the mains supply, the video monitor may need to be manually reset by turning the machine OFF and back ON.

Note:-

If the game processor resets due to an interruption or reduction of the mains voltage any credits established may be lost.

This game is not a machine as defined by the Machinery Directive 89/392/EEC

SAFETY WARNING

In order to use this machine safely, be sure to read this Operators Manual carefully before installation, adjustment or use of this machine.

Whenever the owner of this machine entrusts dis-assembly, installation, adjustment or routine maintenance to another person, the owner should ensure that that person read the appropriate precautions and relevant sections of this manual before starting work.

In order that no accidents occur when the machine is in operation, strictly follow the notes on safety as described below.



This manual along with the Installation Manual (where applicable) form an integral part of the equipment and must be available to the operating and service personnel at all times.

This machine is for indoor use only and should only be used for the purpose intended.









Namco Ltd. bears no responsibility for accidents, injury or damage resulting from unauthorized changes to, or improper use of this machine.

SAFETY NOTES

The following safety notes are used throughout this manual. Familiarize yourself with each of these notes and its meaning before installing, servicing or making adjustments to this machine.

- WARNING**  **Warning denotes a hazard that could result in injury or death. Do not proceed beyond a warning note until the indicated conditions are fully understood and met.**
- CAUTION**  **Caution denotes a hazard that could result in damage to the machine. Do not proceed beyond a warning note until the indicated conditions are fully understood and met.**

GENERAL SAFETY CONSIDERATIONS

-  **Only operate this machine after checking that it has been installed correctly and in accordance with the manual.**
-  **If there is an error or problem with the machine, operation must be stopped immediately and the problem rectified before any further use.**
-  **Installation, service, adjustment or routine maintenance should be carried out by suitably qualified persons only.**
-  **For continued protection against fire hazard, replace fuses with the same type and rating. The use of other fuses or material is prohibited.**
-  **The power supply inside the monitor will remain hot and have areas of high voltage even though the machine has been turned OFF, and there is the possibility of burns or electric shock. Be careful not to touch these areas.**
-  **To prevent possible electric shock due to failure, this machine MUST be fitted with a securely connected EARTHED plug.**
-  **If at any time the mains supply lead becomes damaged, it must be replaced immediately.**
-  **Do not turn the power switch ON until the machine has been installed correctly.**
-  **Before connecting the machine to the mains supply, ensure that the machine is set for the correct voltage and that the correct fuses are fitted.**

NOTES ON INSTALLATION

- ⚠ **NEVER** turn the power to the machine ON until installation has been completed.
- ⚠ In order to prevent possible electric shocks, be sure that the machine is connected to the mains with a securely connected earthed plug.
- ⚠ So that customers are not injured by the movement of the machine, ensure that there is as least 500mm separation between other machines or walls.
- ⓘ In order to avoid damage to the machine due to mis-operation, ensure that the voltage of the mains supply is 230volts AC.

Note: If the location of this machine has a polished floor, it is recommended that rubber pads are fitted under the level adjusters to prevent the machine sliding on the floor.

Note: In order to gain access to the Power Supply and CPU assemblies, make sure that the rear of the machine is separated from a wall or other machine by at least 500mm.

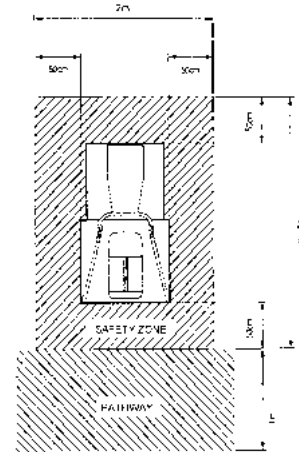

MOVING THE MACHINE

- ⚠ This machine is fitted with castors to make it easier to move. Take care when moving the machine on an inclined surface.
- ⚠ The Header Assembly has a forward centre of gravity, so it is important that at least two people are used to fit or remove the Header Assembly.
- ⚠ The fitting position of the Header Assembly is high, and it is important that a means of reaching the height safely, without stretching, is available. (e.g. Steps, Step Stool etc.)
- ⚠ The overall height of the machine, with the Header Assembly fitted, is 2050mm. Take care of any overhead obstructions. (e.g. Light Fittings, Electric Cables etc.)
- ⚠ When moving the game, ensure that the game is dis-assembled into 3 parts: Monitor Assy, Coin Tower and Header Assy.

REMOVING AND REPLACING PARTS

- ⚠ Adjustments or maintenance on this machine should be carried out by suitably qualified personnel only.
- ⚠ Do not make any alteration to this machine without prior approval. Doing so could cause unforeseeable danger.
- ⚠ Only parts specified by Namco Europe Ltd should be used when replacing or repairing parts. (Including screws).
- ⚠ Ensure that the power to the machine is turned OFF before commencing any maintenance work. (Trouble shooting, repairs etc.)
- ⚠ If performing work not described in this manual, be sure to contact your distributor for instructions, as no responsibility will be accepted for damage or injury.
- ⚠ Parts of the Power Supply and Monitor remain hot and carry high voltage even after switching OFF and could cause burns or electric shock. Take care not to touch these parts accidentally.
- ⚠ Make sure that the machine is switched OFF before connecting or disconnecting any plugs or connectors.
- ⚠ When removing the mains connector from the machine, or the mains plug from the wall outlet, always grasp the plug and not the cable.



Dieses Dokument darf in keiner Weise vervielfältigt werden. Jegliche Tonaufnahmen sowie die Speicherung auf Datenträger (Suchsysteme), die Weitergabe oder sonstiges Kopieren für den gewerblichen und privaten Gebrauch sind untersagt und bedürfen der vorherigen Genehmigung durch NAMCO EUROPE LIMITED.

Die Informationen in diesem Handbuch entsprechen den Tatsachen bei Drucklegung. NAMCO EUROPE LIMITED behält sich jedoch das Recht zu Änderungen ohne vorherige Bekanntgabe vor.

Dieses Gerät trägt das CE-Zeichen und wurde gemäß den EU-Richtlinien produziert. Es erfüllt die Richtlinien 89/336/EEC und 72/23/EEC und Standards EN 55014, EN55104 und EN60335-1 (s. Deckblatt des Handbuches). Alle Veränderungen an diesem Gerät müssen in Übereinstimmung mit den EU-Richtlinien erfolgen. Nicht genehmigte Veränderungen an diesem Gerät verstoßen gegen diese Richtlinien.

Extreme äußere Störungen, wie z.B. durch Radiobetrieb, elektrostatische Entladung oder zeitweilige Netzschwankungen können zu einer Leistungsminderung führen. Sobald diese Faktoren jedoch ausgeschaltet oder beseitigt wurden, erreicht das Gerät seine normale Leistung.

Achtung! Falls der Spielprozessor auf Grund von Netzunterbrechungen oder Abnahme der Netzspannung aussetzt, kann es zum Verlust von Spielkrediten kommen.

Dieses Gerät fällt nicht unter die Maschinen-Richtlinie 89/392/EEC

SICHERHEITSHINWEISE

Um einen ordnungsgemäßen Betrieb dieses Gerätes zu gewährleisten, muß vor Aufstellung, Inbetriebnahme und Gebrauch das Handbuch sorgfältig gelesen werden.

Sobald der Besitzer dieses Gerätes die Demontage, Aufstellung, Inbetriebnahme oder den Service einer anderen Person überträgt, muß er sicherstellen, daß diese Person vor Arbeitsbeginn die nötigen Sicherheitshinweise und die dazugehörigen Kapitel des Handbuches liest und versteht.

Um jegliche Unfälle während des Betriebes zu vermeiden, müssen obige Hinweise strikt befolgt werden.

Dieses Handbuch sowie das spezielle Geräte-Handbuch (wenn vorhanden) gehören zum Gerät und müssen dem Betreiber und Wartungspersonal stets zugänglich sein.

Dieses Gerät ist ausschließlich für den gewerblichen Gebrauch in geschlossenen Räumen bestimmt und darf nur dort betrieben werden.

NAMCO LTD. übernimmt keinerlei Haftung für Unfälle, Verletzungen oder Beschädigungen, die auf nicht genehmigte Veränderungen oder unsachgemäßen Betrieb des Gerätes zurückzuführen sind.











SICHERHEITSHINWEISE

Folgende Sicherheitsbegriffe werden im gesamten Handbuch benutzt. Machen Sie sich daher bitte vor Inbetriebnahme, Wartung und Durchführung von Einstellungen am Gerät mit diesen Warnhinweisen vertraut.

WARNUNG  **WARNUNG bezeichnet eine Gefahrenquelle für Leib und Leben. Erscheint dieser Warnhinweis, darf erst weitergearbeitet werden, wenn die entsprechenden Erklärungen vollständig verstanden und befolgt wurden.**

VORSICHT  **VORSICHT bezeichnet eine Gefahrenquelle für die Beschädigung des Gerätes. Erscheint dieser Warnhinweis, darf erst weitergearbeitet werden, wenn die entsprechenden Erklärungen vollständig verstanden und befolgt wurden.**

ALLGEMEINE SICHERHEITSHINWEISE

-  **Das Gerät darf nur betrieben werden, nachdem es vorschriftsmäßig und in Übereinstimmung mit dem Handbuch aufgestellt wurde.**
-  **Die Warnschilder müssen in gutem Zustand sein und ersetzt werden, wenn sie nicht mehr gut lesbar sind.**
-  **Bei Auftreten eines Fehlers oder Problems muß das Gerät sofort abgeschaltet werden und darf erst nach fachgerechter Behebung des Fehlers wieder in Betrieb genommen werden.**
-  **Aufstellung, Service, Einstellungen und Wartung dürfen nur von dafür qualifiziertem Fachpersonal durchgeführt werden.**
-  **Zur Vermeidung von Feuer, defekte Sicherungen nur durch vorgeschriebene Sicherungen ersetzen. Die Verwendung von andersartigen Sicherungen oder unterschiedlichem Material ist untersagt.**
-  **Das Netzteil im Monitor bleibt nach Ausschalten des Gerätes noch heiß und führt weiterhin Hochspannung. Daher besteht die Gefahr von Verbrennungen und Elektroschlägen. Diese Bereiche dürfen nicht berührt werden.**
-  **Zur Vermeidung von Elektroschlägen muß dieses Gerät mit einem ordnungsgemäß geerdeten Netzstecker versehen sein.**
-  **Bei Beschädigungen des Netzteiles muß dieses umgehend ersetzt werden.**
-  **Gerät erst nach abgeschlossener Aufstellung einschalten.**
-  Vor Einstecken des Netzsteckers bitte sicherstellen, daß Netzspannung und Gerätespannung übereinstimmen, und die vorgeschriebenen Sicherungen verwendet wurden.

HINWEISE ZUR AUFSTELLUNG

- ⚠ **NIEMALS** das Gerät einschalten bevor die Aufstellung völlig abgeschlossen ist.
 - ⚠ Zur Vermeidung von Elektroschlägen muß das Gerät mit einem ordnungsgemäß geerdetem Netzstecker an die Stromversorgung angeschlossen werden.
 - ⚠ Um zu vermeiden, daß Kunden durch die Gerätebewegungen verletzt werden, muß ein Sicherheitsabstand zu anderen Geräten und Wänden von mindestens 50cm eingehalten werden.
 - ⓘ Zur Vermeidung von Beschädigungen durch Fehlbetrieb am Gerät sicherstellen, daß die Netzspannung 230 Volt beträgt.
- Hinweis: Ist das Gerät für einen Aufstellplatz mit glattem Fußboden bestimmt, müssen die Standbeine mit Gummiplättchen unterlegt werden, damit das Gerät fest steht und nicht auf dem Boden hin- und herrutscht.
- Hinweis: Zu Reparaturzwecken am Netzteil und den CPU-Komponenten muß die Rückseite des Gerätes mindestens 50cm von anderen Geräten und der Wand entfernt sein.

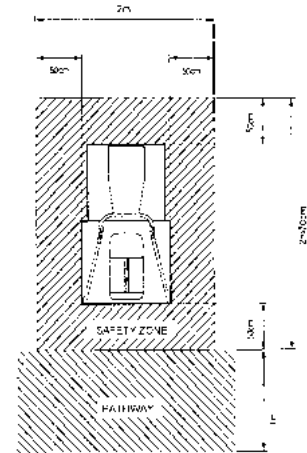

- ⚠ Zum leichteren Transport ist das Gerät mit Rollen ausgerüstet. Daher besondere Vorsicht auf abschüssigem Boden
- ⚠ Der Schwerpunkt des Aufsatzes liegt sehr weit vorn. Daher werden für den Ab- und Aufbau des Aufsatzes mindestens 2 Personen benötigt.
- ⚠ Der Aufsatz wird in großer Höhe montiert. Daher muß aus Sicherheitsgründen eine Steighilfe, wie z. B. eine Leiter, ein Tritt oder ähnliches, verwendet werden.
- ⚠ Die Gesamthöhe de Gerätes beträgt 2.05m. Daher Vorsicht bei tiefer hängenden Beleuchtungskörpern.
- ⚠ Für den Transport oder bei einem Platzwechsel Gerät in drei Teile zerlegen: Kopfteil, Vorderteil, und Fahreinheit

AUS- UND EINBAU VON KOMPONENTEN UND TEILEN

- ⚠ **Aufstellung, Service, Einstellung und Wartung** dürfen nur von dafür qualifiziertem Fachpersonal durchgeführt werden.
- ⚠ Es dürfen keierlei Veränderungen ohne vorherige Genehmigung am Gerät vorgenommen werden. Zuwiderhandlungen stellen eine Gefahrenquelle dar.
- ⚠ Für die Reparatur dürfen nur Originalersatzteile (incl. Schrauben) von NAMCO EUROPE LTD. verwendet werden.
- ⚠ Vor Beginn aller Wartungsarbeiten (Fehlersuche, Reparaturen etc.) muß der Netzstecker gezogen werden.
- ⚠ Bei Arbeiten, die nicht in diesem Handbuch beschrieben werden, muß vorher der Händler zu Rate gezogen werden, da sonst keinerlei Haftung bei Beschädigungen und Verletzungen übernommen wird.
- ⚠ Teile des Netzteiles und Bilschirmes bleiben nach Abschalten noch heiß und führen Hochspannung. Dies kann zu Verbrennungen oder einem Elektroschlag führen. Diese Teile dürfen nicht berührt werden.
- ⚠ Vor der Montage oder dem Entfernen von Steckverbindungen und Steckern muß das Gerät ausgeschaltet werden.
- ⚠ Bei Ziehen des Gerätesteckers oder des Netzsteckers aus der Wandsteckdose stets den Stecker greifen und nicht das Kabel.



Aucun élément de cette publication ne sera reproduit, ni par procédé mécanique, photographique ou électronique, ni par un moyen d'enregistrement phonographique. Ces informations ne seront ni stockées grâce à un procédé de récupération, ni transmises ou autrement copiées pour un usage public ou privé, sans l'autorisation de **NAMCO EUROPE LIMITED**.

Malgré le fait que les informations contenues dans ce manuel soient données de bonne foi et étaient actualisées au moment de leur impression, NAMCO EUROPE LIMITED se réserve le droit de procéder à des changements ou à des modifications sans avis préliminaire.

Ce jeu a été fabriqué en respect des normes de la Communauté Européenne, après avoir été testé il répond aux normes 89/336/EEC et 72/23/EEC, en application des standards EN55014, EN55104 et EN60335-1 (voir la couverture du manuel), et comme tel il comporte l'autocollant de conformité avec les normes de la Communauté Européenne. Tout changement non autorisé sur ce produit pourrait contrevenir à ces normes.

Sous certaines conditions extrêmes d'interférence externe, par exemple des transmissions radio, des décharges électrostatiques ou bien de interférences passagères sur le réseau, certaines dégradations ou anomalies peuvent se produire. Le jeu retrouvera cependant son état normal de fonctionnement lorsque la cause de ces anomalies aura cessé ou se trouvera déplacée.

Note:-

Si le processeur du jeu se reprogramme suite à une interruption ou une réduction de l'alimentation, les crédits qu'il aurait pu contenir peuvent se trouver perdus.

Ce jeu n'est pas une machine, telle que définie par la norme sur les machines 89/392/EEC

MESURES DE SECURITE

Afin d'utiliser ce jeu en toute sécurité, bien lire ce manuel d'utilisation avant de procéder à son installation, son réglage ou son exploitation.

Si le propriétaire de ce jeu en confie la démontage, l'installation, le réglage ou la maintenance habituelle à une autre personne, il devra s'assurer que cette personne ait lu les conseils d'utilisation et les passages du manuel se rapportant à ce thème, avant qu'elle ne commence son travail.

Afin d'éviter tout accident pendant la durée d'exploitation de ce jeu, se conformer strictment aux conseils de sécurité décrits à la suite.

Ce manuel ainsi que le manuel d'installation du jeu (là où nécessaire) font partie des éléments nécessaires à l'installation de la machine et doivent être mis à la disposition de l'utilisateur et du personnel de maintenance à tout moment.

Ce jeu est uniquement destiné à un usage intérieur et devra être utilisé comme tel.

Namco Ltd. ne sera aucunement tenu responsable en cas d'accidents, de blessure ou de dommage quelconque résultant de modifications non autorisées ou d'usage impropre du jeu.











REMARQUES SUR LA SECURITE

Les termes de sécurité détaillés à la suite seront utilisés tout au long de la lecture de ce manuel. Il convient de vous familiariser avec chacun de ces termes ainsi que leur signification avant de procéder à l'installation, à la maintenance ou au réglage du jeu.

AVERTISSEMENT  Ce terme annonce un danger qui pourrait éventuellement avoir des conséquences dommageables ou mortelles. Ne pas passer outre ce signal jusqu'à ce que les conditions indiquées soient entièrement comprises et effectuées.

ATTENTION  Ce terme indique qu'un danger menace la machine. Ne pas passer outre ce signal jusqu'à ce que les conditions indiquées soient entièrement comprises et effectuées.

CONSIGNES GENERALES DE SECURITE

-  **Allumer l'appareil seulement après avoir vérifié qu'il a été correctement installé, et que les instructions du manuel ont été respectées.**
-  **Les notes de mise en garde doivent constamment demeurer en bon état et être remplacées en cas de disparition, afin que le client puisse les lire clairement.**
-  **S'il y a une erreur ou un problème avec la machine, l'utilisation doit être immédiatement interrompue et le problème résolu avant toute nouvelle utilisation.**
-  **L'installation, le service, le réglage, ou la maintenance doivent être effectués uniquement par les personnes qualifiées.**
-  **Afin d'éviter un éventuel incendie, s'assurer que les fusibles soient remplacés par le même type de fusibles et au bon voltage. L'utilisation d'autres sortes de fusibles ou autres matériels est interdite.**
-  **L'alimentation à l'intérieur du moniteur reste chaude et comporte des zones de haute tension même si la machine est éteinte. Il existe donc un risque de brûlure ou d'électrocution. Attention à ne pas toucher ces endroits.**
-  **Pour prévenir une éventuelle électrocution due à un défaut matériel, ce jeu DOIT être muni d'une prise de TERRE connectée en toute sécurité**
-  **Si à tout moment les fils électriques sont endommagés, il faut les remplacer immédiatement**
-  **Ne pas mettre le jeu en mode de fonctionnement avant qu'il n'ait été correctement installé.**
-  Avant de connecter la machine au réseau, s'assurer que la machine est installée sous la bonne tension et que les fusibles correspondent.

NOTES D'INSTALLATION

- ⚠ **NE JAMAIS** mettre le jeu en marche avant que l'installation ne soit complètement effectuée.
 - ⚠ Afin de prévenir une éventuelle électrocution, s'assurer que la machine est connectée au réseau avec une prise de terre reliée selon les normes de sécurité.
 - ⚠ Afin que les clients ne soient pas blessés par les mouvements du jeu, s'assurer qu'il existe au moins 500 mm de séparation avec les autres jeux ou les murs.
 - ⓘ Afin d'éviter que la machine ne soit abîmée suite à une mauvaise opération, s'assurer que la tension sur le réseau principal soit de 230 volts AC.
- Note: Si l'endroit où doit être installée la machine à un sol poli, il est recommandé de poser des tampons feutrés sous les vérins pour éviter que le jeu ne glisse sur le sol
- Note: Afin de faciliter l'accès aux CPU et à l'alimentation, s'assurer qu'il y a un espace d'au moins 500 mm entre l'arrière du meuble et le mur ou tout autre jeu.

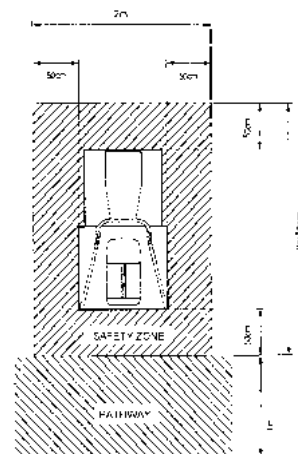

- ⚠ Le jeu est fourni avec des roulettes pour une meilleure mobilité. Prendre garde quand la machine est déplacée sur une surface inclinée.
- ⚠ Le centre de gravité de la partie supérieure du jeu est situé sur l'avant, il est donc indispensable que deux personnes au moins soient employées pour installer ou déplacer la partie supérieure.
- ⚠ L'installation de la partie supérieure du jeu s'effectue en hauteur, il est donc important d'utiliser un élévateur quelconque pour en effectuer le montage.
- ⚠ La hauteur totale de l'assemblage principal est de 2050 mm, prendre garde aux encombrements de la partie supérieure (ex : illuminations du bandeau).
- ⚠ Quand le jeu est déplacé ou transporté, s'assurer qu'il est séparé en 3 parties : l'assemblage du haut (le bandeau), l'assemblage de devant (la cabine), l'assemblage mobile.

DEPLACER ET REMPLACER LES UNITES ET LES PIECES DETACHEES.

- ⚠ L'installation, le service, le réglage, ou la maintenance doivent être effectués uniquement par les personnes qualifiées.
- ⚠ Ne pas apporter de modifications sur cette machine sans autorisation préalable, faute de quoi cela pourrait entraîner un danger.
- ⚠ Seules les pièces détachées Namco Europe Ltd. doivent être utilisées pour le remplacement ou la réparation de pièces (y compris les vis)
- ⚠ S'assurer que l'interrupteur soit sur OFF avant de commencer tout travail de maintenance (localisation d'une panne, réparations, etc.)
- ⚠ Si dans ce manuel il manque une information pour réaliser un quelconque travail, contacter votre distributeur, car aucune responsabilité ne sera acceptée en cas de dommage ou de blessure.
- ⚠ Les pièces de l'alimentation et du moniteur restent chaudes, à tension élevée même lorsque la machine est hors tension, elle pourrait occasionner des brûlures ou des électrocutions. Attention de ne pas toucher ces endroits accidentellement.
- ⚠ S'assurer que la machine soit hors tension avant de brancher ou débrancher toute prise ou connecteur.
- ⚠ Lorsque l'on manipule la prise au réseau de la machine, ou lorsque les prises principales doivent être débranchées, saisir toujours la prise, et non le câble.



GB

THIS MACHINE IS DESIGNED FOR INDOOR USE ONLY.
DO NOT INSTALL THE MACHINE IN THE FOLLOWING PLACES.

D

DIESES GERÄT IST NUR FÜR DIE GEWERBLICHE AUFSTELLUNG IN GESCHLOSSENEN RÄUMEN BESTIMMT. DAS GERÄT DARF AN FOLGENDEN PLÄTZEN NICHT AUFGETSTELLT WERDEN.

F

CETTE MACHINE EST DESTINEE UNIQUEMENT A UN USAGE INTERIEUR.
NE PAS INSTALLER LA MACHINE DANS LES ENDROITS SUIVANTS.

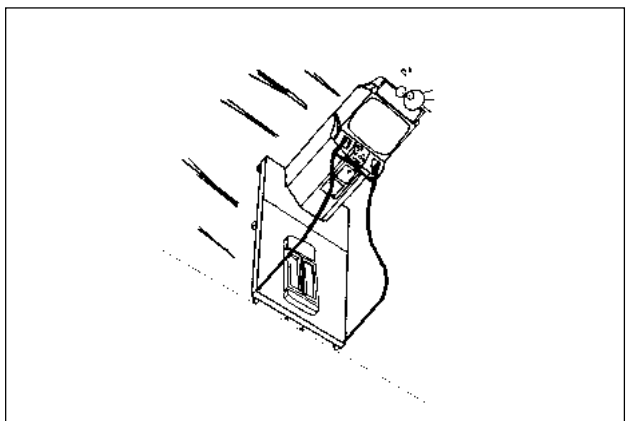
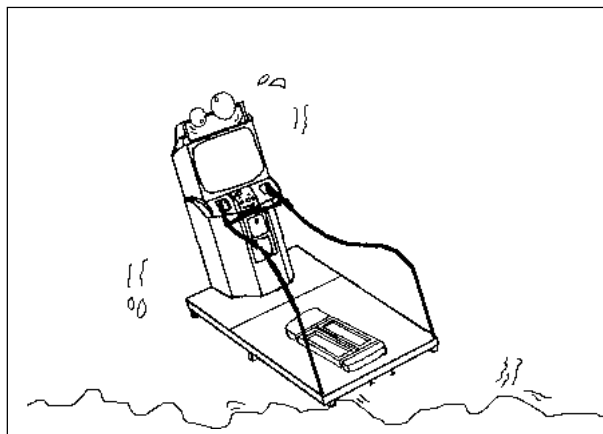
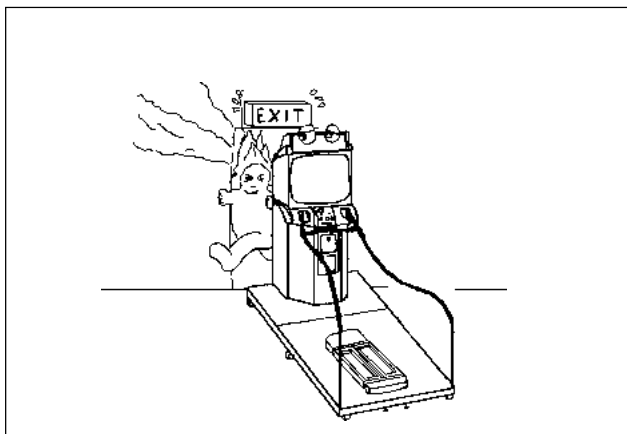
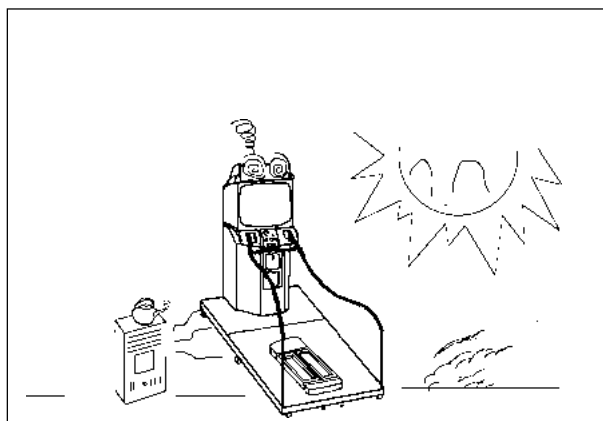
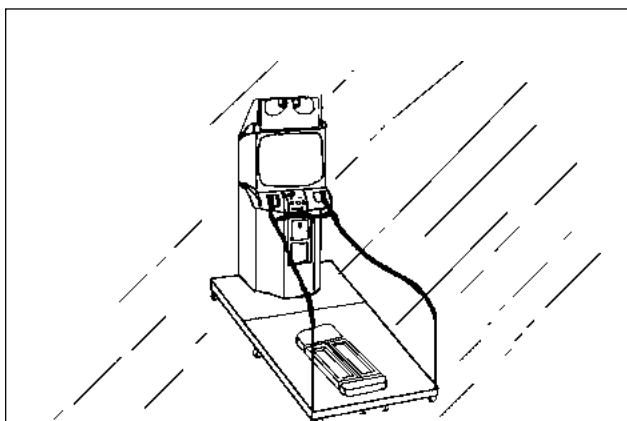

1. SPECIFICATIONS

POWER SUPPLY :-	230volts AC
AMBIENT OPERATING TEMPERATURE:-	+5°C to +25°C
MONITOR :-	Hantarex 28" Polo with Auto Degauss
COIN ACCEPTOR:-	Mars CashFlow - 1 Channel

DIMENSIONS :-

Assembled	970(w) x 1800(d) x 2220(h)
Monitor Assy	970(w) x 910(d) x 1800(h)
Step Assy	970(w) x 890(d) x 1200(h)
Header	660(w) x 375(d) x 420(h)

WEIGHT :-

Assembled	243kg
Monitor Assy	135kg
Step Assy	105kg
Header	3kg

ACCESSORIES :-

Keys:	(Cash Door)	2
	(Coin Door)	2
	(Service Door)	2
	IEC Mains Lead	1
	Operators Manual	1
	Monitor Manual	1
	Cashflow Data	1
	Potentiometer	1
	Link Cable	1
	Joint Bracket.....	2
	M10x25 Hex Head Screw	8
	M10 Spring Washer	8
	M10 Flat Washer	8
	M5 Security Wrench	1

2. HOW TO PLAY

This game is based on Alpine ski racing.

The player stands on the steps and moves them left or right to control the skier. By using the inner edge when moving the steps, the skier slows down and turns quickly.

SINGLE PLAY

- Race Mode

The player races the computer skiers and the object is to cross the goal line first. The game is over when the player crosses the finish line within the given time period, or the time period reaches zero. The time period is increased each time a player passes a check point.

If a player wins in a fast time they can enter their initials. Select letters using the select buttons and enter them by using the decision (Viewpoint) button.

- Time-Trial Mode

The object of the game is to pass between the flags (gates) and to cross the finish line in the fastest time. The rules require the player to go through the gates, so more technique is needed for this mode than the normal race mode.

The game is over when the player crosses the finish line within the given time period, or the time period reaches zero. The time period is increased by one second each time a player passes through a gate.

If a player completes a course in a fast time they can enter their initials. Select letters using the select buttons and enter them by using the decision (Viewpoint) button.

A player is not disqualified for not passing through a gate, however the player will not be able to enter their initials even if they cross the finish line in a good time.

LINKED PLAY

When two games are linked, players on each game will be able to race against each other on the same course. When sufficient credit has been established and the start button has been pressed on one game, there is a time period before the start of the game during which another player can establish credit and press the start button on the other game to enable linked play

- Linked Race Mode

The object of the game is to cross the goal line before the opponent.

The game is over when the player crosses the finish line within the given time period, or the time period reaches zero. The time period is increased each time the leading player passes a check point.

If a player wins in a fast time they can enter their initials. Select letters using the select buttons and enter them by using the decision (Viewpoint) button.

- Linked Time-Trial Mode

The object of the game is to pass between the flags (gates) and to cross the finish line faster than the opponent. No penalty time is given for touching the opposing skier.

The game is over when the player crosses the finish line within the given time period, or the time period reaches zero. The time period is increased by one second each time a player passes through a gate.

If a player completes the course in a fast time, they can enter their initials. Select letters using the select buttons and enter them by using the decision (Viewpoint) button.

A player is not disqualified for not passing through a gate, however the player will not be able to enter their initials even if they cross the finish line in a good time.

GAME SELECTION

- **Skier Selection**
After inserting sufficient credit, the "Skier Selection Mode" will be displayed. The player selects one of three skiers, "Basic", "Mogul" or "Downhill" by using the L/R select buttons and pressing the decision (Viewpoint) button
- **Game Mode Selection**
After the Skier Mode has been selected, the "Game Mode Selection" screen is displayed. The player selects either the "Race Mode" or "Time-Trial Mode" by using the L/R selection buttons, and pressing the decision (Viewpoint) button. Linked Time-Trial Mode is only available if both players select Time-Trial Mode
- **Course Selection**
After the game mode has been selected, the "Course Selection" screen is displayed.
The player can select either the "Hi-Speed Course" or the "Technical Course" by using the L/R selection buttons, and pressing the decision (Viewpoint) button. When in linked mode, the Technical Course is only available if both players select the Technical Course.
- **Viewpoint Selection**
The viewpoint button can be pressed at any time during a game to switch between the views.

Third Persons View: This is the view as seen by a third person. This view can be used to get an understanding of the surrounding conditions. The game normally starts in this view.

Players View: This is the view as seen by the skier. This provides an exciting view while skiing.

Behind View: This is the view from just behind the skier. This view can be used to get an understanding of the skiers posture.

GAME RULES

- **Single Race Mode**
The player races against four computer skiers.
The game will finish when the player crosses the finishing line within the given time period.
The time period is increased each time a checkpoint is reached.
If the time period reaches zero before the player has completed the course, the player will stop, the result will be displayed and the game is over.
- **Linked Race Mode**
The players on two machines will race against each other.
The game will finish when the player crosses the finishing line within the given time period. Both players can finish the course if they have sufficient time.
The time period is increased each time a checkpoint is reached by the leading player and the extra time is added to both players.
If the time period reaches zero before the player has completed the course, the player will stop, the result will be displayed and the game is over.

- **Single Time-Trial Mode**
The object of the game is to pass between the flags (gates) in the fastest time. The game is over when the player crosses the finish line within the given time period, or the time period reaches zero. The time period is increased by one second each time a player passes through a gate.
- **Linked Time Trial Mode**
The game is over when the player crosses the finish line within the given time period, or the time period reaches zero. The time period is increased by one second each time a player passes through a gate.
If the distance between each skier becomes too close, the opponent will disappear from the screen and return when there is a greater distance between the skiers.
The time period is not linked and the one second bonus for passing through a gate is only given to the player passing through the gate, so it is possible for the game to be over sooner for one player than the other.
At game over a three second penalty will be added to a player's finishing time for each gate that the player has missed.
If both players complete the course in the given time, the player with the fastest time, including penalties, is the winner.

3. MAJOR COMPONENTS

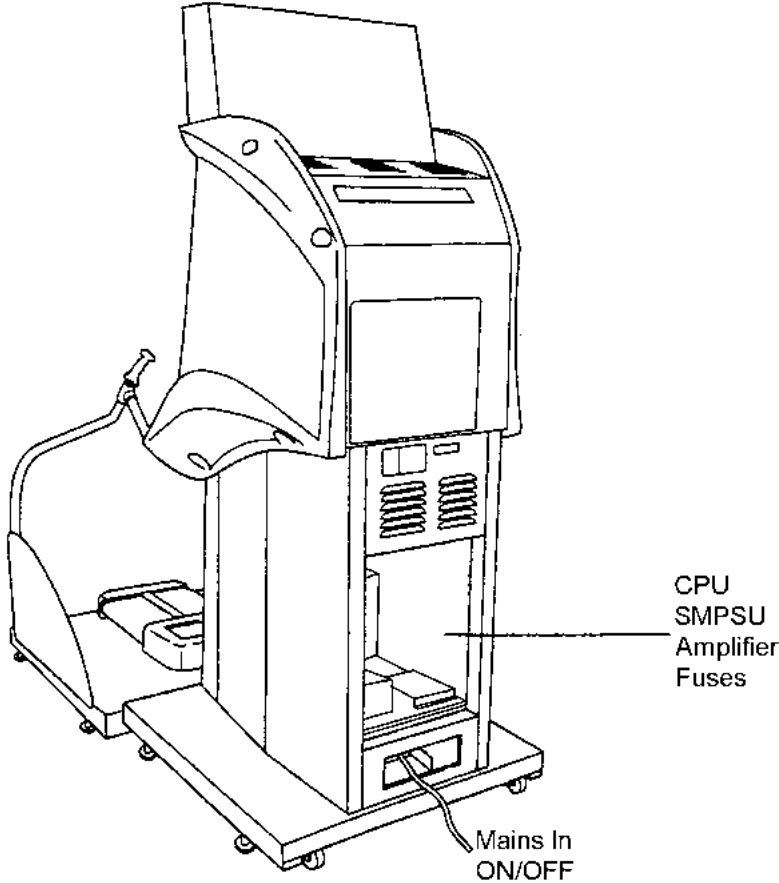
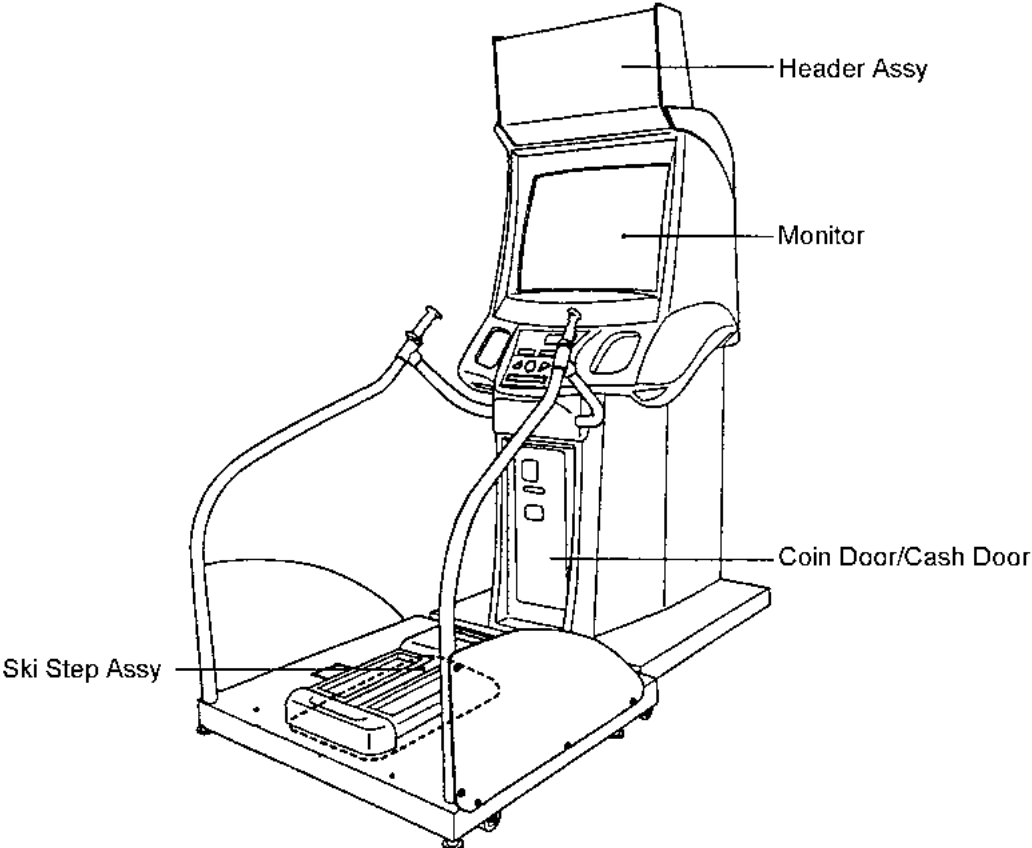

4. MOVING THE MACHINE



WARNING

- This machine is fitted with castors to make it easier to move. Take care when moving the machine on an inclined surface.
- The Header Assembly has a forward centre of gravity, so it is important that at least two people are used to fit or remove the Header Assembly.
- The fitting position of the Header Assembly is high, and it is important that a means of reaching the height safely, without stretching, is available. (e.g. steps, step stool etc.)
- The overall height of the machine, with Header assembly fitted, is 2200mm, take care of any overhead obstructions e.g. light fixtures.



5. INSTALLATION

Notes on Installation



WARNING

- **NEVER** turn the power to the machine **ON** until installation has been completed.
- In order to prevent possible electric shocks, be sure that the machine is connected to the mains with a securely connected earthed plug.
- So that customers are not injured by the movement of the Ski Steps, ensure that there is at least 500mm separation between other machines or walls.



CAUTION

- In order to avoid damage to the machine due to mis-operation, ensure that the voltage of the mains supply is 230volts AC.

NOTE

- If the location site of this machine has a polished floor it is recommended that rubber pads are fitted under the level adjusters to prevent the machine sliding on the floor.
- In order to gain access to the Power Supply and CPU assemblies, make sure that the rear of the machine is separated from a wall or other machine by at least 500mm.
- When installation is complete, it is imperative that the game is initialized. (See [section 6-5 page 21](#))

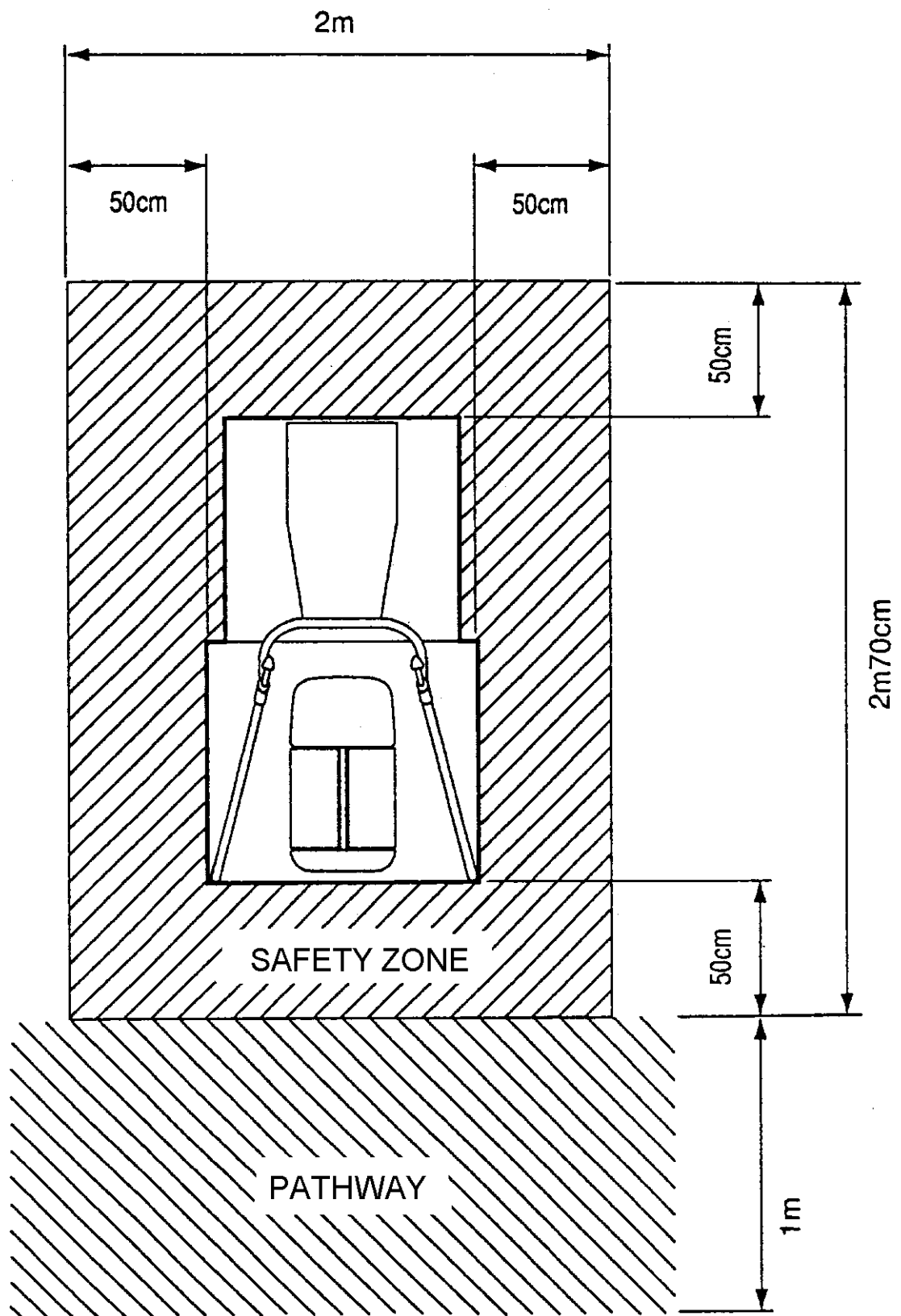



WARNING

This machine is designed for **Indoor Use Only**

Do Not install the machine in the following places.

1. Outdoors

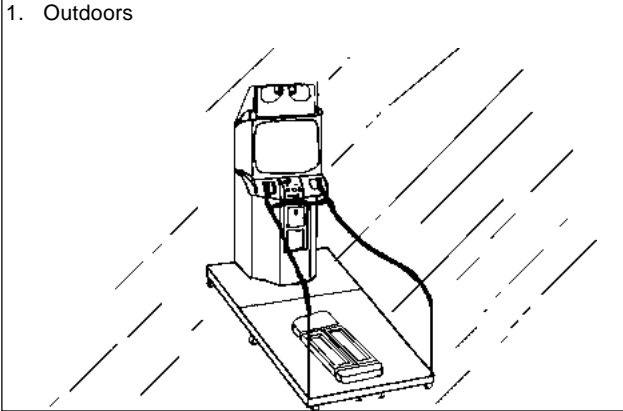

2. Direct sunlight, places with excessive humidity or dust, places where there is water leakage, near air-conditioning or heating equipment, places with excessive heat or cold temperature.

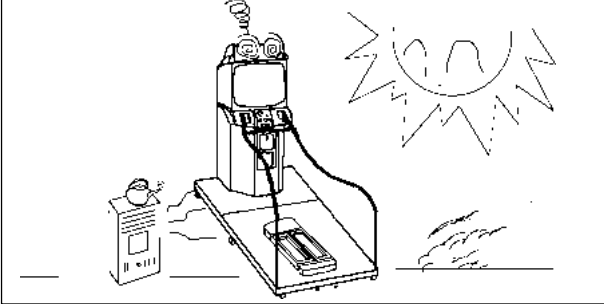

3. Places where it would be in the way of emergency exits or fire extinguishing equipment.

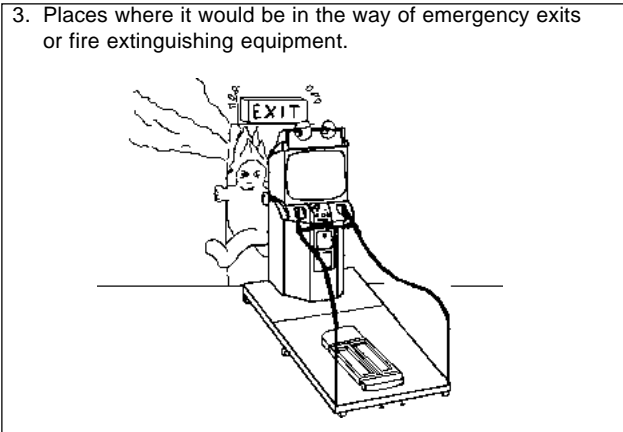

4. Unstable places or places with excessive vibration.

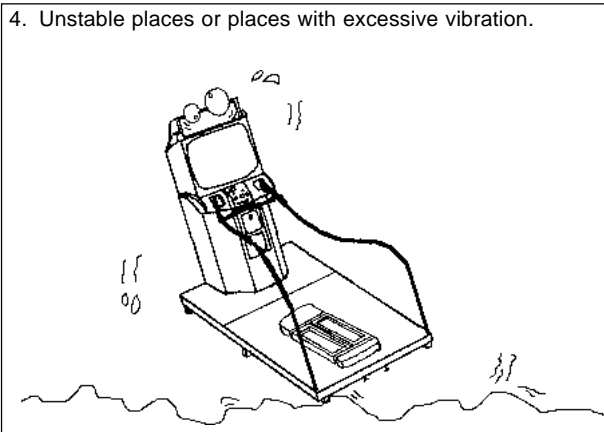

5. Places that are not level.

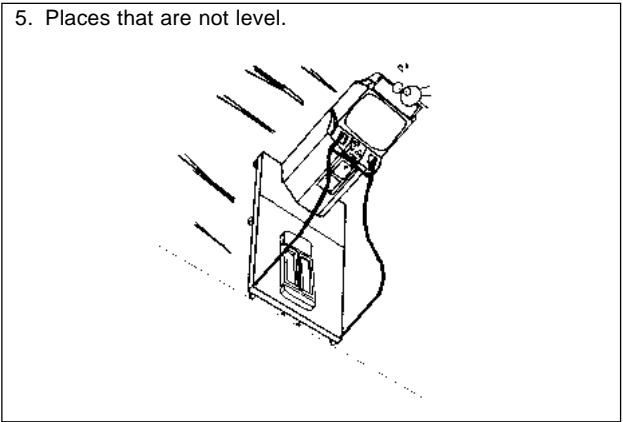

5-1 Assembling the Machine

1. Remove 4 off Security Screws (M5x16) and remove the Clamp Bracket Vac-Form from the front of the monitor cabinet.
2. Remove the 4 off Hex Head Screws (M10x20), Spring Washers and Flat Washers.

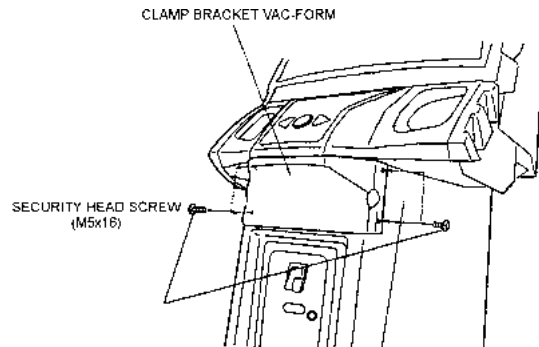

Note: Do not loose the Vac-Form or screws as they are needed for refitting.

3. Remove 4 off Hex Head Screws (M10x20), Spring Washers and Flat Washers and remove the Ski Pole Clamp Bracket from the Shipping Bracket.
Note: Do not loose the Bracket or screws as they are needed for refitting.
4. Remove 2 off Hex Head Screws (M10x20), Spring Washers and Flat Washers

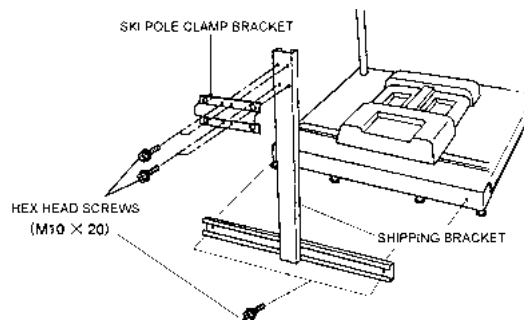

and remove the Shipping Bracket from the Step Base.

5. Connect the 2 connectors between the Step Base and Monitor Base and push the two bases together, taking care not to trap any wires.
6. Fit the Joint Brackets using the 8 off Hex Head Screws (M10x25), Spring Washers and Flat Washers. (4off screws each side)

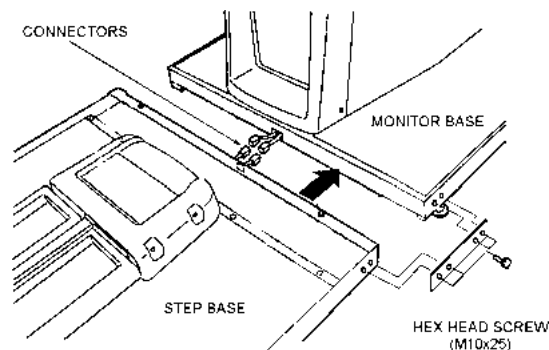

6. Refit the Clamp Bracket using the 8off Hex Head Screws (M10x20), Spring Washers and Flat Washers so that the Ski Pole Joint Bar is clamped securely to the Monitor Cabinet.

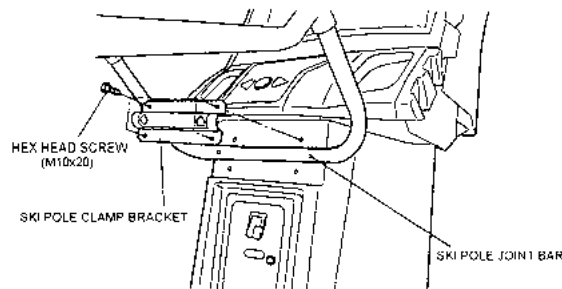

7. Refit the Clamp Bracket Vac-Form using the 4off Security Screws (M5x16)

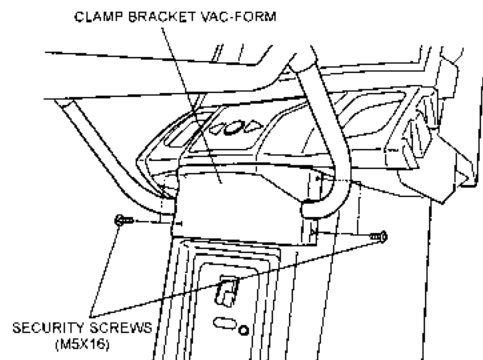

NOTE:-

When the machine is fully assembled and in its final position, lower the 8 level adjusters, with a spanner, so that all castors are raised from the floor by approximately 5mm, and the machine is level. Tighten the lock nuts with a spanner to ensure that the level adjusters do not move.

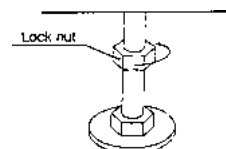
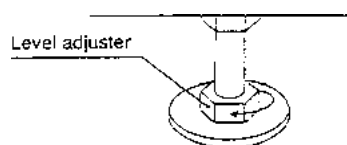

If this machine is installed on a smooth or shiny floor, it is recommended that rubber slip mats be placed under each adjustable foot to prevent the machine from moving when being played.

5-2 Fitting the Header Assembly

The Header Assembly has a forward centre of gravity, so it is important that at least two people are used to fit or remove the Header Assembly.

The fitting position of the Header Assembly is high and it is important that a means of reaching the height safely, without stretching, is available. (e.g. steps, step stools etc)

1. Remove the two security screws (M5x12) and remove the Connector Cover.

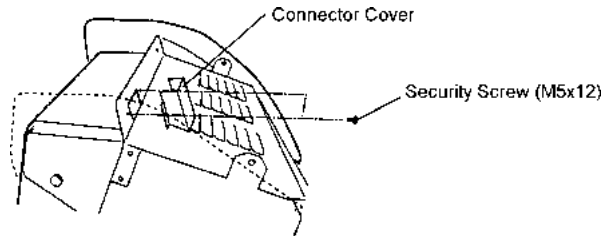

2. Place the Header Assembly on to the monitor cabinet, slide the header back ensuring that it engages fully in to the retaining brackets at the front of the monitor cabinet.

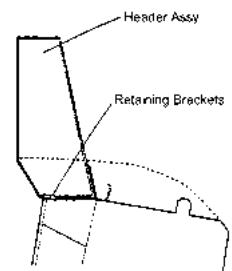

3. Fit the two security head screws (M5x12) to retain the Header Assembly to the cabinet.

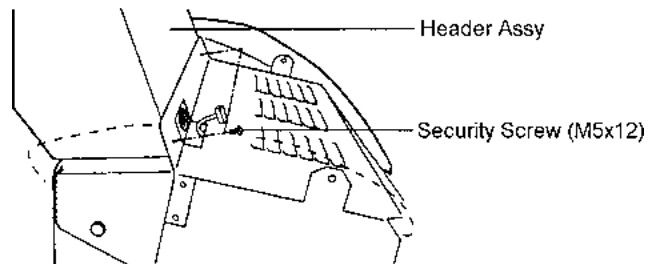

4. Connect the connector and refit the connector cover using the two security screws (M5x12).

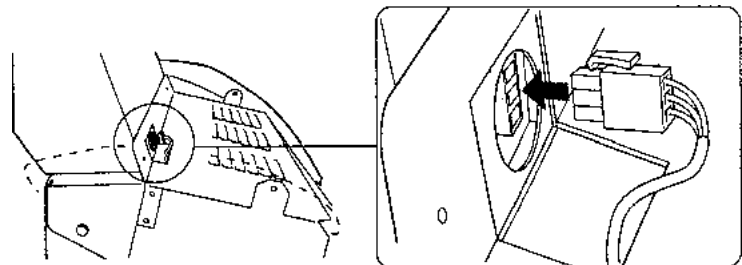

6. ADJUSTMENTS

6-1 Turning on the Power

After the machine has been installed, turn ON the power. The power switch is located on the rear of the monitor cabinet.

6-2 Adjustment Switches

The Adjustment switches are located inside the coin door.

1. Service Switch.
Press this switch to obtain game credits without incrementing the play meter.
2. Test Switch
Slide the test switch ON to enter test mode.
Test mode allows testing and the changing of game settings. (Refer to section [6-3 "Test Mode" \(page 11\)](#))

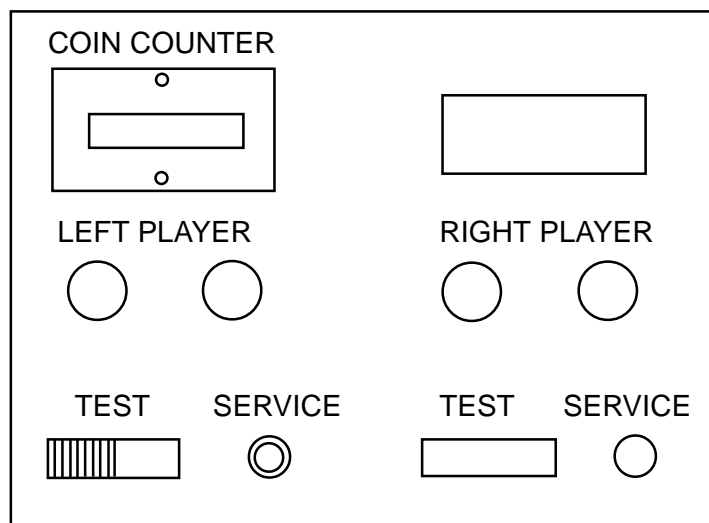

Service Bracket

6-3 Test Mode

1. Open the coin door and slide the test switch "ON". The menu screen will be displayed on the monitor.
2. Select the test required by pressing the 'Left or Right Selection' push button. The selected test will 'blink'.
3. Enter the selected test by pressing the 'Decision' push button. Select "EXIT" to return the "Menu Screen".
4. After testing is completed, ensure that the test switch is returned to the "OFF" position to return to normal game mode.

The Test Switch must always be in the "OFF" position for normal game mode.

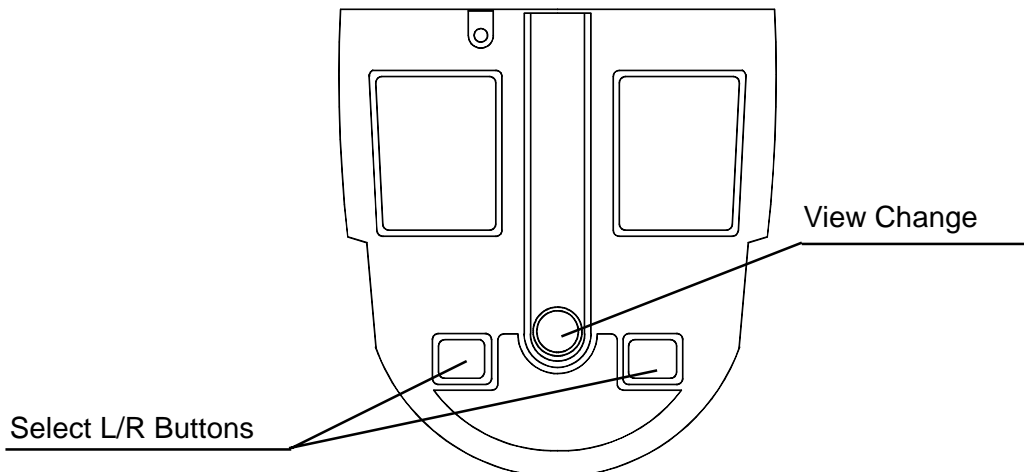
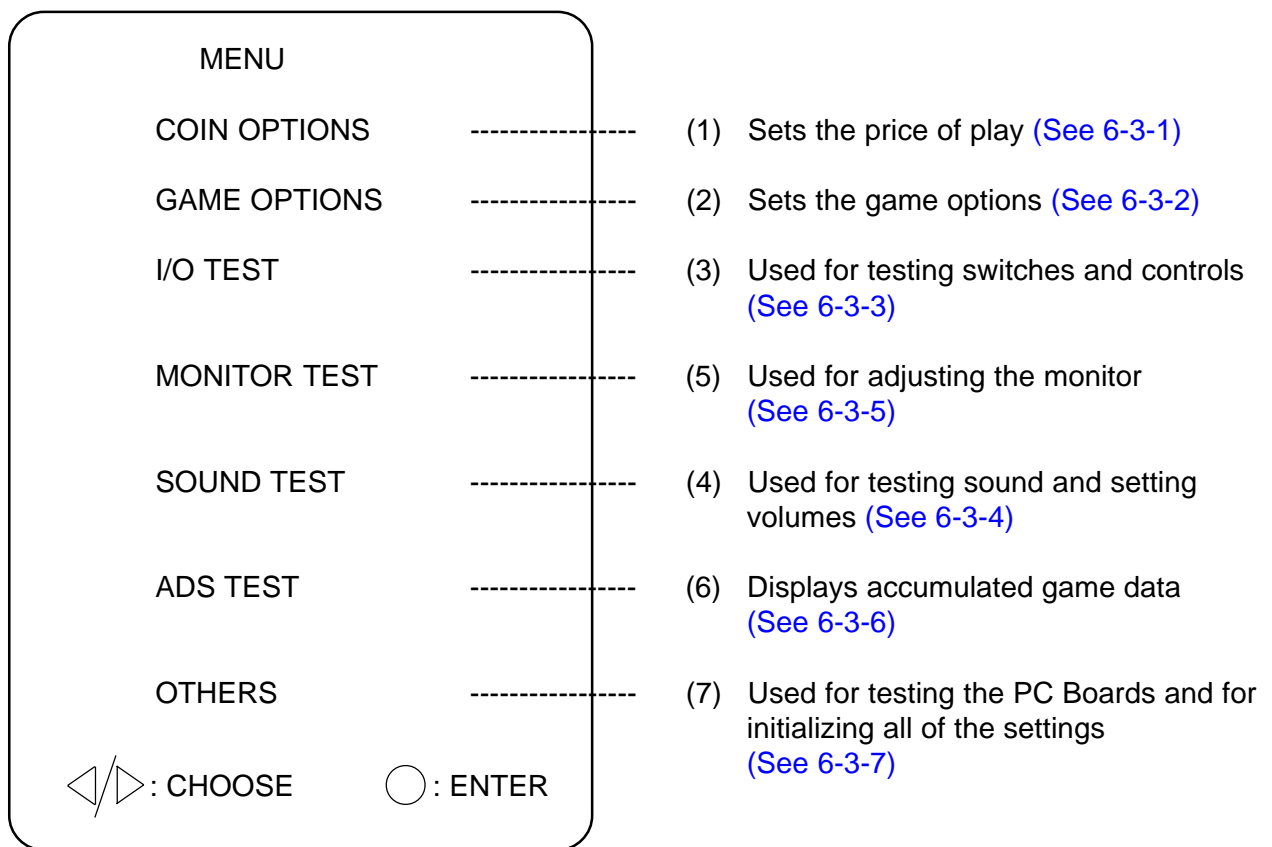

6-3-1 Coin Options

1. Select item (1) "COIN OPTIONS" on the menu screen to set the game cost and related settings.
2. Press 'Select L/R' to select the required item.
3. Use the 'Decision' button to adjust the settings.
4. Select "EXIT" to return to the menu screen.

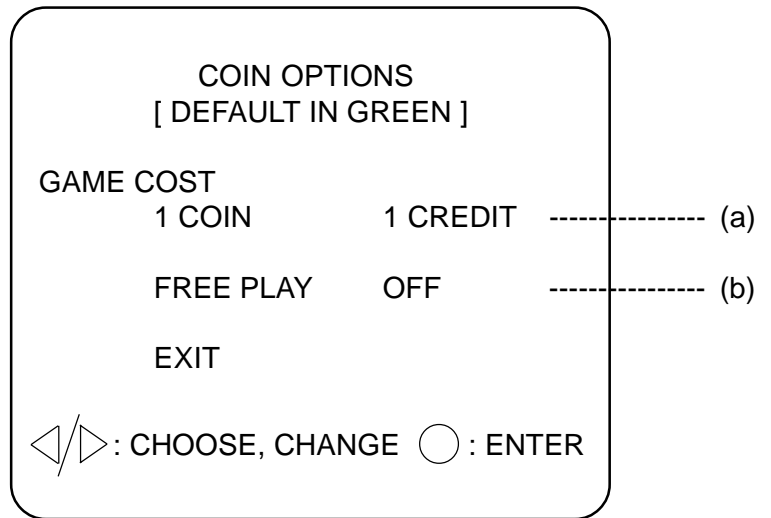

Note :- The price of play on this machine is set within the Cashflow Coin Mech. Ensure that the Coin Options on the screen are set as shown in the following table.

ITEM	CONTENTS	FACTORY SET
(a) Game Cost	No of Coins required for No. of credits - - - - - settable 1 - 9	1 Coin 1 Credit
(b) Free Play	Yes/No	NO

6-3-2 Game Options

1. Select item (2) "GAME OPTIONS" on the menu screen to set the game options and related settings.
2. Press 'Select L/R' to select the required item.
3. Press the 'Decision' button to adjust the settings. Standard settings are displayed in green.
4. Select "EXIT" and press 'Decision' to return to the menu screen.

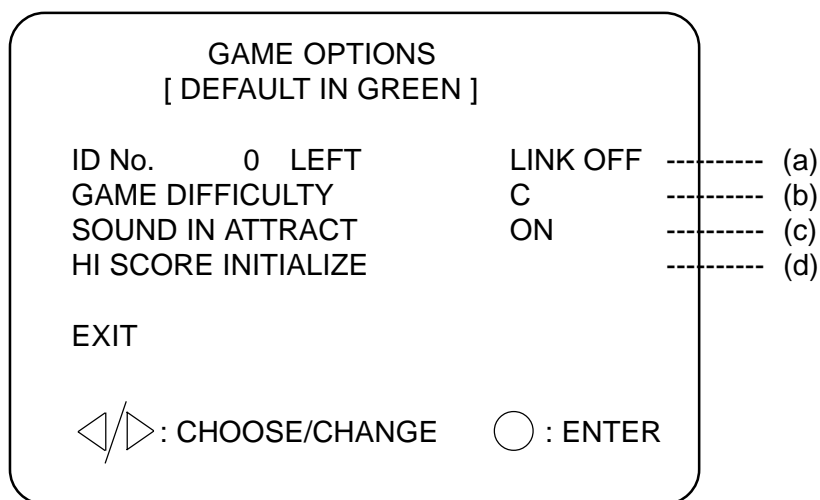

ITEM	DESCRIPTION	FACTORY SET
(a) ID No	Sets machine as left or right when in linked mode	0 Left
(b) Game Difficulty	A (easy) to C (hard)	B
(c) Sound in Attract	On / Off	On
(d) Hi Score Initialize	Yes / No (If Yes Hi Score will be reset when exiting test)	No

6-3-3 I/O Test

1. Select item (3) "I/O Test" on the menu screen to test the switches, motor and step adjust.
2. Press 'Select L/R' to select the required item, then press the 'Decision' button to enter the test.
3. Select "EXIT" and press the 'Decision' button to return to the menu screen.

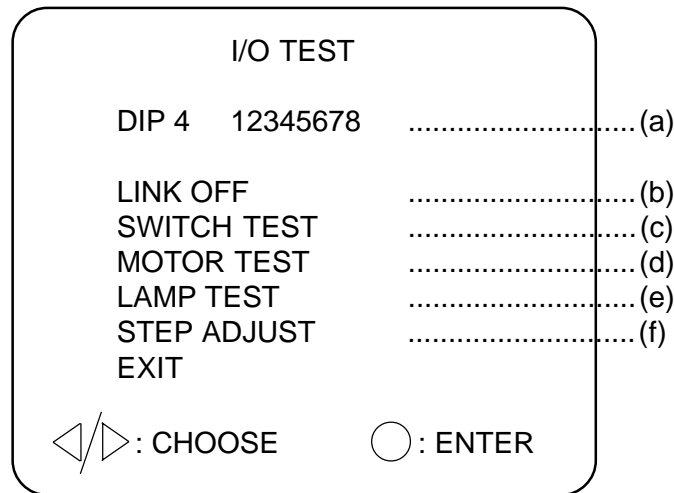

- (a) Shows condition of DIP SW 4 on the PCB. In normal operation all switches are OFF. (If a switch is ON, it will be displayed in red.)
- (b) Displays whether machine is linked. (See 6-4)
- (c) For testing Switches and Control Pots. (See 6-3-3-1)
- (d) Not used on this machine.
- (e) For testing the pushbutton lamps. (See 6-3-3-2)
- (f) For initializing the Step Control Pots. (See 6-3-3-3)

6-3-3-1 Switch Test

1. Select Switch Test from the 'I/O Test' menu. The following screen will appear on the monitor.

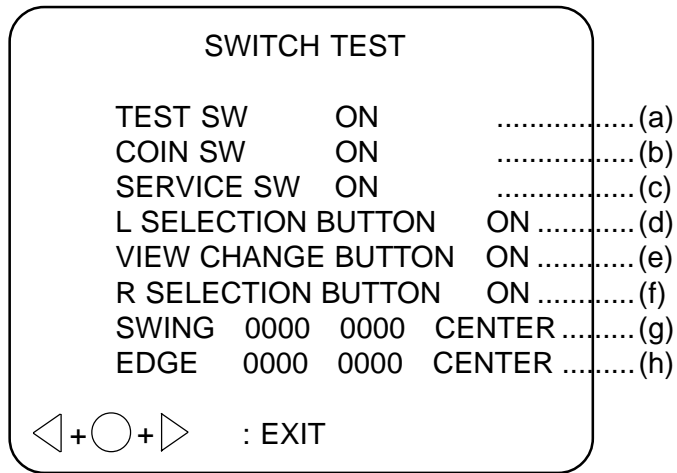

2. The word 'ON' will appear next to items (a) to (f) each time the respective switch is operated.
 When the skis are pushed left, 'SWING-CENTRE' will change to 'LEFT' and 'OK' will appear just before it reaches the extreme left. When the skis are pushed right, 'CENTRE' will change to 'RIGHT' and 'OK' will appear just before it reaches the extreme right. '0000' will increase when the skis are moved to the right and decrease when they are moved to the left.
 When the skis are tilted, 'EDGE-CENTRE' will change to 'LEFT or RIGHT' and 'OK' will appear just before they are fully tilted. '0000' will change as the skis are tilted.

Note: "EDGE" 'OK' will only appear if you stand and apply weight to the edges of the ski steps. There is no problem if 'OK' is not displayed when standing on the steps in the same way as normal play.

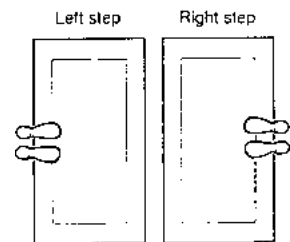

3. If 'OK' is not displayed when the edge is tilted left or right, re-initialize as described in section 6-5 "Initialization After Replacing Parts".
4. Operate both of the 'Select L/R' buttons and 'Decision' button together to exit and return to the 'I/O Test' menu screen.

6-3-3-2 Lamp Test

1. Select Lamp Test from the 'I/O Test' menu.

On entering 'LAMP TEST' the View Change and Select switch lamps will illuminate in sequence and the relevant lamp name will be displayed on the monitor.

6-3-3-3 Step Adjust

1. Select Step Adjust from the 'I/O Test' menu. The following screen will appear on the monitor.

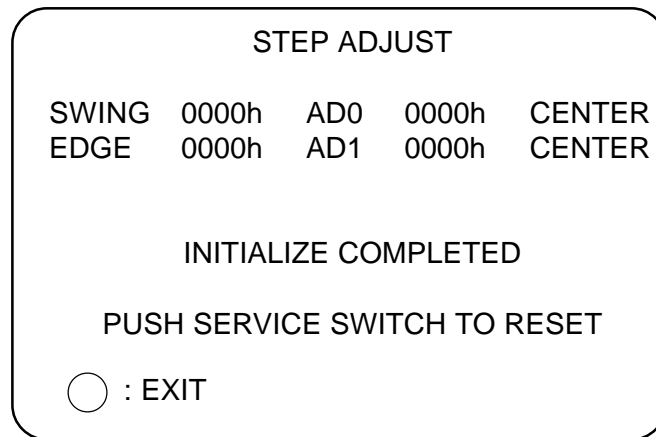

2. Ensure that the skis are in the centre and level, then press the service button. 'INITIALIZE COMPLETE' will appear on the monitor display.
3. Select EXIT to return to the Main Menu Screen.

6-3-4 Sound Test

1. Select item (4) "Sound Test" on the menu screen to test the sound and speakers.
2. The following screen will appear on the monitor.

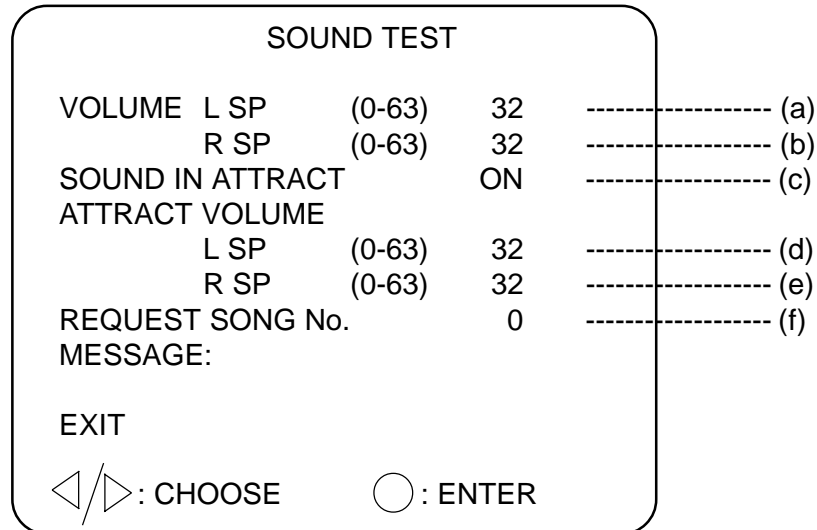

3. Select the required item by 'Select L/R' buttons. The selected item will 'blink'.
4. Pressing the Decision button will cause the selected value setting to blink.
5. Pressing 'Select R' will increase the value and 'Select L' will decrease the value.
6. Press 'Decision' button to return to item select mode.
7. When selecting the 'Request Song No.' test, 'Select R' button will increase the song number and 'Select L' will decrease the number. The 'View Change' button will produce the sound of the song number selected. (Request Song 01 will produce a stereo sound test. Sound will be produced from the speakers in the following order:- Left speaker, Right speaker, Both speakers)
8. Press both Select L/R buttons and View Change button together to return to Sound Test Menu from Request Song No. Test

Item	Description	Factory Set
a	Set left speaker volume ----- 00 Quietest - 63 Loudest	32
b	Set right speaker volume ----- 00 Quietest - 63 Loudest	32
c	Select sound for testing. Each number will produce a different sound. 01 will generate a stereo test.	---

6-3-5 Monitor Test

1. Select item (5) "Monitor Test" on the menu screen to set up and adjust the monitor.
2. On entering monitor test, the screen will display one of the following test patterns.

```

GRADATION PATTERN
CROSSHATCH          GREEN
CROSSHATCH          WHITE
WHITE WINDOW        (H)
WHITE WINDOW        (M)
WHITE WINDOW        (L)
INTERLACE PATTERN
VIEW ANGLE ADJUST (CRT)
VIEW ANGLE ADJUST (PROJECTOR)
FULL WHITE
    
```

3. Use 'Select L/R' buttons to change to the next pattern and 'Decision' button to return to the Main Menu.
4. Refer to monitor manual for monitor adjustments.

6-3-6 ADS Data

1. Select item (6) "ADS Data" on the menu screen to view machine history details.
2. The following screen will appear on the monitor.

ADS 1/2			
	Hrs	Mins	Secs
ON TIME	XX	XX	XX
PLAY TIME	XX	XX	XX
1RS	XX	XX	XX
1RL	XX	XX	XX
1TS	XX	XX	XX
1TL	XX	XX	XX
2RS	XX	XX	XX
2RL	XX	XX	XX
2TS	XX	XX	XX
2TL	XX	XX	XX
TOTAL PLAY		0000	
AVERAGE	XXMins		XXSecs
ADS CLEAR		NO	
NEXT PAGE			
EXIT			

◀▶ : CHOOSE ○ : ENTER

3. This page displays total time that the machine has been switched on, total playing times of single and linked games for downhill and slalem courses, total number of games played and average game time.

4. If ADS 'YES' is selected, all ADS Data will be reset.

5. If 'Next Page' is selected, the following screen will be displayed.

ADS 2/2

BASICS1	S2	S3	S4	S5	S6	S7	GOAL
1RS	XX	XX	XX	XX	XX	XX	XX
1RL	XX	XX	XX	XX	XX	XX	XX
1TS	XX	XX	XX	XX	XX	XX	XX
1TL	XX	XX	XX	XX	XX	XX	XX
2RS	XX	XX	XX	XX	XX	XX	XX
2RL	XX	XX	XX	XX	XX	XX	XX
2TS	XX	XX	XX	XX	XX	XX	XX
2TL	XX	XX	XX	XX	XX	XX	XX
MOGUL							
1RS	XX	XX	XX	XX	XX	XX	XX
1RL	XX	XX	XX	XX	XX	XX	XX
1TS	XX	XX	XX	XX	XX	XX	XX
1TL	XX	XX	XX	XX	XX	XX	XX
2RS	XX	XX	XX	XX	XX	XX	XX
2RL	XX	XX	XX	XX	XX	XX	XX
2TS	XX	XX	XX	XX	XX	XX	XX
2TL	XX	XX	XX	XX	XX	XX	XX
RACER							
1RS	XX	XX	XX	XX	XX	XX	XX
1RL	XX	XX	XX	XX	XX	XX	XX
1TS	XX	XX	XX	XX	XX	XX	XX
1TL	XX	XX	XX	XX	XX	XX	XX
2RS	XX	XX	XX	XX	XX	XX	XX
2RL	XX	XX	XX	XX	XX	XX	XX
2TS	XX	XX	XX	XX	XX	XX	XX
2TL	XX	XX	XX	XX	XX	XX	XX

6. This screen displays the the position on the course that the player reached at game over for single and linked game, downhill and slalem and each racer.
7. Pressing the View Change button will return the screen to the ADS 1 page.

6-3-7 Others

1. Select "Others" on the menu screen and press the View Change button.

This screen is used to test the PCB and to reset the game to factory settings.

6-4 Linking Two Machines

1. Ensure that the power is "OFF"
2. Loosen the two pozi head screws retaining the link cover bracket, located next to the mains-in socket on the rear of the monitor cabinet, and remove the link cover bracket.

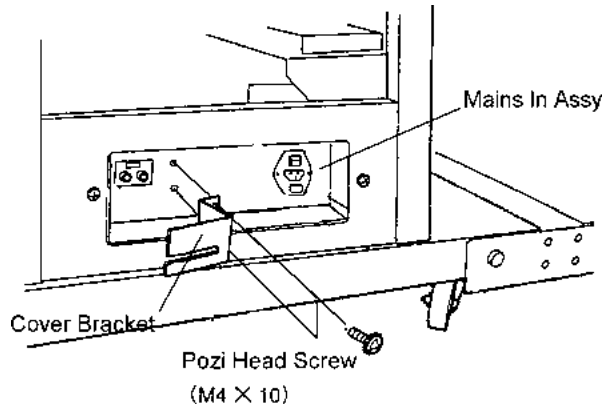

3. Set the slide switch on the link board to 'EXT' on both machines.
4. Use the supplied link cables to connect each link board. (See Diag.)

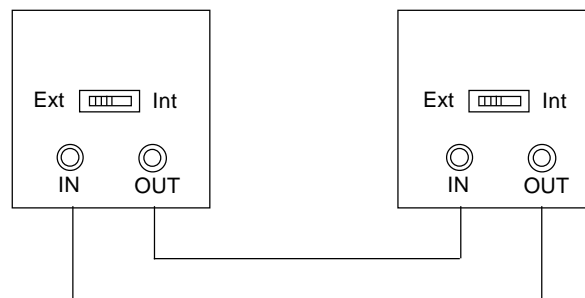

5. Turn the power to each machine "ON", and set the PCB ID using the test mode. (Refer to section [6-3-2 "Setting the Game Options" - page 13](#))

Note:- Set the left machine ID to 0 / LEFT and the right hand machine ID to 1 / Right. Settings other than this will cause the machine to operate incorrectly

6. Refit the link cover bracket and tighten the pozi head screws.

If the machines are used as single, non linked games ensure that the link cables are removed and the slide switch is returned to the "INT" position.

6-5 Initialization After Replacing Parts

Initialization must be performed after replacing the game PC board, Rom or Step Controls. If initialization is not performed, the game will not function correctly. During initialization, ensure that the step edges are level.

1. Select Step Adjust from the 'I/O Test' menu. The following screen will appear on the monitor.
2. Ensure that the skis are in the centre and level, then press the service button. 'INITIALIZE COMPLETE' will appear on the monitor display.
3. Select EXIT to return to the Main Menu Screen.

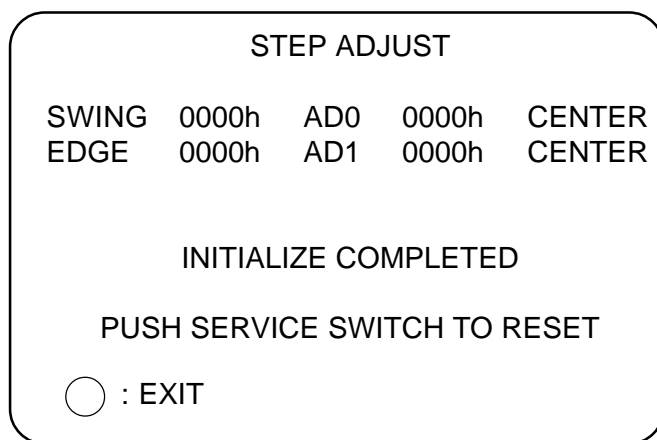

7. MAINTENANCE

GB

In order to prevent injury or electric shock to service personnel, ensure that the MAIN POWER IS OFF before attempting any maintenance.



Before performing any work not described in this manual, be sure to contact your distributor to receive instructions or answers to questions.

D

Vor Beginn aller Wartungsarbeiten (Fehlersuche, Reparaturen etc.) muß der Netzstecker gezogen werden.



Bei Arbeiten, die nicht in diesem Handbuch beschrieben werden, muß vorher der Händler zu Rate gezogen werden, da sonst keinerlei Haftung bei Beschädigungen und Verletzungen übernommen wird.

F

S'assurer que l'interrupteur soit sor OFF avant de commencer tout travail de maintenance (localisation d'une panne, réparations, etc.)



Si dans ce manuel il manque une information pour réaliser un quelconque travail, contacter votre distributeur, car aucune responsabilité ne sera acceptée en cas de damage ou de blessure.

S F

Varmista, että laite on kytketty POIS PÄÄLTÄ ennen työn aloittamista.



Ota yhteyttä maahantuojaan ohjeita varten, jos joudut tekemään työtehtäviä, joita ei ole esitelty huoltokirjassa, muuten vastuuta vioista tai loukkaantumisista ei ole.

7-1 Replacing the Push Button Switch or Lamp

1. Remove the ten security head screws (M5x12) and remove both side vac-forms.

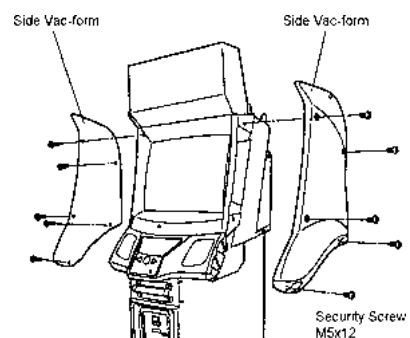

2. Remove the four security head screws (M5x12) and remove the play panel only sufficient to disconnect the connector, taking care not to strain any wires.

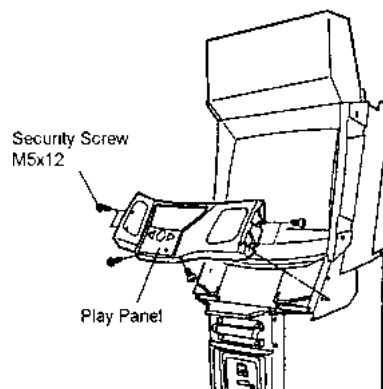

3. Remove the lamp/switch assembly by pulling it away from the switch body. Replace the lamp or switch.

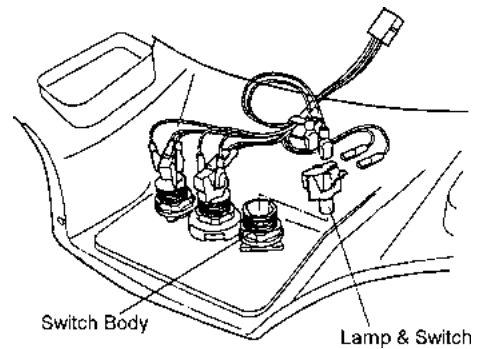

7-2 Replacing the Fluorescent Tube

- 1) Remove the two security head screws (M5x12) and remove the acrylic retaining bracket.
- 2) Remove the header acrylic
- 3) Replace the fluorescent tube.
- 4) Reassemble in reverse order.



Warning The fluorescent tube may be hot take care when handling the tube.

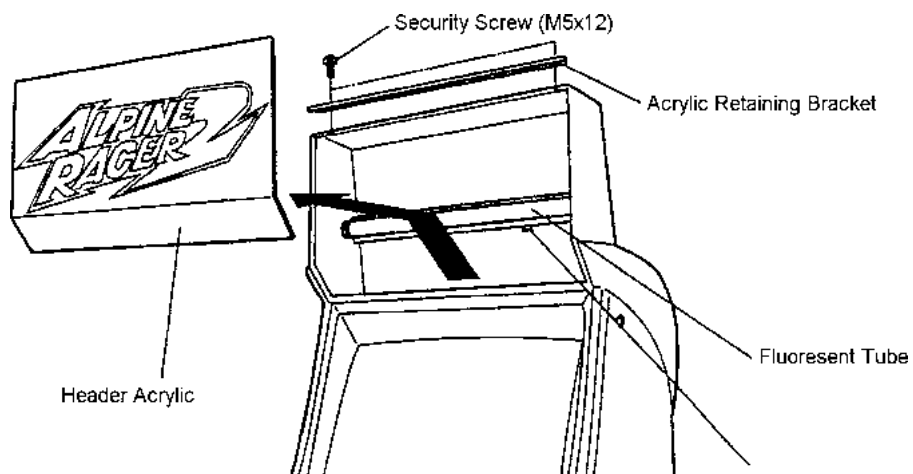

7-3 Replacing the Edge Potentiometer

1. Remove the four security head screws (M5x12) and remove the step front vac-form.
2. Remove the two hex head screws (M6x16) and remove the cover plate.

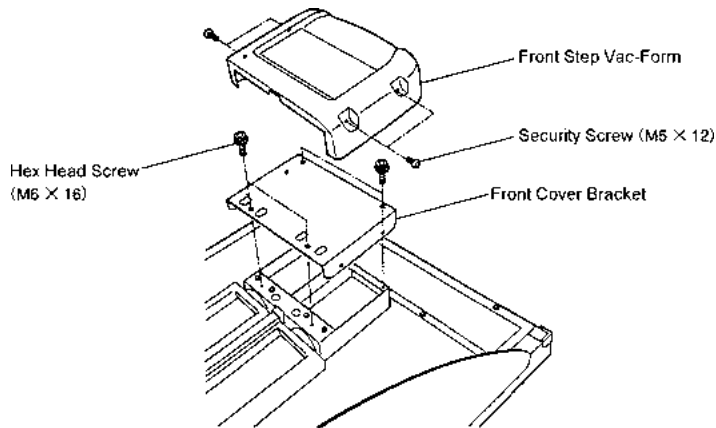

3. Disconnect the potentiometer connector.
4. Loosen the hex socket head set screw and remove the potentiometer complete with bracket.

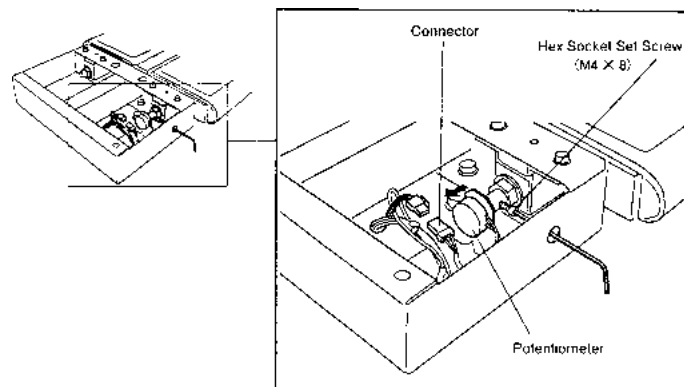

5. Replace the potentiometer taking care that the wires are re-soldered to the correct terminals.

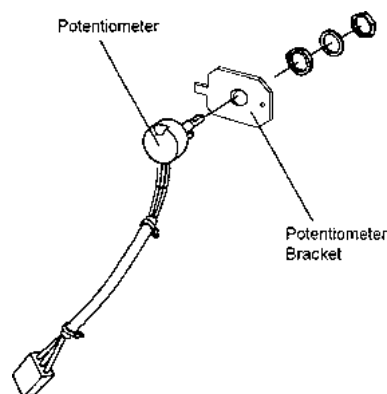

Note: Ensure that the lug on the potentiometer is engaged in the hole in the bracket when refitting the potentiometer.

7-4 Replacing the Swing Potentiometer

1. Remove the four security head screws (M5x12). Loosen the two security head screws (M5x12) and remove the base front cover.

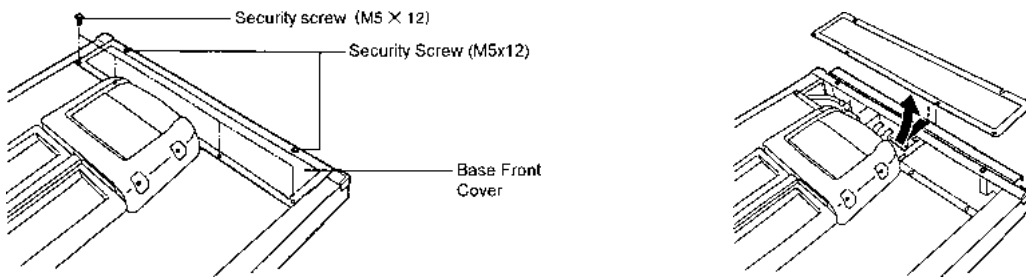

2. Disconnect the potentiometer connector.
3. Loosen the hex socket head set screw (M4x8) and remove the potentiometer complete with bracket.

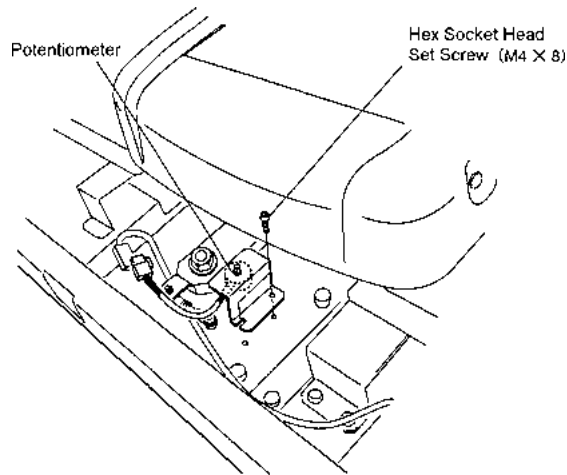

4. Replace the potentiometer taking care that the wires are re-soldered to the correct terminals.

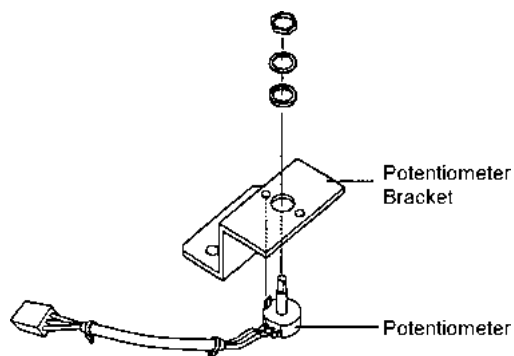

Note: Ensure that the lug on the potentiometer is engaged in the hole in the bracket when refitting the potentiometer.

8. PARTS

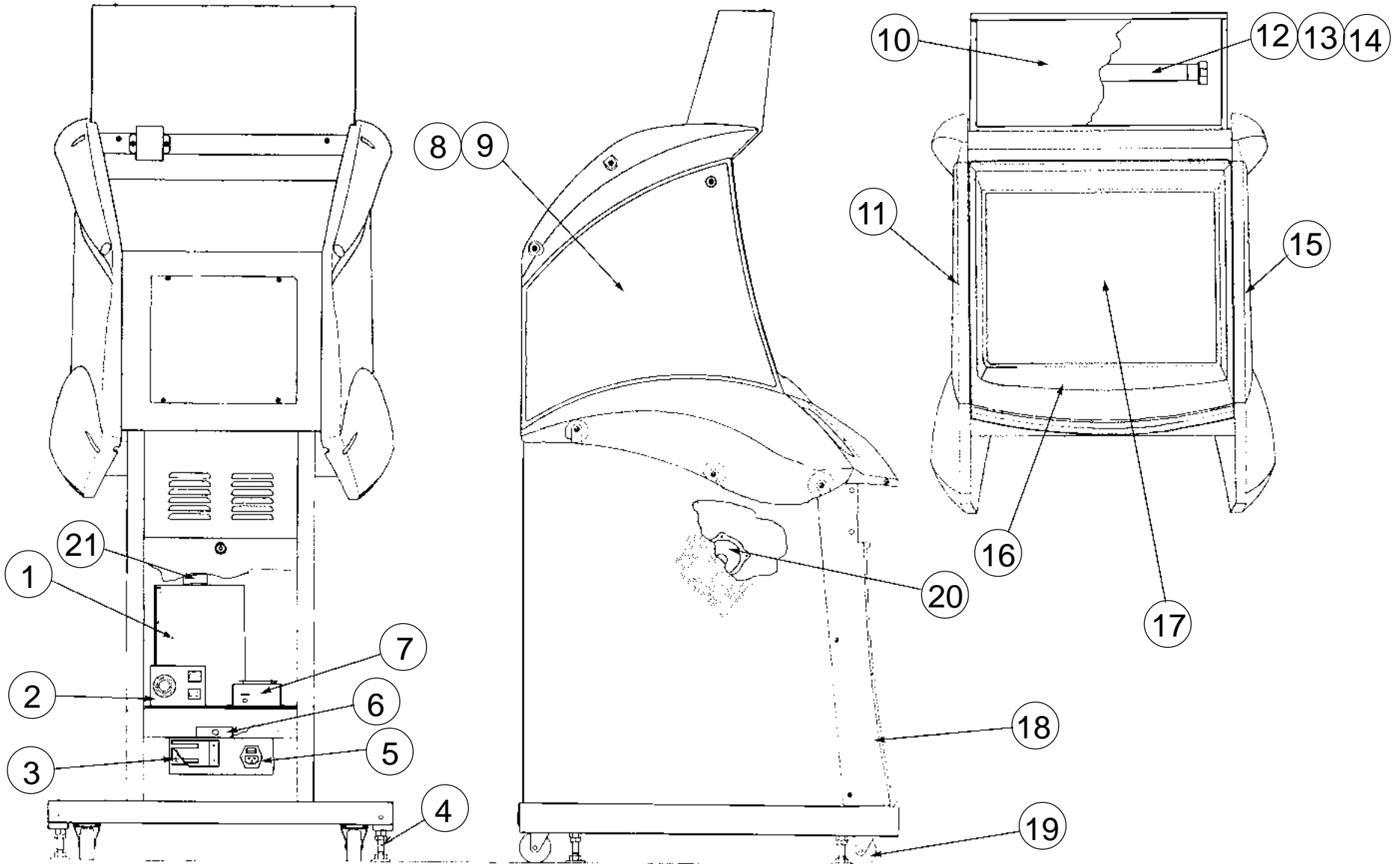

Item	Description	Part No
1	PCB Assembly- Alpine Racer 2	XAR-AR2PCB
2	Astec SA301-3400 SMPSU 5V 30A	83000008
3	Link PCB One Player	XAR2-LINKP-CB
4	M16x95 Adjustable Foot	88300079
5	Schaffner Mains-In Filter Assy	62500010
	Schaffner Boot	66000017
6	Interlock Switch	60000006
	Interlock Switch Cover	39000028
7	3 Channel Amplifier Ver3	46000036
8	Side Vac-form Decal - LHS	46000184
9	Side Vac-Form Decal - RHS	46000185
10	Header Acrylic	30000043
11	Monitor Housing Side Vac-Form - LHS	46000184
12	Fluorescent Tube 18" 15watt	64500009
13	Starter 240v 4-80w Universal	63000000
14	Choke	63300000
15	Monitor Housing Side Vac-Form - RHS	46000185
16	Monitor Vac-Form	46000186
17	Hantarex 28" Polo Monitor	84000026
18	Coin Door Vac-Form	46000191
19	Swivel Castor - 75mm	59000005
20	Loudspeaker 6%" Bass	62000068
21	Fan 230V 4%"	67000015

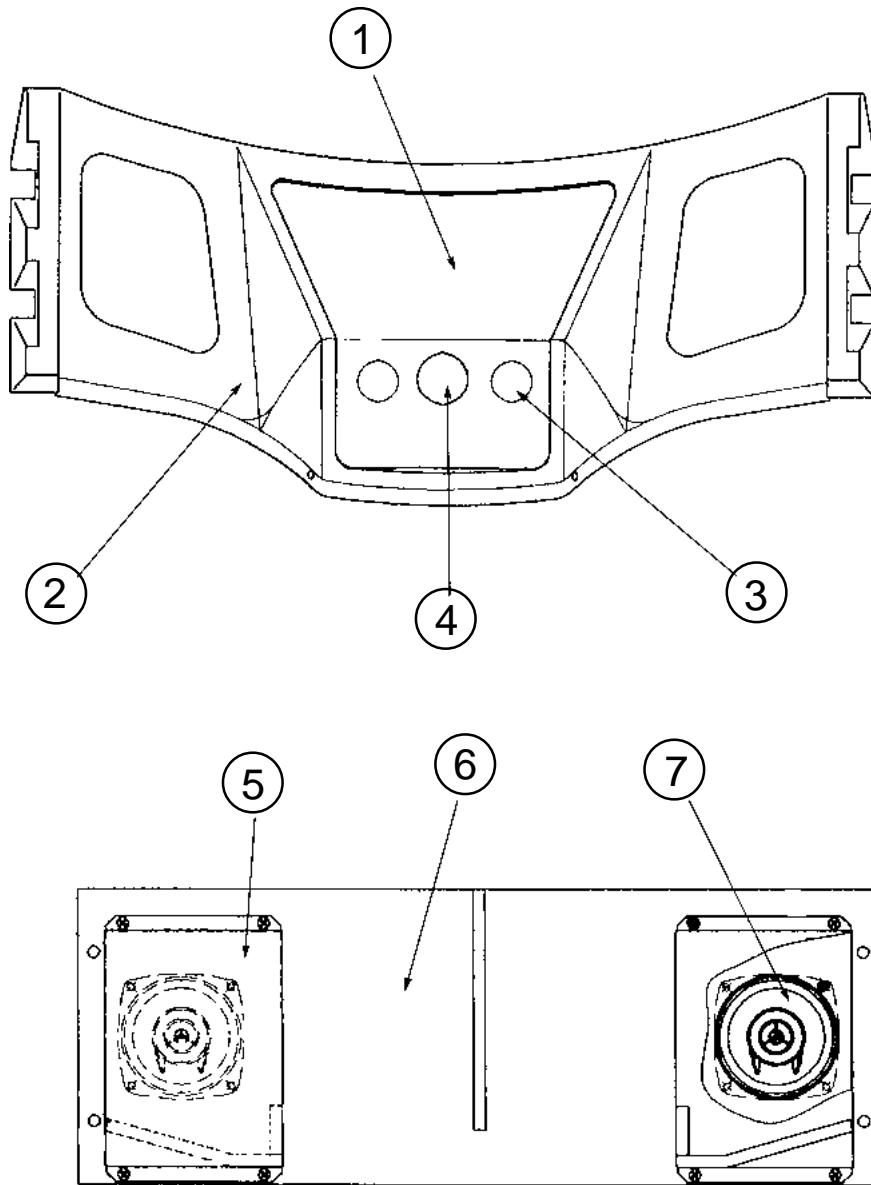

Item	Description	Part No
1	Play Panel Decal Ver2	40000437
2	Play Panel Vac-Form	46000196
3	Pushbutton Assy - MCPB Red	60200247
4	Pushbutton Assy - MCPB Yellow	60200251
5	Play Panel Loudspeaker Mesh	46000195
6	Play Panel / Speaker Mounting Wood	37100113
7	Loudspeaker 5% ⁰⁰ " Mid High	62000065

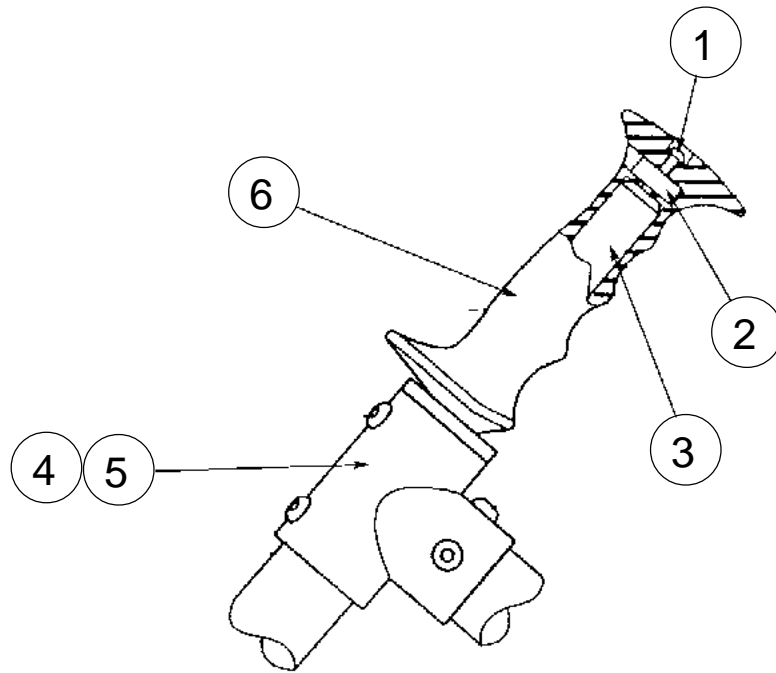

Item	Description	Part No
1	M4x20 Pz Pan Head - Black	26300391
	M4 Flat Washer - Black	28000132
2	Ski Pole Grip Washer	45000606
3	Ski Pole Grip Bar	46000239
4	Ski Pole Joint Casting - LHS	46000209
5	Ski Pole Joint Casting - RHS	46000210
6	Ski Pole Grip - Black Slim Line	46000245

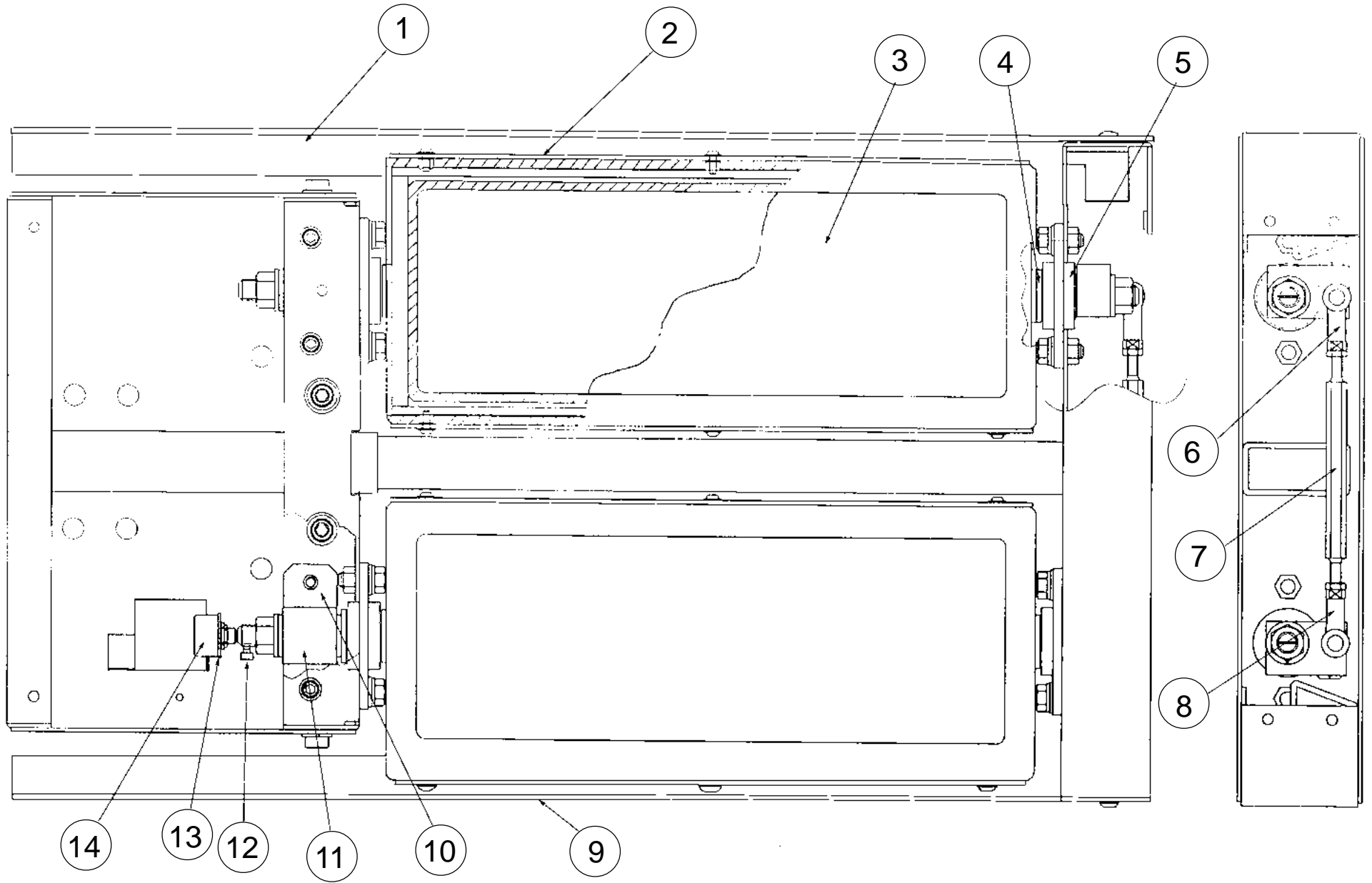

Item	Description	Part No
1	Foot Protection Bracket - LHS	46000237
2	Step Rubber Fixing Plate	46000222
3	Step Rubber	46000223
4	Step Tray Shaft Spacer Washer	46000220
5	Bearing - 80FL-20	46000181
6	Link Ball - BL 6D	46000228
7	Step Rear Swing Rod	46000217
8	Link Ball - BL 6DL	46000229
9	Foot Protection Bracket - RHS	46000238
10	Rosta Spring Retaining Bracket	46000218
11	Rosta Spring DR-S-18x30	45000573
12	M4x8 Hex Socket Set Screw	26300083
13	Potentiometer Mounting Bracket	46000219
14	Edge Potentiometer	X008-023

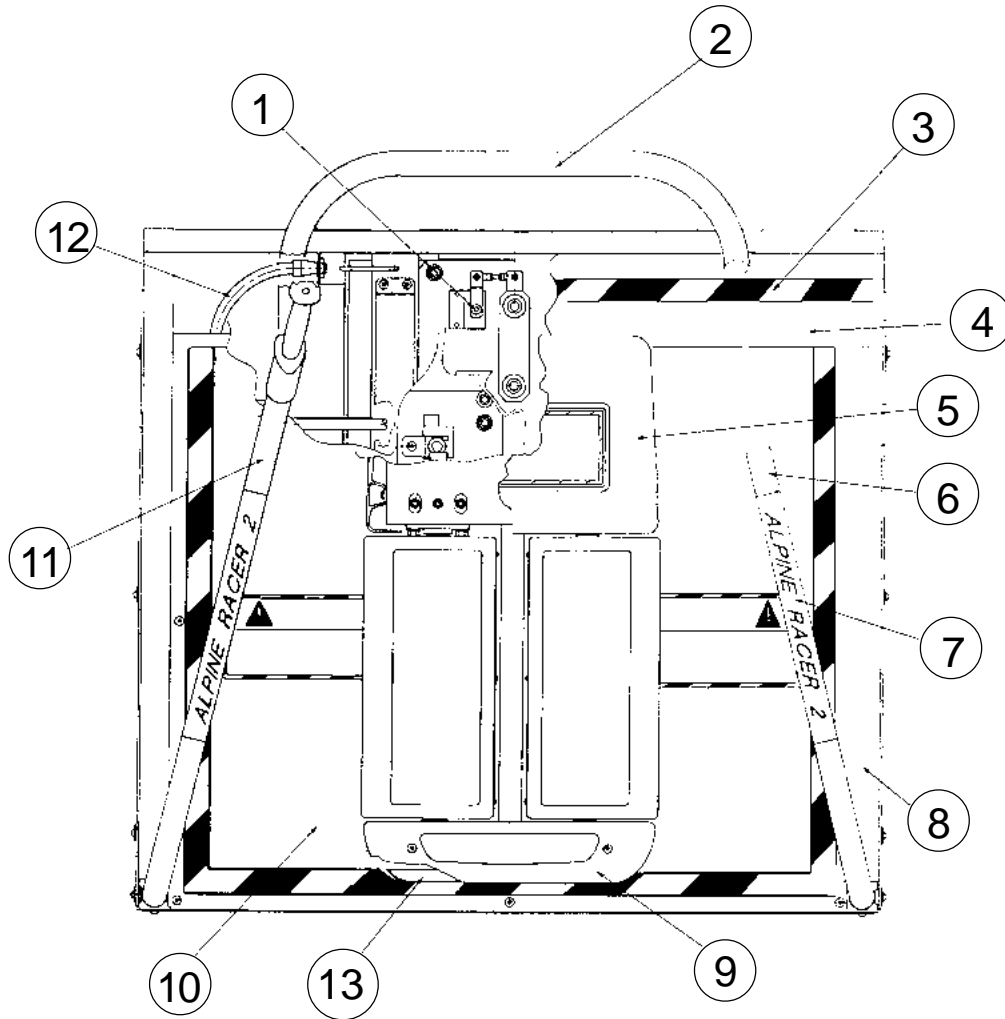

Item	Description	Part No
1	Swing Potentiometer	X008-023
2	Ski Pole Joint Bar	46000206
3	Step Section Base Top Decal - Front	40000415
4	Step Section Base Top Cover - Front	46000202
5	Step Vac-Form - Front	46000226
6	Ski Pole - RHS	46000205
7	Ski Pole Decal	40000405
8	Step Section Base Top Cover - Rear	46000201
9	Step Rear Top Vac-Form	46000227
10	Step Section Base Top Decal - Rear	40000416
11	Ski Pole - LHS	46000204
12	Conduit Pipe - PAFS13	46000232
13	Step Rear Vac-Form	46000225

9. SCHEMATIC

