

namco®



Operators Manual

IT IS THE RESPONSIBILITY OF THE OPERATOR TO MAINTAIN CUSTOMER SAFETY
AT ALL TIMES, AND IT IS IMPERATIVE THAT THE DETAILS SET OUT IN THIS
MANUAL ARE FOLLOWED PRECISELY.

© 1996 **NAMCO LIMITED** all rights reserved.

No part of this publication may be reproduced by any mechanical, photographic or electronic process, or in the form of phonographic recording, nor may it be stored in a retrieval system, transmitted or otherwise copied for public or private use, without permission from
NAMCO EUROPE LIMITED.

While the information contained in this manual is given in good faith and was accurate at the time of printing, **NAMCO EUROPE LIMITED** reserve the right to make changes and alterations without notice.

This machine has been manufactured in accordance with European Community Directives, and has been tested and complies with the EMC Directive 89/336/EEC by the application of EN55014 and EN55104 standards (see opposite), and as such bears the **CE** marking. Any changes or modifications to this machine must be in accordance with European Community Directives. Any unauthorised changes to this product, may contravene such Directives.

Under some conditions of extreme external interference, e.g. radio transmissions, electrostatic discharge or mains borne transients, some degradation of performance may occur. However the machine will recover normal performance once the source of interference has ceased or been removed.

Note:-

If the game processor resets due to an interruption or reduction of the mains voltage any credits established may be lost.

This game is not a machine as defined by the Machinery Directive 89/392/EEC

Published by:
NAMCO EUROPE LIMITED
Namco House,
Acton Park Estate,
The Vale,
London W3 7QE

Phone:- 0208-324-6000

Fax:- 0208-324-6010

SAFETY WARNING

In order to use this machine safely, be sure to read this Operators Manual carefully before installation, adjustment or use of this machine.

Whenever the owner of this machine entrusts dis-assembly, installation, adjustment or routine maintenance to another person, the owner should ensure that that person read the appropriate precautions and relevant sections of this manual before starting work.

In order that no accidents occur when the machine is in operation, strictly follow the notes on safety as described below.

This manual along with the Installation Manual (where applicable) form an integral part of the equipment and must be available to the operating and service personnel at all times.

This machine is for indoor use only and should be used only for the purpose intended.

Namco Ltd. bears no responsibility for accidents, injury or damage resulting from unauthorized changes to, or improper use of this machine.

SAFETY NOTES

The following safety notes are used throughout this manual. Familiarize yourself with each of these notes and its meaning before installing, servicing or making adjustment to this machine.

WARNING **Warning denotes a hazard that could result in injury or death. Do not proceed beyond a warning note until the indicated conditions are fully understood and met.**

CAUTION Caution denotes a hazard that could result in damage to the machine. Do not proceed beyond a warning note until the indicated conditions are fully understood and met.

General Safety Considerations

- WARNING**
- Only operate this machine after checking that has been installed correctly and in accordance with the manual.
 - Parts of this machine move during game play, so there are places where the distance between the stationary section and moveable section changes. There are warning notices to keep hands and feet clear of moving parts, however if the operator feels that a person is in any danger, he should warn that person accordingly.
 - The warning notices must always be kept in good condition and replaced if worn, so that the customer can read them clearly.
 - If there is an error or problem with the machine, operation must be stopped immediately and the problem rectified before any further use.
 - Installation, service, adjustment or routine maintenance should be carried out by suitably qualified persons only.
 - For continued protection against fire hazard, replace the mains-in fuses only with the same type and rating. The use of other fuses or material is prohibited.
 - The power supply inside the monitor will remain hot and have areas of high voltage even though the machine has been turned OFF, and there is the possibility of burns or electric shock. Be careful not to touch these areas.
 - To prevent possible electric shock due to failure, this machine **MUST** be fitted with a securely connected EARTHED plug.
 - If at any time the mains supply lead becomes damaged it must be replaced immediately.
 - Do not turn the power switch ON until the machine has been installed correctly.
-

- CAUTION**
- Before connecting the machine to the mains supply, ensure that the machine is set for the correct voltage and that the correct fuses are fitted.
-

1. SPECIFICATIONS

POWER SUPPLY:- 230volts AC

AMBIENT OPERATING TEMPERATURE:- +5°C to +35°C

MONITOR:- Pioneer 50" Projector Monitor (SD-V5070NE/MYVZ)

COIN ACCEPTOR:- Mars CashFlow - 1 Channel

DIMENSIONS:-

Assembled	1265(w) x 2850(d) x 2270(h)
Front Assembly	1150(w) x 720(d) x 2070(h)
Ride Assembly	1150(w) x 2130(d) x 1320(h)
Header Assembly	1150(w) x 560(d) x 200(h)
Coin Tower	219(w) x 245(d) x 715(h)

WEIGHT:-

Assembled	534kg
Front Assembly	235kg
Ride Assembly	250kg
Header Assembly	25kg
Coin Tower	24kg

ACCESSORIES:-

Keys:	(Cash Door)	2
	(Coin Door)	2
	(Back Door)	2
	IEC Mains Lead	1
	Operators Manual	1
	Monitor Manual	1
	CashFlow Documents	1
	Potentiometer	1
	Cashbox Base Plate	1
	Cash Tower Vac-Form Assy.....	1
	M10x25 Security Button Head S/Steel	9
	M10 Spring Washer S/Steel	9
	M10 Flat Washer S/Steel	9
	M8x60 Hex Head Set Screw S/Steel	4
	M8 Spring Washer S/Steel	4
	M8 Flat Washer S/Steel	4
	M6X30 Hex Head Set Screw - BZP	3
	M6 Spring Washer - BZP	3
	M6 Flat Washer - BZP	3
	M4X12 Pz Pan Head - BZP	4
	M4 Spring Washer - BZP	4
	M4 Flat Washer - BZP	4
	M10 Security Wrench	1
	M5 Security Wrench.....	1

2. HOW TO PLAY

This is a racing game for one player. The player can select from two courses, of different difficulty level, and to race for position against the computer.

- The objective of the game is to cover the selected course as fast as possible within the specified time.
- If the finish line is reached within the specified time, the player's position, time and jump distance (*) is displayed and the game is over.

** There are three continuous jumping platforms during the course where the player competes for jumping distance. The distances jumped are displayed at game over if the player has reached the finish line within the game time.*

- The game is over if the specified time period reaches 000

(1) Operation

- Steering control is performed by tilting the ride assy to the left or right. Tilt the ride assy to the left to turn left and tilt it right to turn right.
- The speed is controlled by operating the accelerator lever on the handle of the control arm assembly. Pull the lever to increase speed and release the lever to slow down.
If the control arm is raised, the viewpoint moves up, and the viewpoint moves down when the arm is lowered.
- By moving the control arm up and down rhythmically, it is possible to perform mini jumps at places other than the jump ramps. (expert course only)
- If the handle arm is held when splashing down onto the water from a jump, it is possible to go under the water for a short time. (expert course only)

(2) Starting the Game

- After inserting the correct amount of money and pressing the start button, the Select Course screen will be displayed. Tilt the ride assy left or right to choose the required course and then operate the accelerator lever to select the course chosen.
- The game starts when the "GO" sign is displayed on the screen.
- The game is over if the game time reaches 000
- If the finish line is reached within the game time, the race results are displayed and the game is over.
- A player can enter their name if they reach the finish line in a fast time.

3. MAJOR COMPONENTS

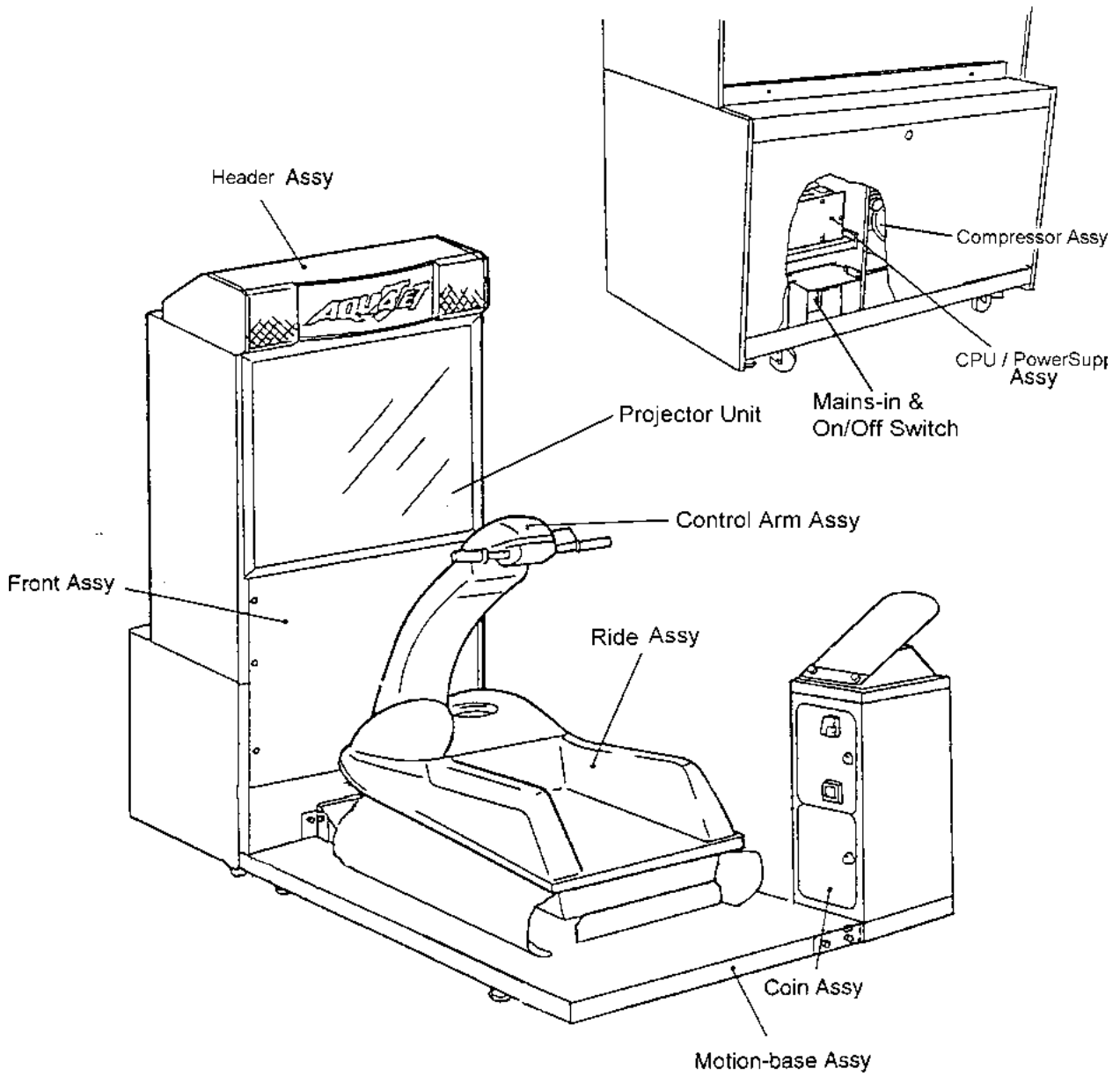

4. Moving the Machine

- WARNING**
- **When moving or carrying the game, make sure to dis-assemble the game into four parts: header assembly, Front assembly, ride assembly and coin tower.**
 - **The game is fitted with castors to make it easier to move. Take care when moving the machine on an inclined surface.**
 - **The game is still heavy even when separated in to four parts, ensure that there is an adequate number of people to move the game.**
 - **The Header Assembly has a forward centre of gravity, so it is important that at least two people are used to fit or remove the Header Assembly.**
 - **The fitting position of the Header Assembly is very high, and it is important that a means of reaching the height safely, without stretching, is available. (e.g. steps, step stools etc.)**
 - **The overall height of the main assembly is 2300mm, take care of any overhead obstructions e.g. light fixtures.**

NOTE: The Front assembly can be further dismantled by removing the projector from the projector base. (See [section 5-1](#) “Removing the Projector from the Projector Base”.)

5. INSTALLATION

Notes on Installation

WARNING NEVER turn the power to the machine ON until installation has been completed.

WARNING in order to prevent possible electric shocks, be sure that the machine is connected to the mains supply with a securely connected earthed plug.

WARNING So that customers are not injured by the movement of the Aqua-Jet, ensure that there is at least 500mm separation between other machines or walls.

CAUTION In order to avoid damage to the machine due to mis-operation, ensure that the voltage of the mains supply is 230volts AC.

NOTE If the location site of this machine has a polished floor it is recommended that rubber pads are fitted under the level adjusters to prevent the machine sliding on the floor.

NOTE In order to gain access to the Power Supply and CPU assemblies, make sure that the rear of the main cabinet is separated from a wall or other machine by at least 500mm.

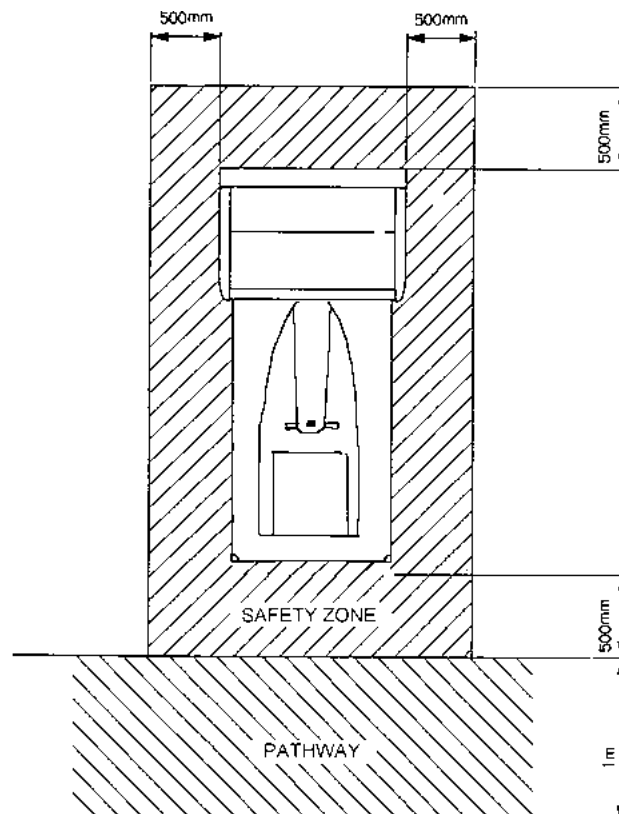

WARNING

This machine is designed for **indoor use only**.

Do not install the machine in the following places.

① Outdoors

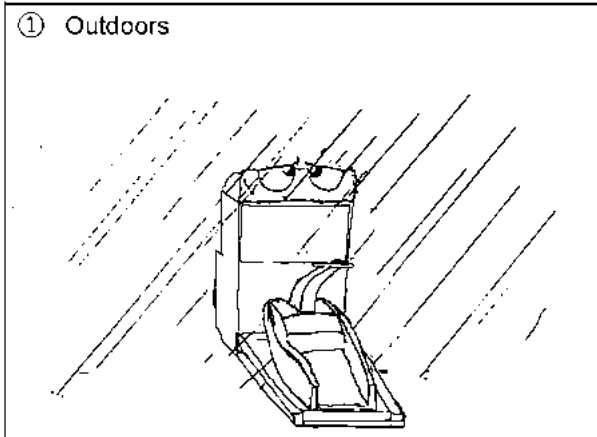

② Direct sunlight, places with excessive humidity or dust, places where there is water leakage, near air-conditioning or heating equipment, places with excessively high or cold temperature.

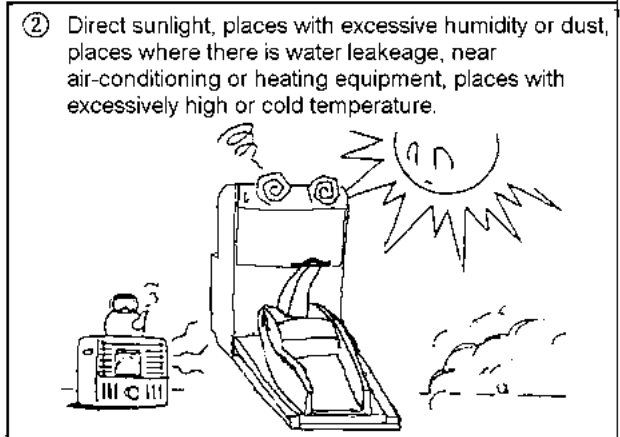

③ Places where it would be in the way of emergency exits or fire extinguishing equipment.

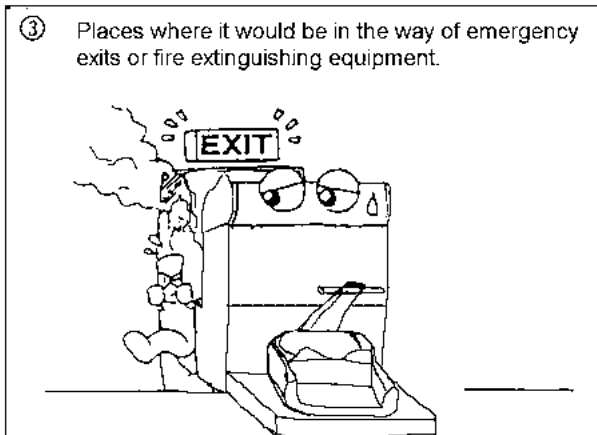

④ Unstable places or places with excessive vibration.

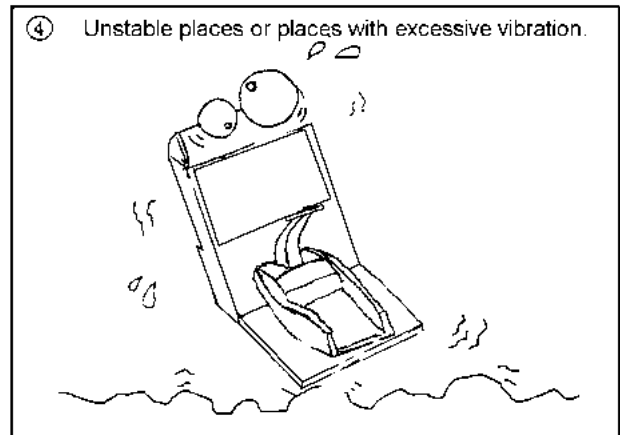

⑤ Places that are not level.

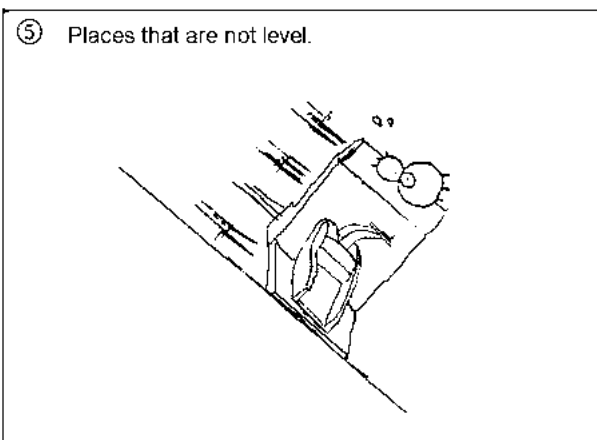

5-1 Removing the Projector from the Projector Base.

- WARNING** • Make sure that the power is turned OFF before commencing any work.
- WARNING** • The projector Assy weighs approx. 100kg. At least four people should be used to remove it from it's base.
- CAUTION** • The projector assy. is a precision assembly and should be handled with extreme care, avoiding heavy knocks.

1. Remove the six security screws (M5x30) and remove the front door.
2. Disconnect the two projector connectors.
3. Remove the four hexagonal bolts (M10x130)

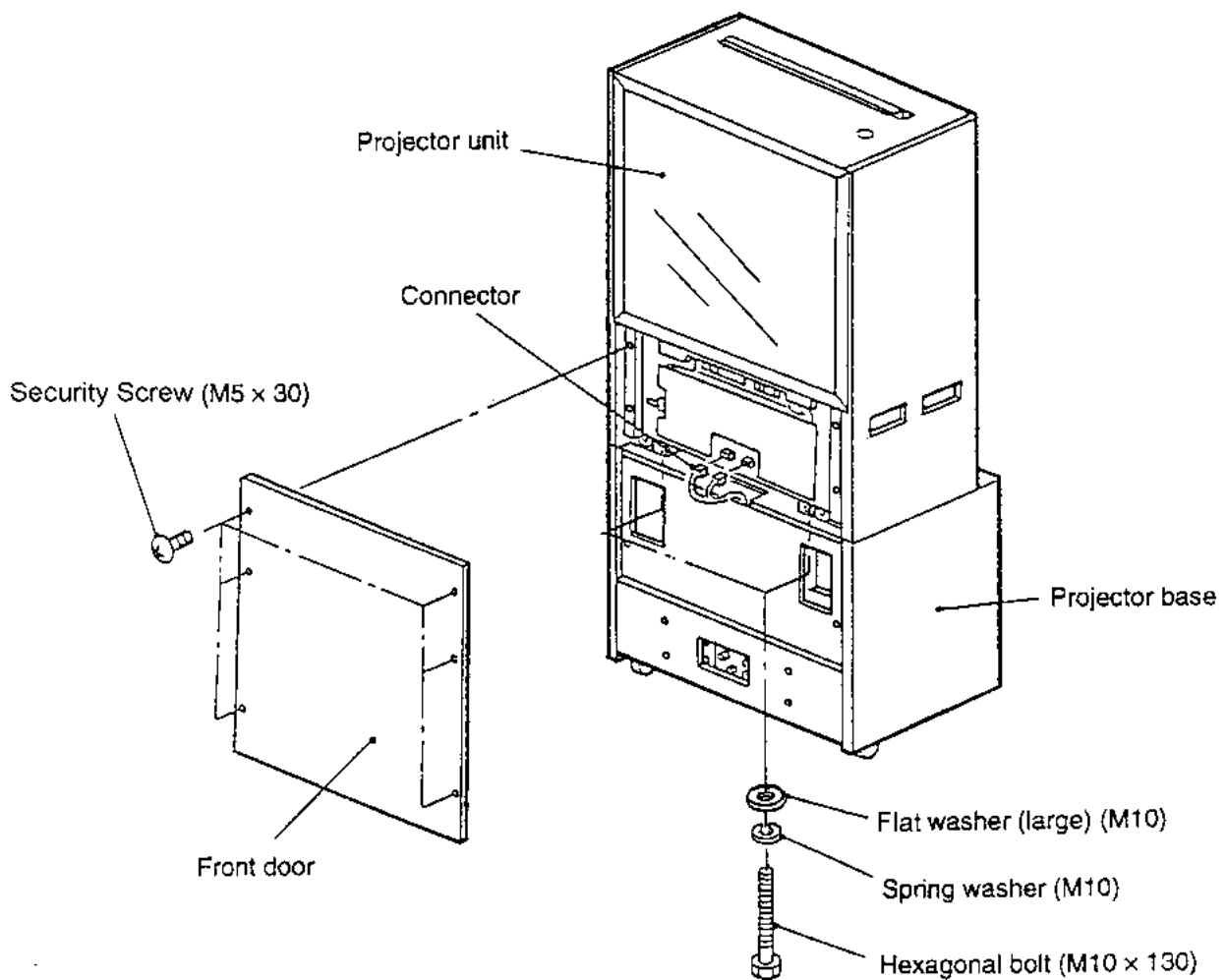

4. Remove the two security screws (M5x30) and remove the small cover.
5. Remove the two pozi head screws (M5x30), unlock and remove the back door only enough to be able to disconnect the fan connector.
6. Disconnect the fan connector and remove the back door fully.
7. Remove the four hexagonal bolts M10x130.

WARNING After the four hexagonal bolts have been removed, the projector is only resting on the base. Take care that the projector is not accidentally knocked or moved to prevent the projector falling and causing injury.

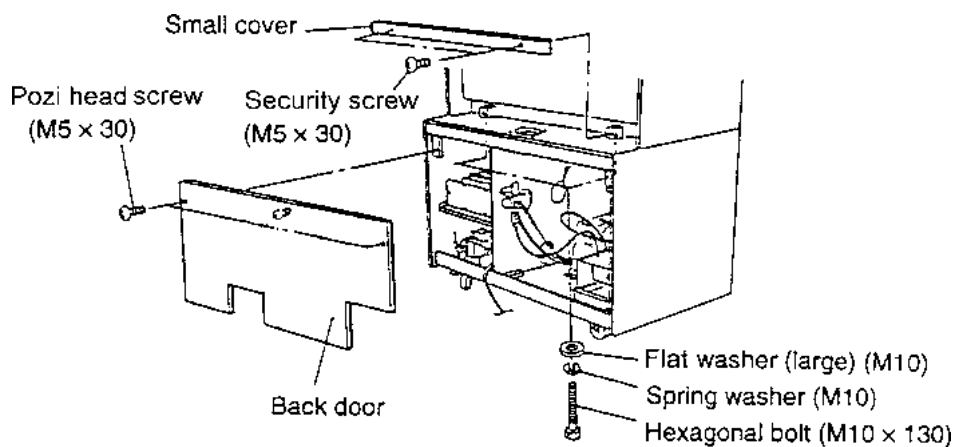

8. Lift the projector unit up by approx 10cm from the base then carry it backward or forward and gently lower it to the ground.

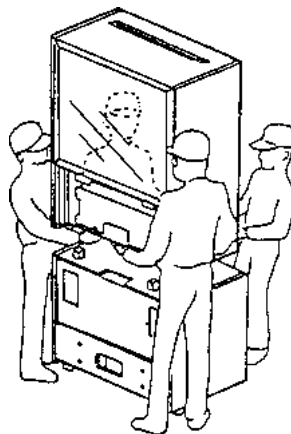

9. When replacing the projector unit on top of the base, ensure that the guides on the top of the base fit inside the projector unit base.

WARNING Take care not to trap fingers or clothing when replacing the projector unit back on to the base.

5-2 Fitting the Header Assembly

WARNING • The Header Assembly has a forward centre of gravity, so it is important that at least two people are used to fit or remove the Header Assembly.

WARNING • The fitting position of the Header Assembly is very high, and it is important that a means of reaching the height safely, without stretching, is available. (e.g. steps, step stools etc.)

1. Place the Header Assembly on top of the monitor.
2. Lift the right end of the Header Assembly (as viewed from the front), and connect the connector to the top of the monitor. (Ensure that a second person prevents the Header Assembly from falling.)
3. Slide the Header Assembly towards the back of the monitor until it is fully engaged in the locating bracket, taking care not to trap any wires.
4. Fasten the Header Assembly with the 3 off M6x30 Hex head screws, flat and spring washers.

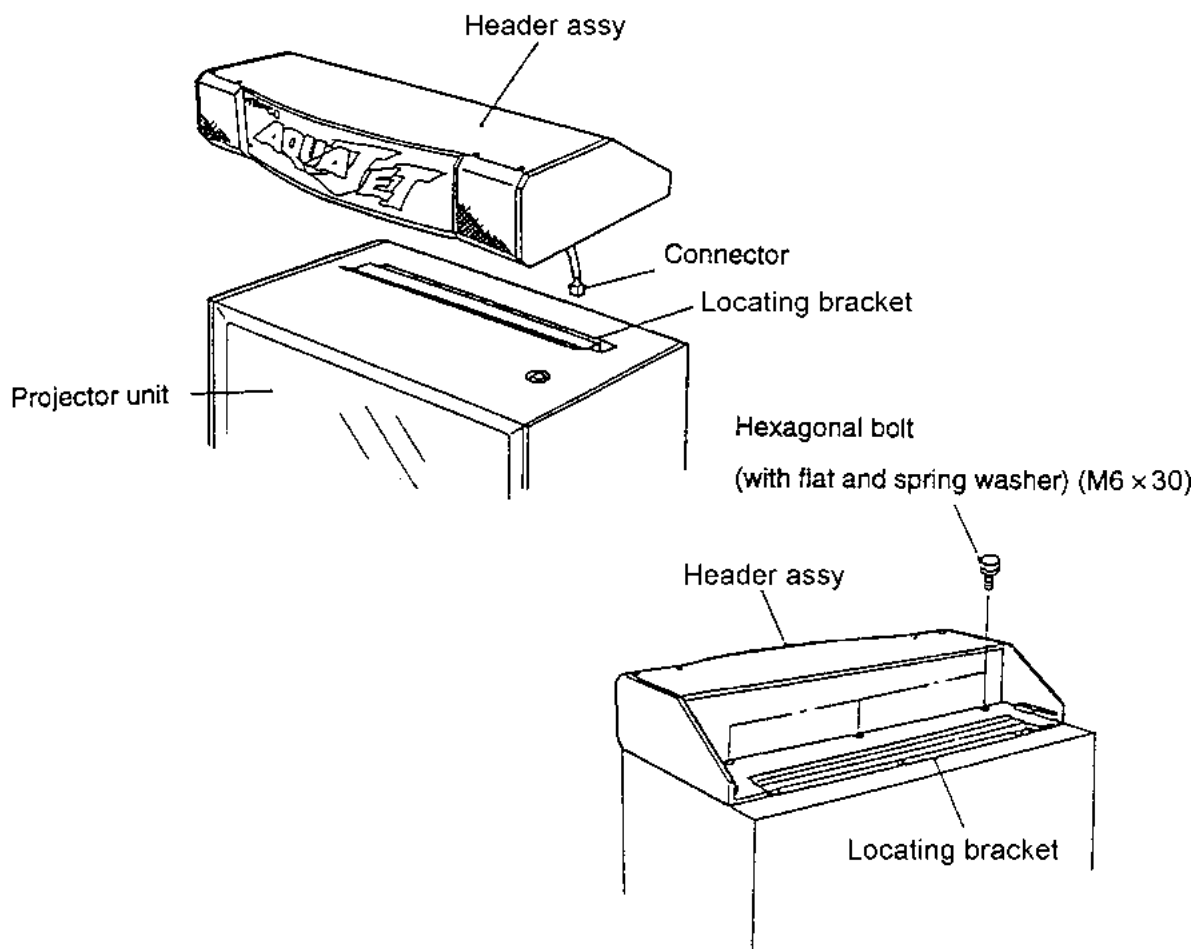

5-3 Connecting the Ride Assy to the Front Assy.

1. Push the Ride Assembly close to the Front Assy.
2. Connect the three connectors and the air tube.
3. Push the Ride Assy fully up to the Front assy, taking care not to trap any wires.
3. Fit the Joint Brackets, finger tight, to the Front Assy using 4 off Hex Head Set Screws (M8x60), Spring and Flat Washers for each bracket. When all screws have been located, tighten all the screws fully.

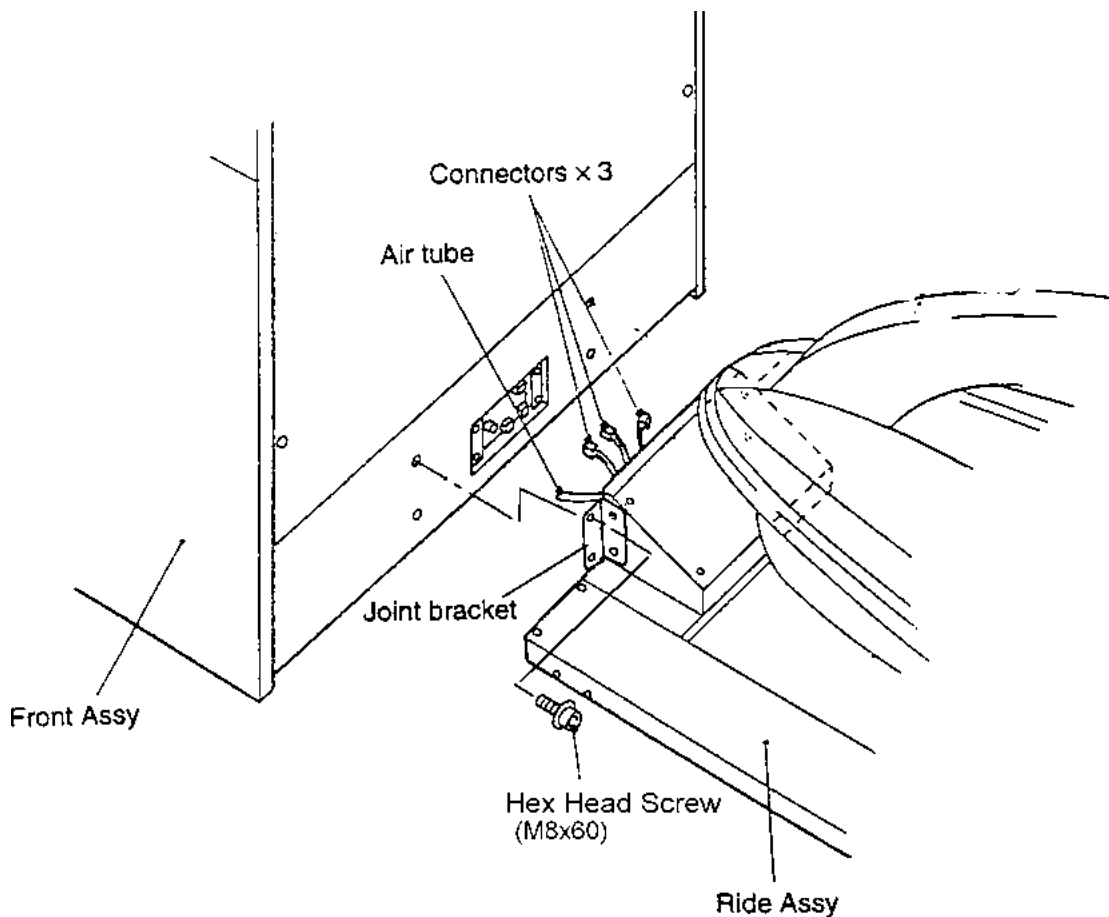

5-4 Assembling the Coin Tower

1. Connect the connector and place the coin tower on to the base assembly.
2. Attach the coin tower to the base, taking care not to trap any wires, using the nine security button head screws (M10x25), flat and spring washers.
NOTE:- Ensure that the two security screws are fitted to the inside of the cash box area.

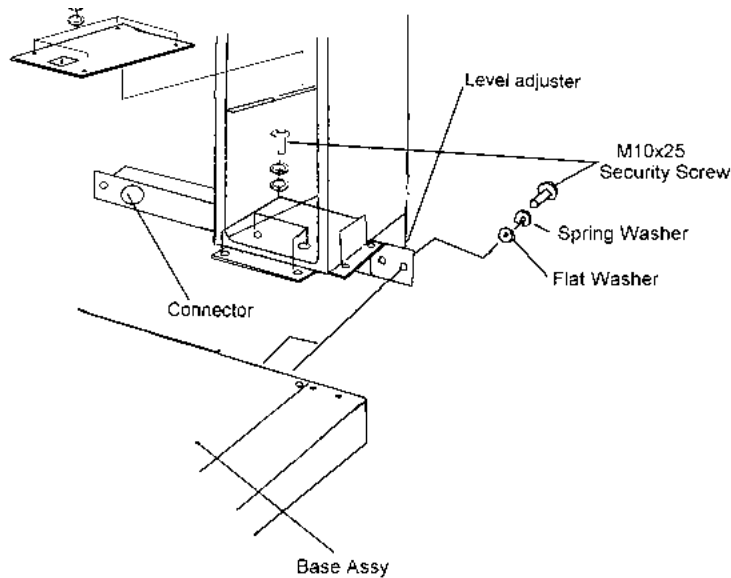

3. Fit the cashbox plate to the inside of the coin tower using four pozi head screws (M4x12), spring and flat washers.
4. Place the instruction panel into the panel support bracket and fasten to the coin cap using the two security screws (M5x20).

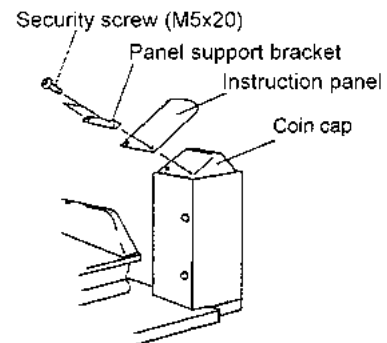

NOTE:-

When the machine is fully assembled and in its final position, lower the 12 level adjusters, (4 on the Monitor Cabinet, 6 on the Ride Assy and 2 on the coin tower), with a spanner so that the machine is level and all castors are raised from the floor by approx. 5mm. Tighten the lock nuts with a spanner to ensure that the level adjusters do not move.

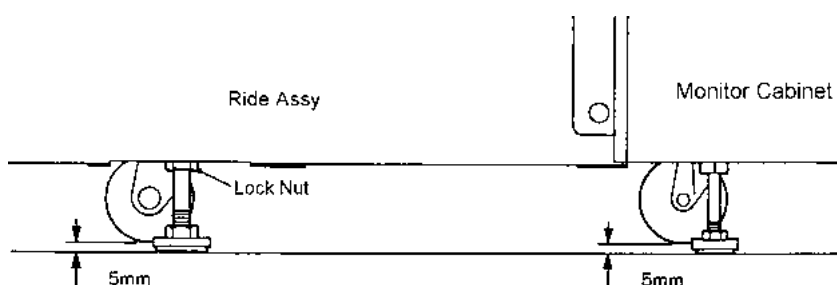

5-5 Adjusting the Projector

Due to vibration during moving and assembly of the machine, the projector convergence may require adjustment. If this is necessary, adjust the projector using the following procedure.

For details on how to adjust the projector, refer to the "Projector Adjustment Manual".

NOTE:

- If the correct adjustment procedure is not followed, or the wrong buttons are pressed, it may be impossible to return the projector to its normal condition.
 - The details for adjusting the projector may differ depending upon which projector is used, be sure to follow the adjustment procedure according to the "Projector Adjustment Manual" that is supplied with the game.
1. Remove the six security screws (M5x30) and remove the front door.
 2. Adjust the projector according to the "Projector Adjustment Manual".
 3. When adjustment is complete, refit the front door.

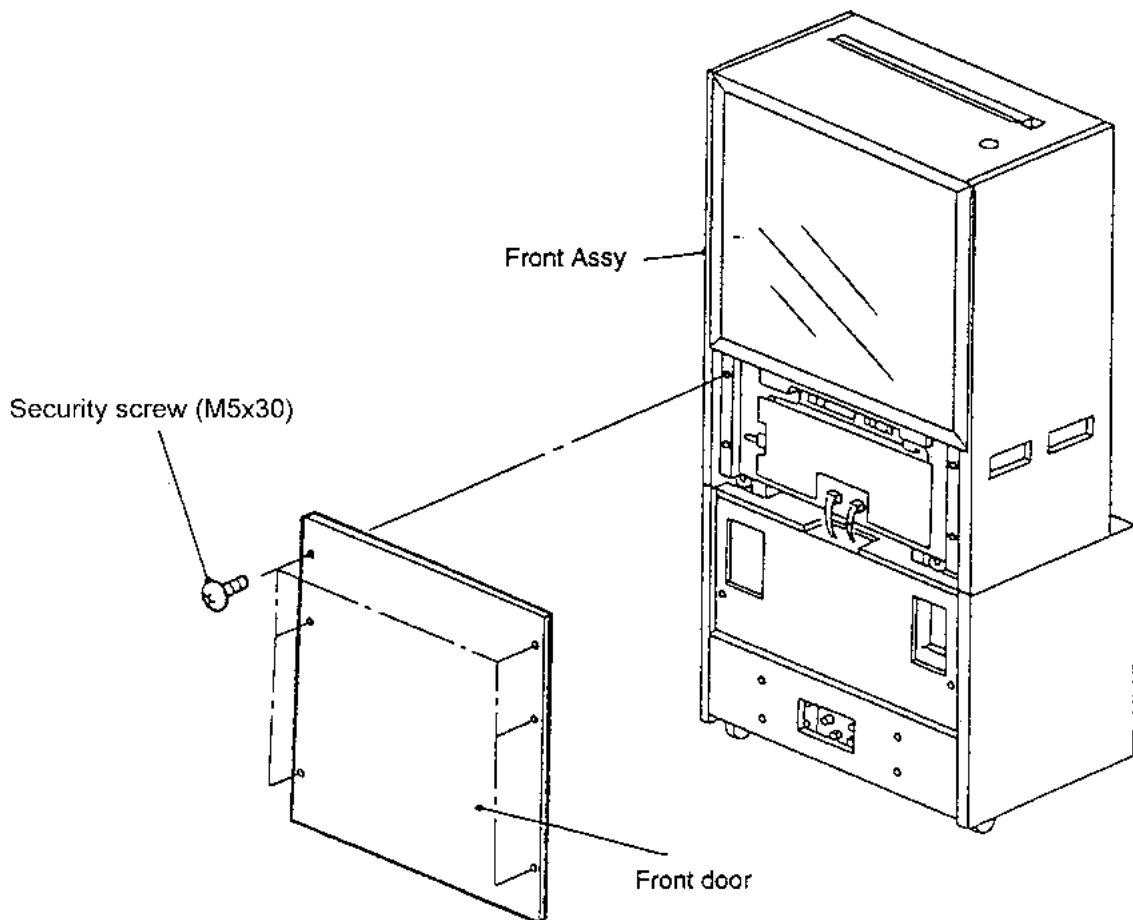

6. ADJUSTMENTS

WARNING Adjustments or maintenance on this machine should be done by qualified personnel only.

6-1 Turning on the Power

After the machine has been installed, turn ON the power. The Power switch is located on the rear of the Main cabinet. (See section 3 “Major Components” (page 3).)

6-2 Adjustment Switches

The adjustment switches are located inside the coin door.

1. Service Switch
Press this switch to obtain game credits without incrementing the play meters.
2. Test Switch
Slide this switch “ON” to enter test mode.
Test mode allows game testing and the changing of game settings. (Refer to section 6-3 “Test Mode” (page 14).)

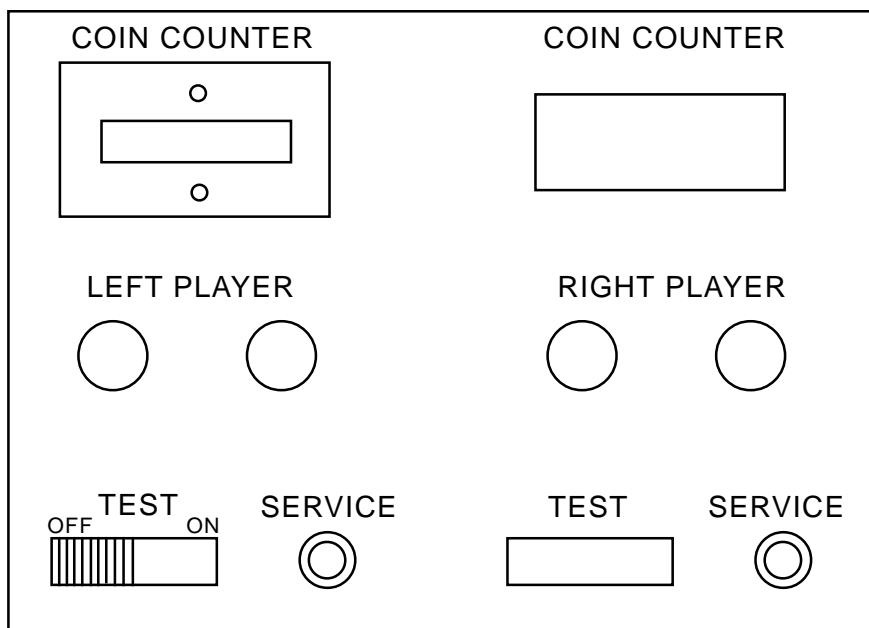

6-3 Test Mode

1. Open the coin door and slide the test switch "ON". The "Menu Screen" will be displayed on the monitor.
2. Select the test required by moving the control handle up or down. The colour of the selected test will change to red and blink.
3. Enter the selected test by pressing the start button. Select "EXIT" to return to the "Menu Screen"
4. After testing is completed, ensure that the test switch is returned to the "OFF" position to return to game mode.

The Test Switch must always be in the "OFF" position for normal game mode.

MENU	
COIN OPTIONS	(1) Sets the price of play. (See 6-3-1)
GAME OPTIONS	(2) Sets the game options. (See 6-3-2)
I/O TEST	(3) Used for testing the switches, control potentiometers and air spring. (See 6-3-3)
MONITOR TEST	(4) Used for adjusting the monitor. (See 6-3-4)
SOUND TEST	(5) Used for adjusting the speaker volume. (See 6-3-5)
ADS DATA	(6) Displays the accumulated game data.
OTHERS	(7) Used for testing the PC boards and for initializing all of the settings.

CONTROL ARM:CHOOSE START:ENTER

(NOTE):-

- If the control arm has not been initialized correctly, it may not be possible to select items correctly. If this happens, refer to section 7, "Initialization", and initialize the position of the control arm.

6-3-1 Coin Options

- a. Select item (1) "COIN OPTIONS" on the menu screen, to set the game cost and related settings.
- b. Move the Control Arm up or down to select the required item then press the start button.
- c. Press the start button to change the settings.
- d. Select "EXIT" and press the start button to return to the menu screen.

Note:- The price of play on this machine is set within the Cashflow Coin Mech. Ensure that the Coin Options on the screen are set as shown in the following table.

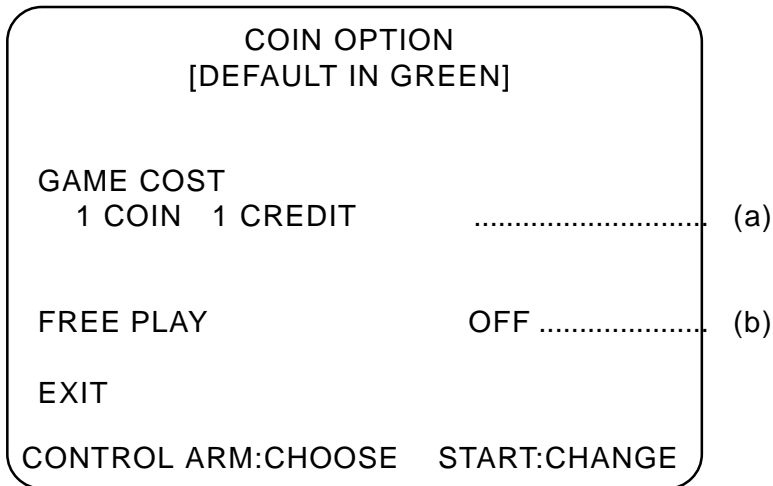

ITEM	CONTENTS	FACTORY SET
(a) Game Cost	Coins required for one credit - - - - - settable 1 - 9	1
(b) Free Play	No coins required for game - - - - - On / Off	OFF

6-3-2 Game Options

- a. Select item (2) "GAME OPTIONS" on the menu screen to set the game options.
- b. Move the Control Arm up or down to select the required item.
- c. Press the Start button to change the settings. The settings will change each time the start button is pressed.
- d. Select "EXIT" and press the start button to return to the menu screen.

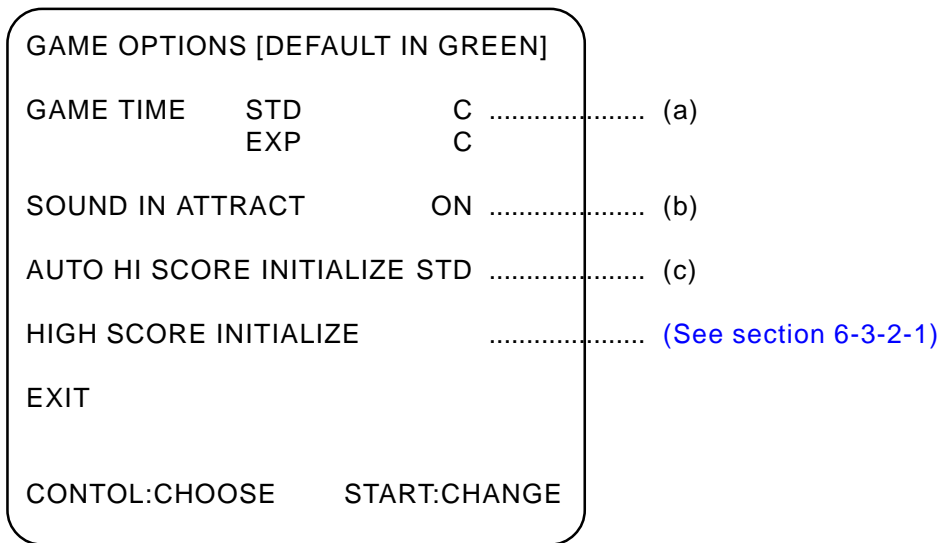

ITEM	DESCRIPTION	FACTORY SET
(a) Difficulty	A: No time limit. B: Long. C: Standard. D: Short.	B
(b) Attract Sound	ON: Attract sound ON. BGM: Only background music. EFFECT: Only sound effects. OFF: No sound.	ON
(c) High score initialize	STD: Performed for standard course only. EXP: Performed for expert course only. ON: Performed for both courses. OFF: Not performed.	STD

6-3-2-1 High Score Initialization

- a. Select "HIGH SCORE INITIALIZE" on the GAME OPTIONS screen and press the start button. The screen will change to the HIGH SCORE INITIALIZE screen.
- b. Move the Control Arm up or down to select the required item.
- c. The high score is initialized (reset) by pressing the start button, and the screen returns to the GAME OPTIONS screen.
- d. If "NO is selected and the start button pressed, nothing is reset and the screen returns to the GAME OPTIONS screen.

HI SCORE INITIALIZE	
NO Initialization not performed.
YES (STD) Only the standard course hi score is reset.
YES (EXP) Only the expert course hi score is reset.
YES (BOTH) The hi score for both courses are reset.

CONTROL:CHOOSE START;ENTER

6-3-3 I/O Test

- a. Select item (3) "I/O TEST" on the menu screen.
- b. Move the Control Arm up or down to select the required item.
- c. Press the start button to enter the selected test.
- d. Select "EXIT" and press the start button to return to the menu screen

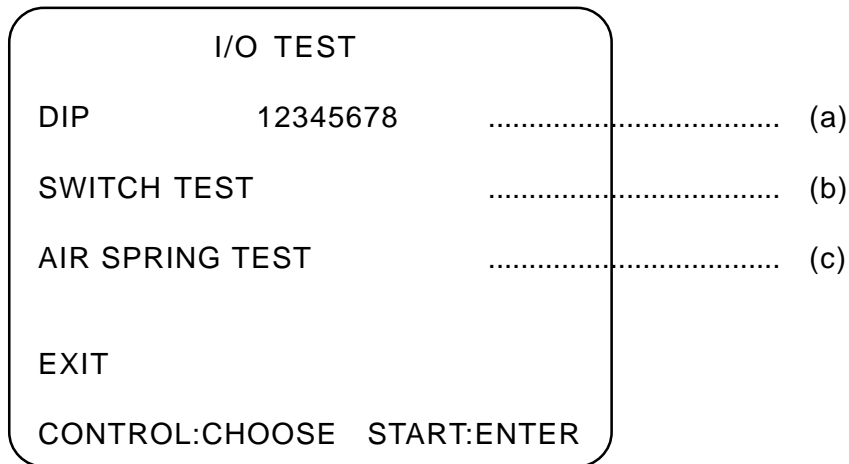

- (a) Displays the state of the PCB Dip switches, when a switch is ON the number is shown in red.
- (b) Tests the switches and control potentiometers. (See [6-3-3-1.](#))
- (c) Tests the air spring. (See [6-3-3-2.](#))

6-3-3-1 Switch Test

- a. Select "SWITCH TEST" on the menu screen and press the start button. The following screen is displayed.
- b. Operate the accelerator lever and start button together to return to menu screen

I/O TEST			
TEST SW		ON (a)
COIN SW		OFF (b)
SERVICE SW		OFF (c)
START BUTTON		OFF (d)
ACCEL LEVER	0000	0000	FREE (e)
SWING	0000	0000	CENTRE (f)
HANDLE POLE	0000	0000 (g)
START+LEVER:EXIT			

- (a) Test Switch: "ON" during test mode.
- (b) Coin Switch: 'OFF' will change to 'ON' when the coins to the correct game value have been inserted through the Cashflow acceptor or the coin switch is operated (S18 mech).
- (c) Service Switch 'OFF' will change to 'ON' each time the service switch is pressed.
- (d) Start button 'OFF' will change to 'ON' each time the start button is pressed. The button lamp will light each time the button is pressed.
- (e) Accelerator Lever 'FREE' will change to 'OK' each time the lever is operated fully.
- (f) Ship Swing 'CENTER' is displayed when in the central stand by position.
'RIGHT' and 'OK' is displayed when swung fully to the right.
'LEFT' and 'OK' is displayed when swung fully to the left.
- (g) Handle Pole 'UP OK' is displayed when the control arm is fully raised, "DOWN OK' is displayed when the control arm is fully lowered.

NOTE: If 'OK' does not appear when the ride is swung to its extreme travel, re-initialize the game as described in section 7

6-3-3-2 Air Spring Test

WARNING The ride moves during the Air Spring test. Ensure that hands and feet are clear before starting the test.

- a. Select 'AIR SPRING' test on the I/O TEST screen and press the start button. The following screen is displayed.
- b. Move the Control Arm up or down to select the required item.
- c. Press the start button to enter the selected test.
- d. Select "EXIT" and press the start button to return to the menu screen

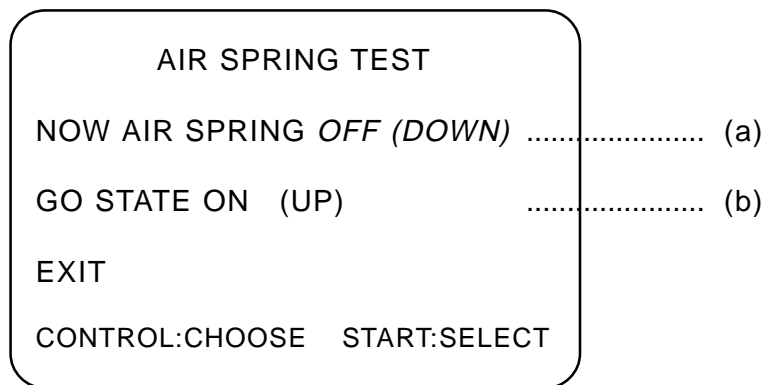

- (a) Displays the current position of the air spring.
- (b) Indicates the direction the air spring will move. Select 'GO STATE' and press the start button.
If the spring is UP it will go DOWN, and if the spring is DOWN it will go UP.

6-3-4 Monitor Test

- a. Select "MONITOR TEST" on the menu screen and press the start button. The following screen is displayed.
- b. Select an item by moving the control arm up or down. When the start button is pressed the screen will change to the selected pattern.
- c. To return to MONITOR TEST screen from a test pattern, press the start button.
- d. Select "EXIT" and press the start button to return to the menu screen

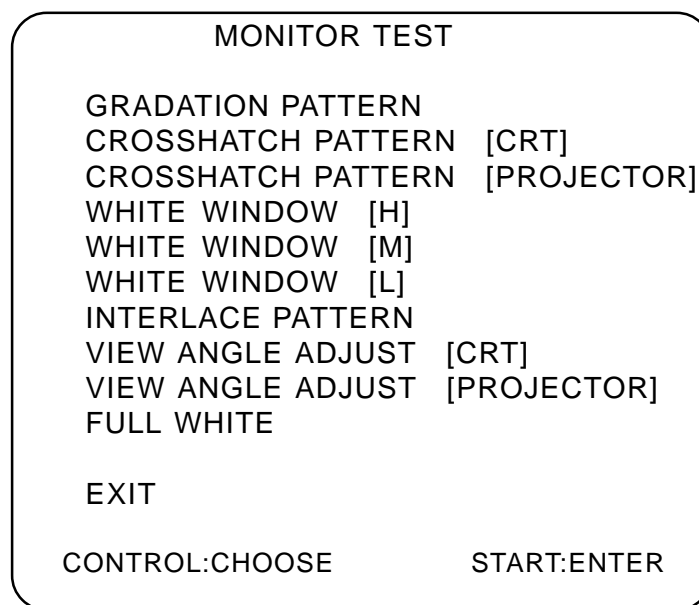

6-3-5 Sound Test

- a. Select "SOUND TEST " on the menu screen and press the start button. The following screen is displayed.
- b. Move the Control Arm up or down to select the required item.
- c. Press the start button to enter the selected test.
- d. Move the control arm up or down to alter the setting of the selected item.
- d. Select "EXIT" and press the start button to return to the menu screen

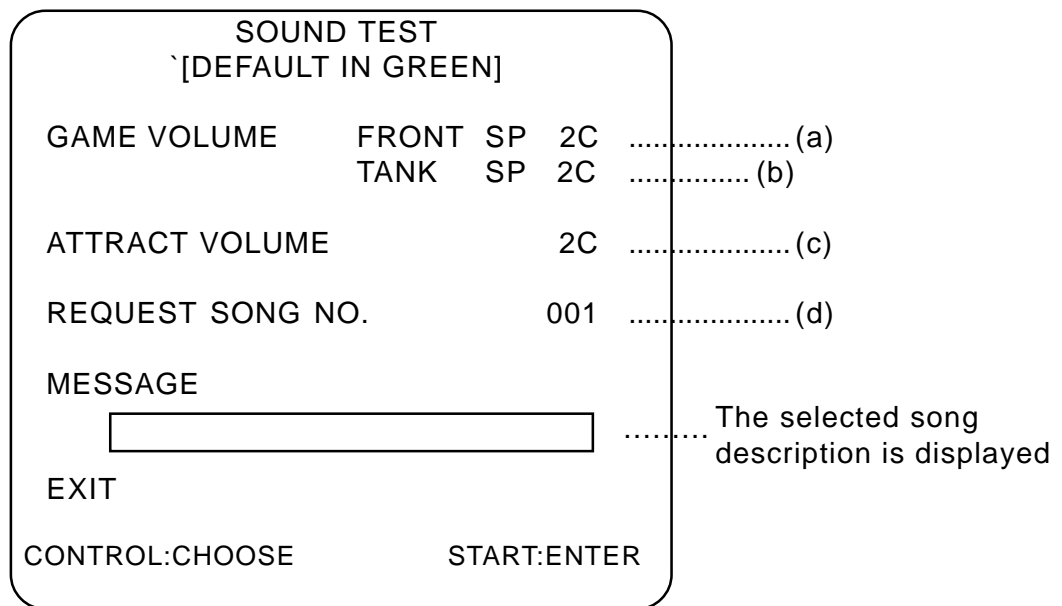

- | | |
|--------------------------|--|
| (a) Front speaker volume | Adjusts the volume of speakers in the header. |
| (b) Tank speaker volume | Adjusts the volume of the tank speaker on the ride. |
| (c) Attraction volume | Adjusts the volume during attract mode. |
| (d) Sound selection | Each digit of the REQUEST SONG No. can be changed by moving the control arm up or down. Each number will produce a different tune or sound when the start button is pressed. 001 will produce a stereo test. First a tone will be produced from the front speakers, then from the tank speaker and then from all speakers. |

6-3-6 ADS Data

Select "ADS DATA " on the menu screen and press the start button.

The book keeping data for the game will be displayed.

6-3-7 Others

Select "OTHERS" on the menu screen and press the start button.

This screen is used to test the PCB and to reset the game to factory settings.

7 INITIALIZATION

Adjustments When Replacing Parts (Initialization)

The following adjustments should always be performed after replacing the game PC board, ROM, or Control Pots.

The game will not operate correctly if these adjustments are not made.

- a) Ensure that Control Handle assembly and Ride assembly are in the neutral stand-by position.
- b) Slide the test switch "ON" while pressing the service switch. The following screen will be displayed on the monitor.

VOLUME INITIALIZE

TEST SW				<i>ON</i>
COIN SW				<i>OFF</i>
SERVICE SW				<i>OFF</i>
START BUTTON				<i>OFF</i>
ACCEL LEVER	<i>0000</i>	<i>0000</i>		
SWING	<i>0000</i>	<i>0000</i>		<i>CENTRE</i>
HANDLE POLE	<i>0000</i>	<i>0000</i>		<i>UP</i>

START:HANDLE POLE ADJUST

- c) At this time the Ride assembly and Accelerator lever are initialized.
- d) Press the start button to initialize the Control Arm. The following screen will be displayed.

HANDLE POLE ADJUST

		<i>UP</i>	<i>DOWN</i>
HANDLE POLE	<i>0000</i>	<i>0000</i>	

PLEASE MAKE HANDLE POLE
UP/DOWN TO ADJUST!

- e) Move the Control Arm UP and DOWN through its full range of movement. This motion will be registered as the motion range of the Control Arm.
- f) Slide the test switch "OFF" to return to normal game mode.

8. REMOVING AND REPLACING ASSEMBLIES AND PARTS.

WARNING

- Adjustments or maintenance on this machine should be carried out by qualified personnel only.
- Do not make any alterations to this machine without prior approval. Doing so could cause unforeseeable danger.
- Only parts specified by Namco Europe Ltd. should be used when replacing or repairing parts (including screws).
- Ensure that power to the machine is turned OFF before commencing any maintenance work (troubleshooting, repairs etc.)
- If performing work not described in this manual, be sure to contact your distributor for instructions as no responsibility will be accepted for damage or injury.
- Parts of the power supply, projector monitor and air compressor remain hot or carry high voltage even after switching OFF and could cause burns or electric shock. Take care not to touch these parts accidentally.
- Make sure that the machine is switched OFF before connecting or disconnecting any plugs or connectors.
- When removing the mains connector from the machine, or the mains plug from the wall outlet, always grasp the plug not the cable.

8-1 COMPRESSOR ASSEMBLY

NOTE:

There are no user serviceable parts on the compressor assembly.

Under no circumstances should any regulator valves be adjusted. Altering the regulator valves could lead to serious damage to the system or injury to personnel

WARNING

- Parts of the compressor become very hot during use. Take care not to touch the compressor when it is hot.

8-2 Ride Assembly

8-2-1 Replacing the Swing Potentiometer

- WARNING**
- Make sure that the power is turned OFF before commencing any work.
 - Do not let any one get on the ride assembly while replacing the potentiometer to prevent injury by trapped hands or fingers.

- 1) Remove the two pozi head screws (with flat and spring washers)(M5x10) and remove the potentiometer cover.
- 2) Remove the two pozi head screws (with flat and spring washers)(M5x10) and remove the maintenance cover.

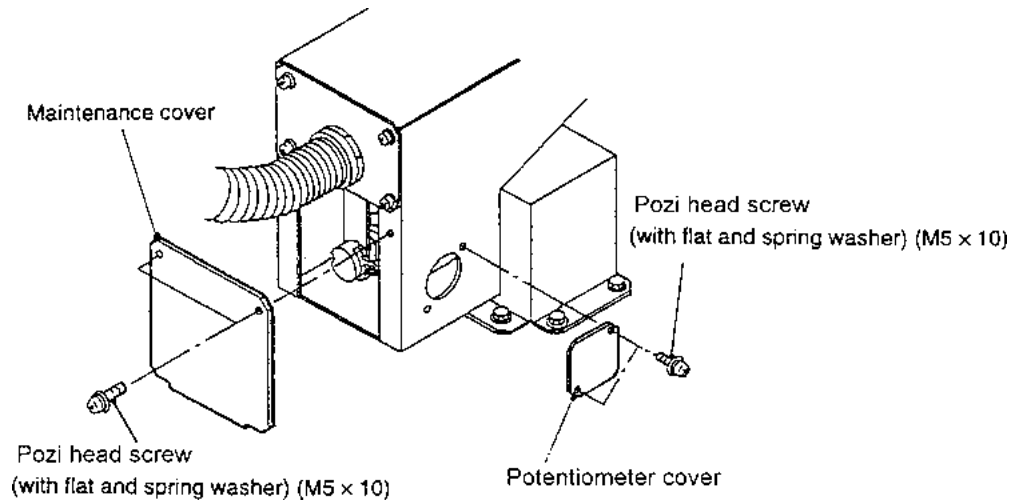

- 3) Disconnect the connector. Loosen the grub screw (M4x12) and remove the potentiometer complete with its mounting bracket.

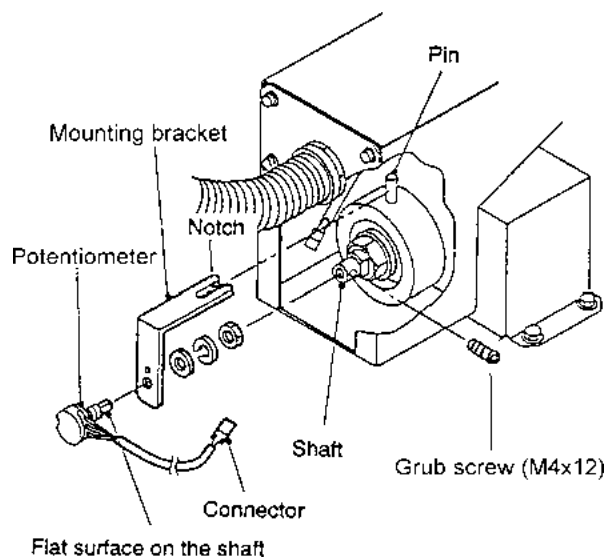

- 4) Remove the potentiometer from the mounting bracket and replace with a new potentiometer.
- 5) Re-assemble in reverse order.

NOTE: When refitting the potentiometer and bracket ensure that the grub screw engages on the flat of the potentiometer shaft, and the notch in the mounting bracket engages on the pin.

- 6) **Re-initialize the game.** ([Refer to section 7 'Initialization'](#))

8-2-2 Removing the Tank

WARNING • Make sure that the power is turned OFF before commencing any work.

- 1) Remove the four security screws (M5x12) and four security screws (M5x20), and remove the tank.
- 2) Re-assemble in reverse order.

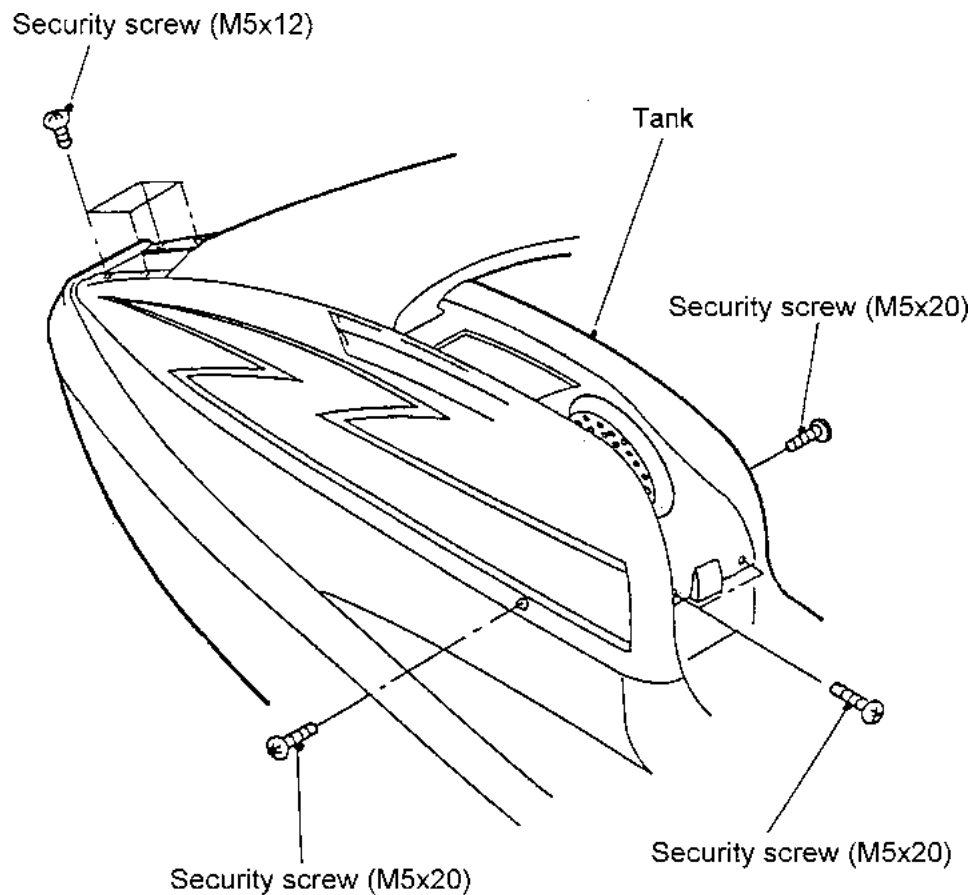

8-2-3 Replacing Solenoid Valve A

WARNING • Make sure that the power is turned OFF before commencing any work.

- 1) Remove the tank. (Refer to section 8-2-2 'Removing the Tank')
- 2) Disconnect the connector.
- 3) Push the blue release of the elbow union in, and while holding it in, pull out the air tube. (There will be a loud noise as the air pressure is released.)
- 4) Remove the two pozi head screws (M4x35) and remove the solenoid valve A.
- 5) Remove the elbow union, half union and silencer from the removed solenoid valve, and install them on to the new solenoid valve.
- 6) Re-assemble in reverse order. (The air tube is just a push fit.)

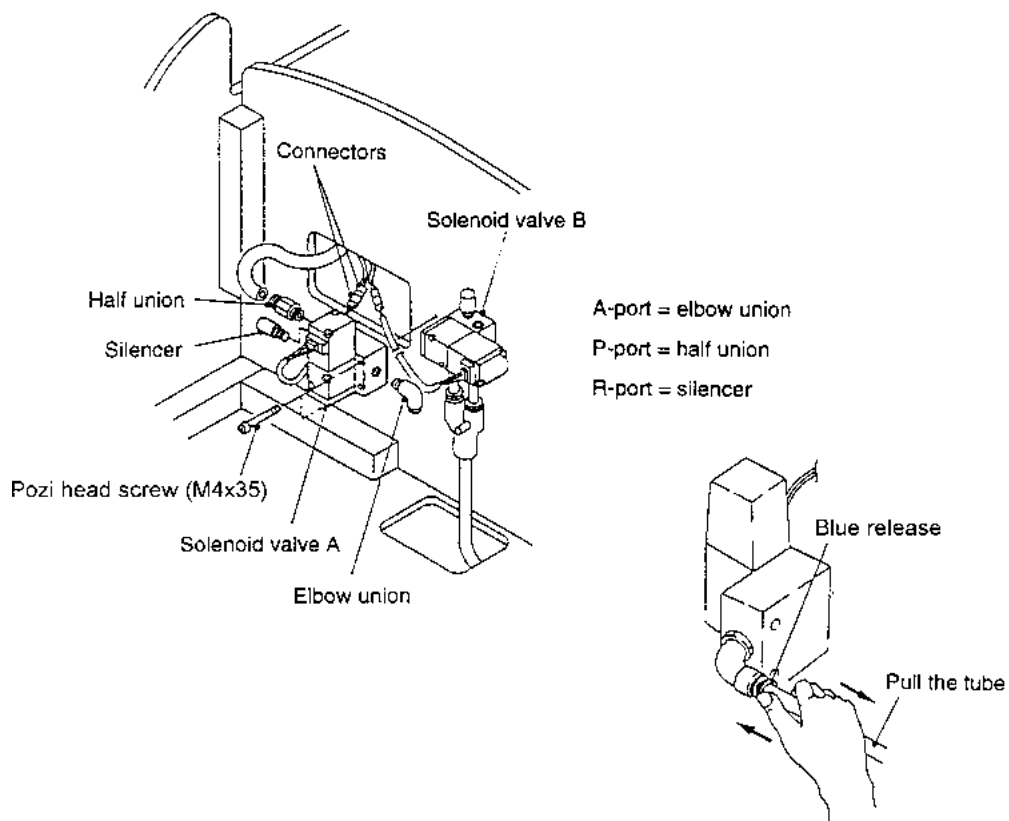

NOTE:

- Take care that no dirt or other matter gets in to the air tube while it is disconnected.
- After refitting the air tube, give it a gentle pull to ensure that it is connected properly and will not come loose.

8-2-4 Replacing Solenoid Valve B

WARNING • Make sure that the power is turned OFF before commencing any work.

- 1) Remove the tank. (Refer to section 8-2-2 'Removing the Tank')
- 2) Disconnect the connector.
- 3) Push the blue release of the elbow union in, and while holding it in, pull out the air tube. (There will be a loud noise as the air pressure is released.)
- 4) Remove the two pozi head screws (M4x35) and remove the solenoid valve B.
- 5) Remove the half union, taper-screw plug and silencer from the removed solenoid valve, and install them on to the new solenoid valve.
- 6) Re-assemble in reverse order. (The air tube is just a push fit.)

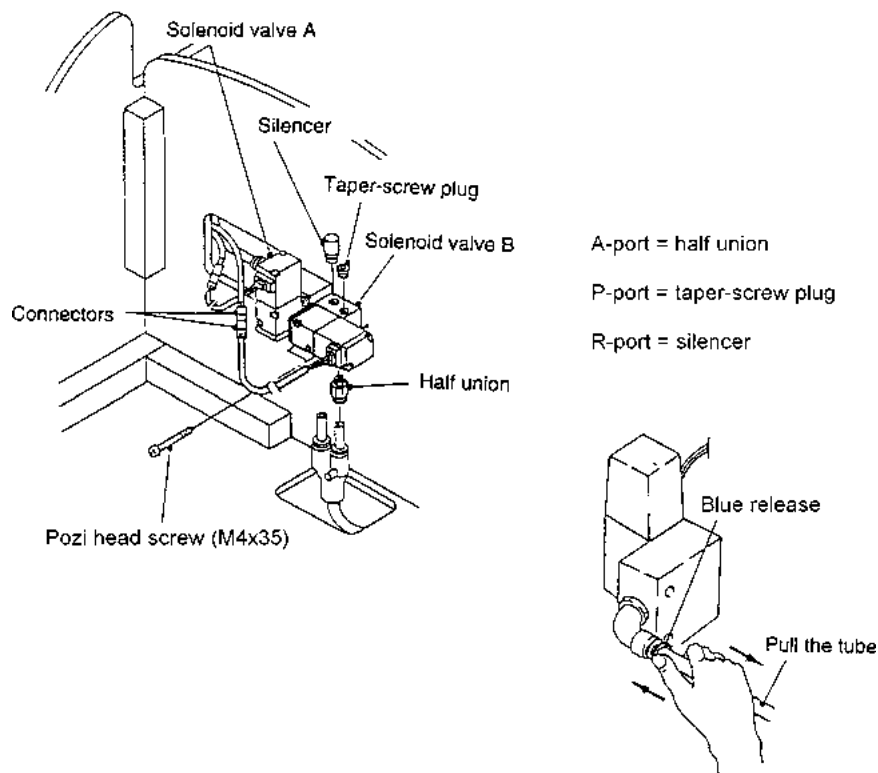

NOTE:

- Take care that no dirt or other matter gets in to the air tube while it is disconnected.
- After refitting the air tube, give it a gentle pull to ensure that it is connected properly and will not come loose.

8-3 Control Arm Assembly

8-3-1 Replacing the Accelerator Potentiometer

WARNING • Make sure that the power is turned OFF before commencing any work.

- 1) Remove the four security screws (M5x12) and remove the accelerator cover.

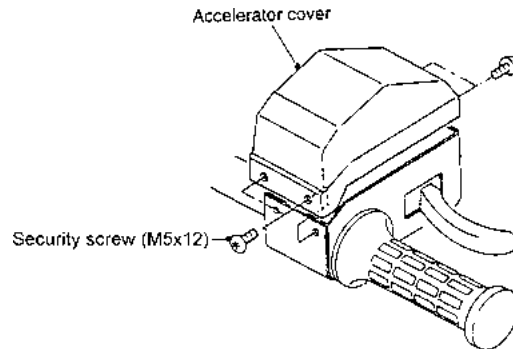

- 3) Disconnect the connector. Loosen the grub screw (M3x5) and remove the potentiometer complete with its mounting bracket.
- 4) Remove the potentiometer from the mounting bracket and replace with a new potentiometer.
- 5) Re-assemble in reverse order.

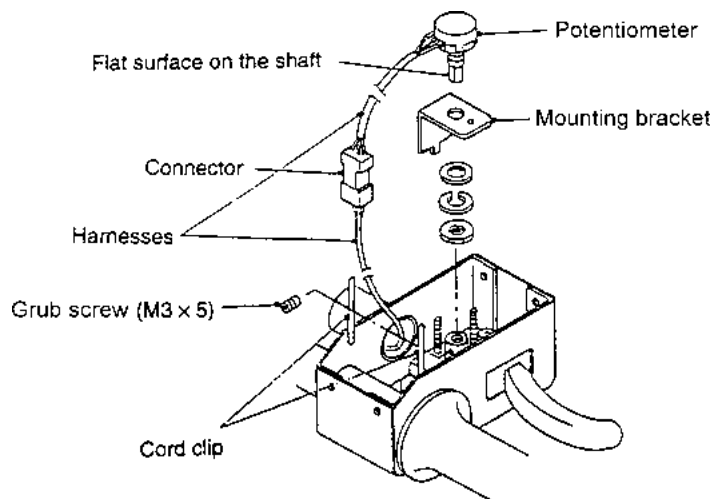

NOTE: When refitting the potentiometer and bracket ensure that the grub screw engages on the flat of the potentiometer shaft, and the wire harness is secured with the two cord grips so that it does not get caught or pinched by the moveable section.

- 6) **Re-initialize the game.** (Refer to section 7 'Initialization')

8-3-2 Replacing the Control Arm Potentiometer

WARNING • Make sure that the power is turned OFF before commencing any work.

- 1) Remove the tank. (Refer to section 8-2-2 'Removing the Tank').
- 3) Disconnect the connector. Loosen the grub screw (M4x5) and remove the potentiometer complete with its mounting bracket.
- 4) Remove the potentiometer from the mounting bracket and replace with a new potentiometer.
- 5) Re-assemble in reverse order.

NOTE: When refitting the potentiometer and bracket ensure that the grub screw engages on the flat of the potentiometer shaft, and the lug on the mounting bracket engages in the slot of the main metalwork.

- 6) **Re-initialize the game.** (Refer to section 7 'Initialization')

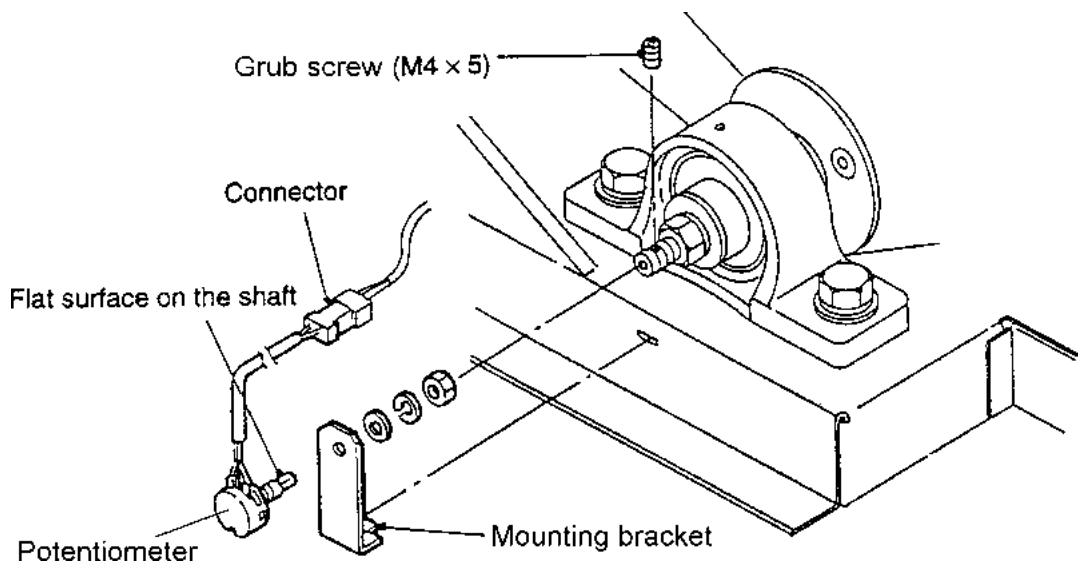

8-3-3 Replacing the Start Switch or Lamp

WARNING • Make sure that the power is turned OFF before commencing any work.

- 1) Remove the eight security screws (M5x12) and lift the top vac-form sufficiently to remove the switch and lamp from the push button.
- 2) Remove the top vac-form.
- 3) Replace the lamp or switch.
- 4) Re-assemble in reverse order.

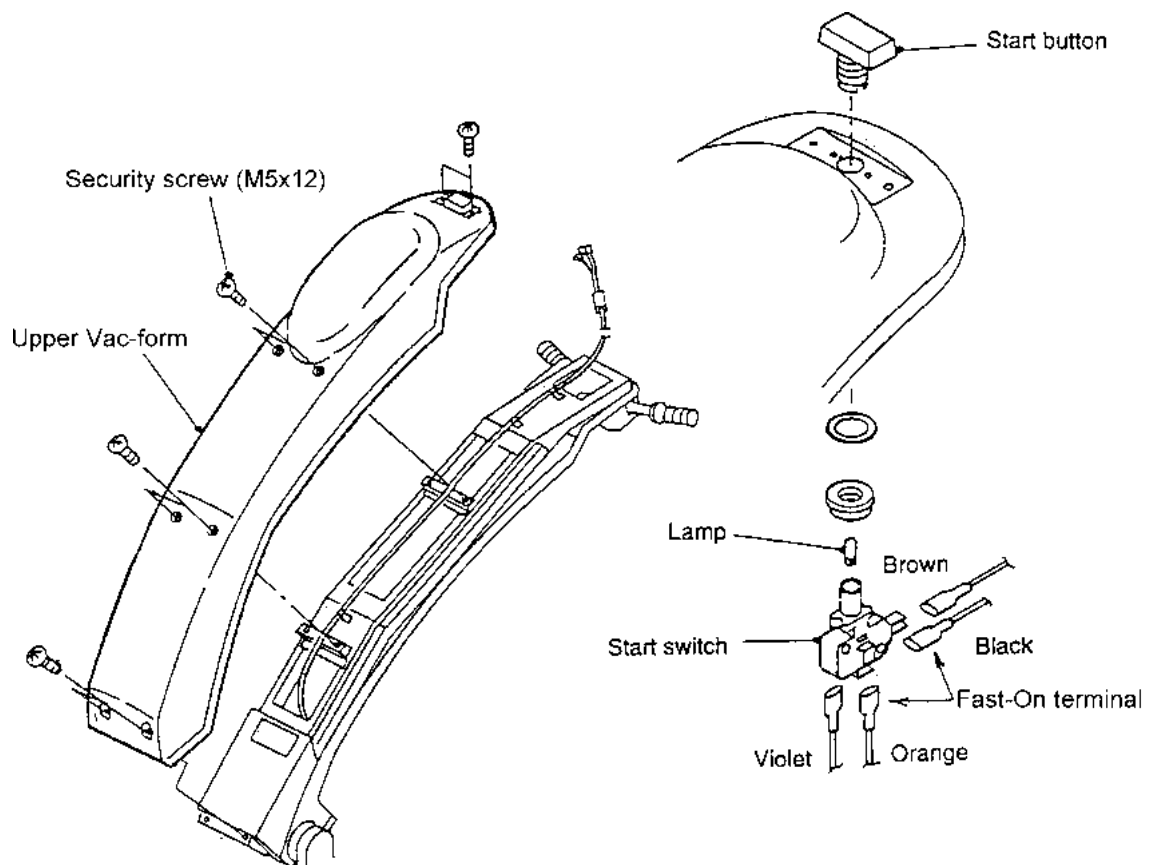

8-4 Header Assembly

8-4-1 Replacing the Fluorescent Lamp or Starter

- WARNING** • Make sure that the power is turned OFF before commencing any work.
- WARNING** • The Header Assembly is very high, and it is important that a means of reaching the height safely, without stretching, is available. (e.g. steps, step stools etc.)
- WARNING** • The fluorescent lamp may be hot, take care when handling.

- 1) Remove the four security screws (M5x20), and remove the acrylic sign board.
- 2) Replace the fluorescent lamp or starter.
- 3) Re-assemble in reverse order.

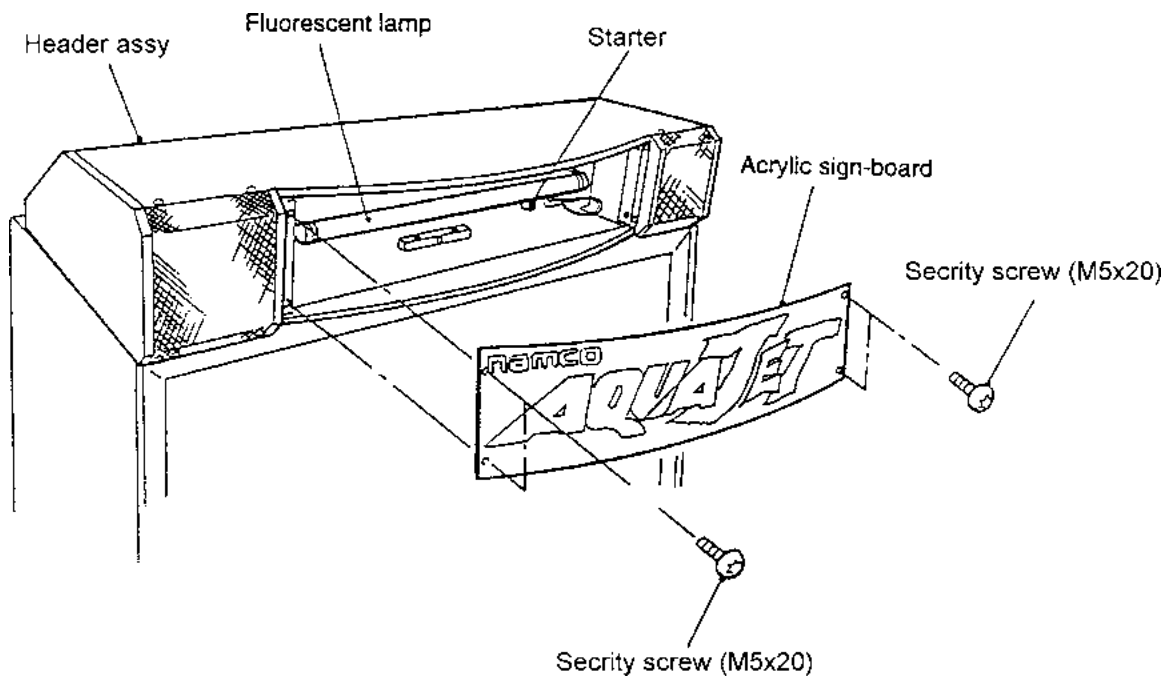

9. PARTS

Header Assy

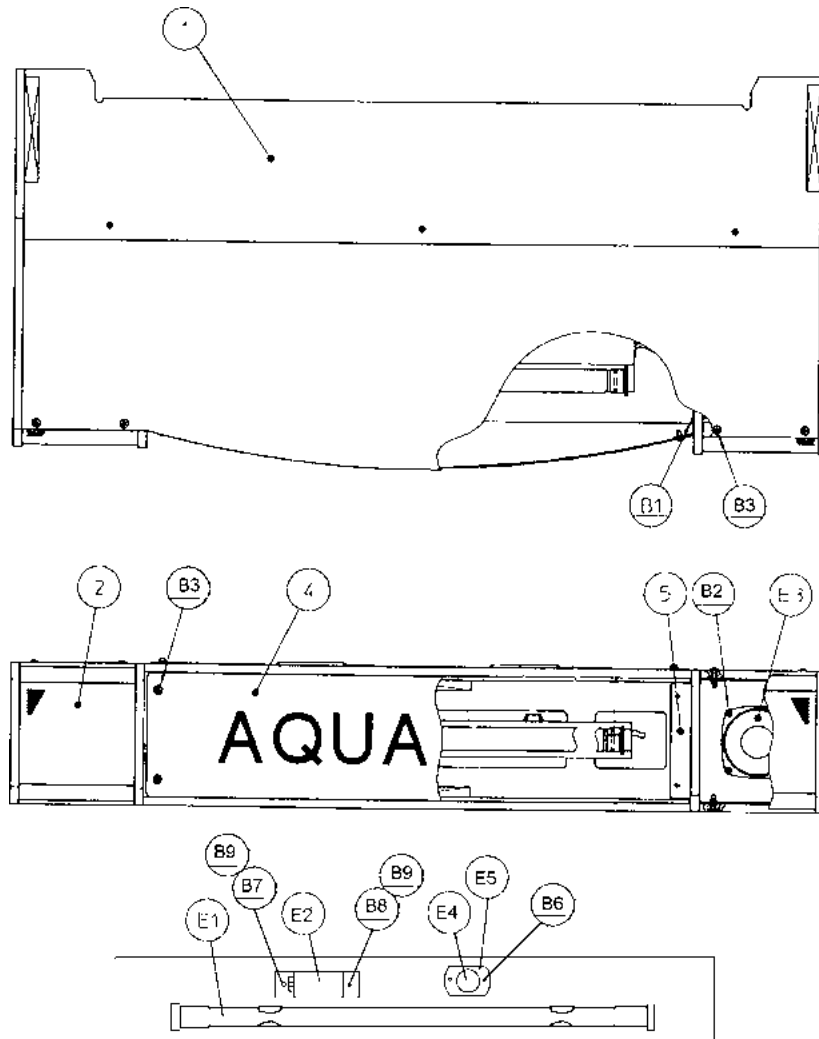

ITEM	DESCRIPTION	PART No
1	HEADER CABINET	37100110
2	LOUDSPEAKER GRILLE	46000083
4	HEADER ACRYLIC	30000234
5	ACRYLIC RETAINING BRACKET	46000084
E1	FLOURESCENT TUBE 18" 15W	64500009
E3	LOUDSPEAKER 5½" FULL RANGE	62000065
E4	STARTER 240v 4-80W UNIVERSAL	63000000
E5	STARTER HOLDER	64800001
B1	M6x16 HEX HEAD SET SCREW - BZP	26500311
	M6 SPRING WASHER - BZP	28000028
	M6 FLAT WASHER - BZP	28000166
B2	M4x16 PZ PAN HEAD - BLACK	26300294
	M4 SPRING WASHER - BLACK	28000127
	M4 FLAT WASHER - BLACK	28000132
B3	M5x20 SECURITY BUTTON HEAD - SUS	26300039
B6	No4x½" PZ PAN HEAD WOODSCREW - BZP	26100070
B7	M4x12 PZ PAN HEAD - BZP	26300057
B8	M4x16 PZ PAN HEAD - BZP	26300383
B9	M4 WHIZZTITE NUT - YEL ZNC	27000128

Coin Tower

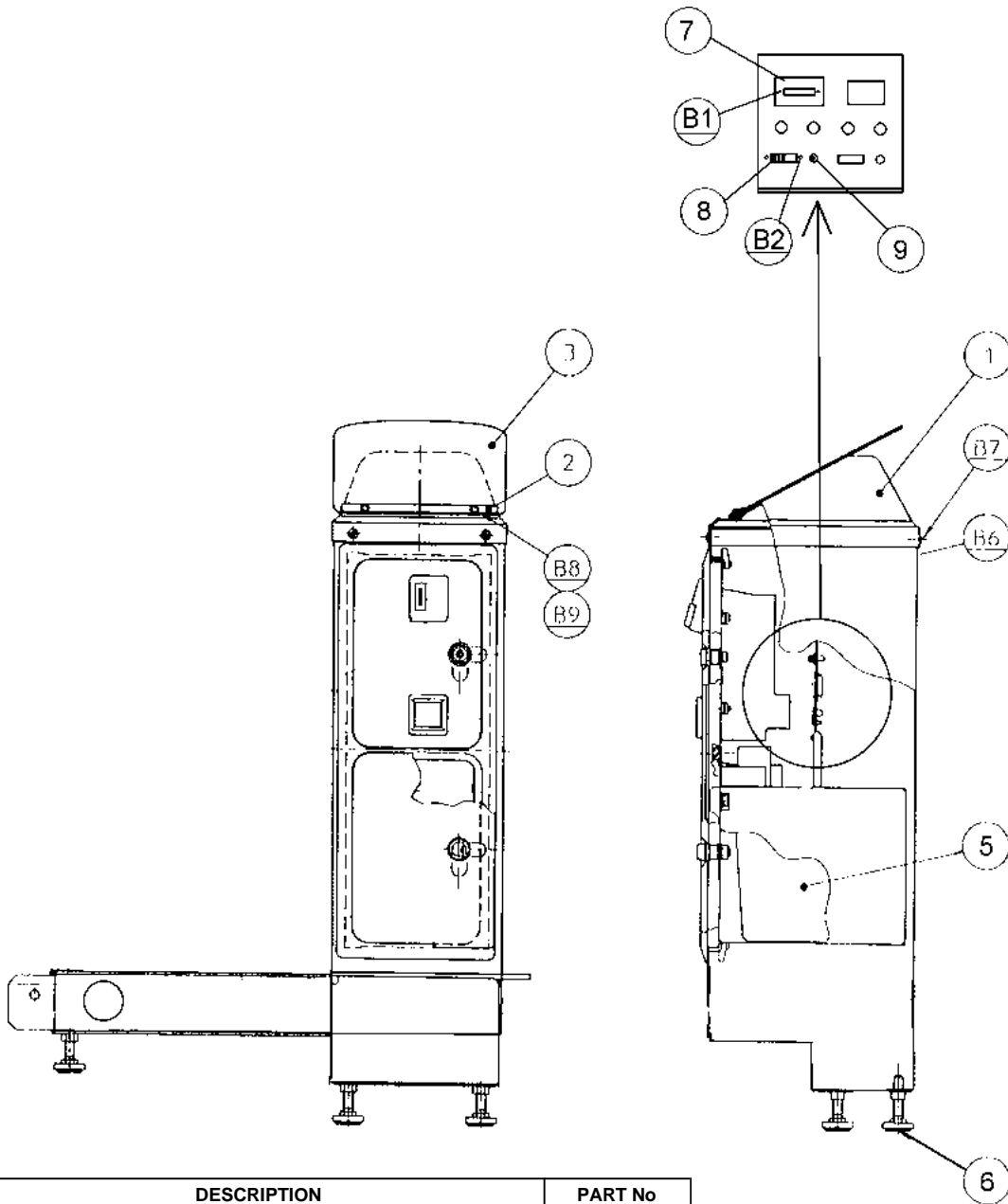

ITEM	DESCRIPTION	PART No
1	COIN TOWER TOP VAC-FORM	46000057
2	INSTRUCTION DECAL SUPPORT BRACKET	46000146
3	PLAY INSTRUCTION DECAL - ACRYLIC	30000235
5	WOODEN CASHBOX	37100093
6	M12 ADJUSTABLE FOOT	88300311
7	3.5-6v METER - PANEL MOUNT	65000002
8	MINIATURE SLIDE SWITCH - DPCO	60000023
9	SERVICE SWITCH 7mm RED - F424	60000059
B1	No8x½" PZ CSK WOODSCREW - BZP	26100265
B2	M3x10 PZ PAN HEAD - BZP	26300067
B7	M5x16 SECURITY BUTTON HEAD - SUS	26300032
B8	M5x20 SECURITY BUTTON HEAD - SUS	26300039
B9	M5x14 RAWLNUT	27000153

Cabinet Base

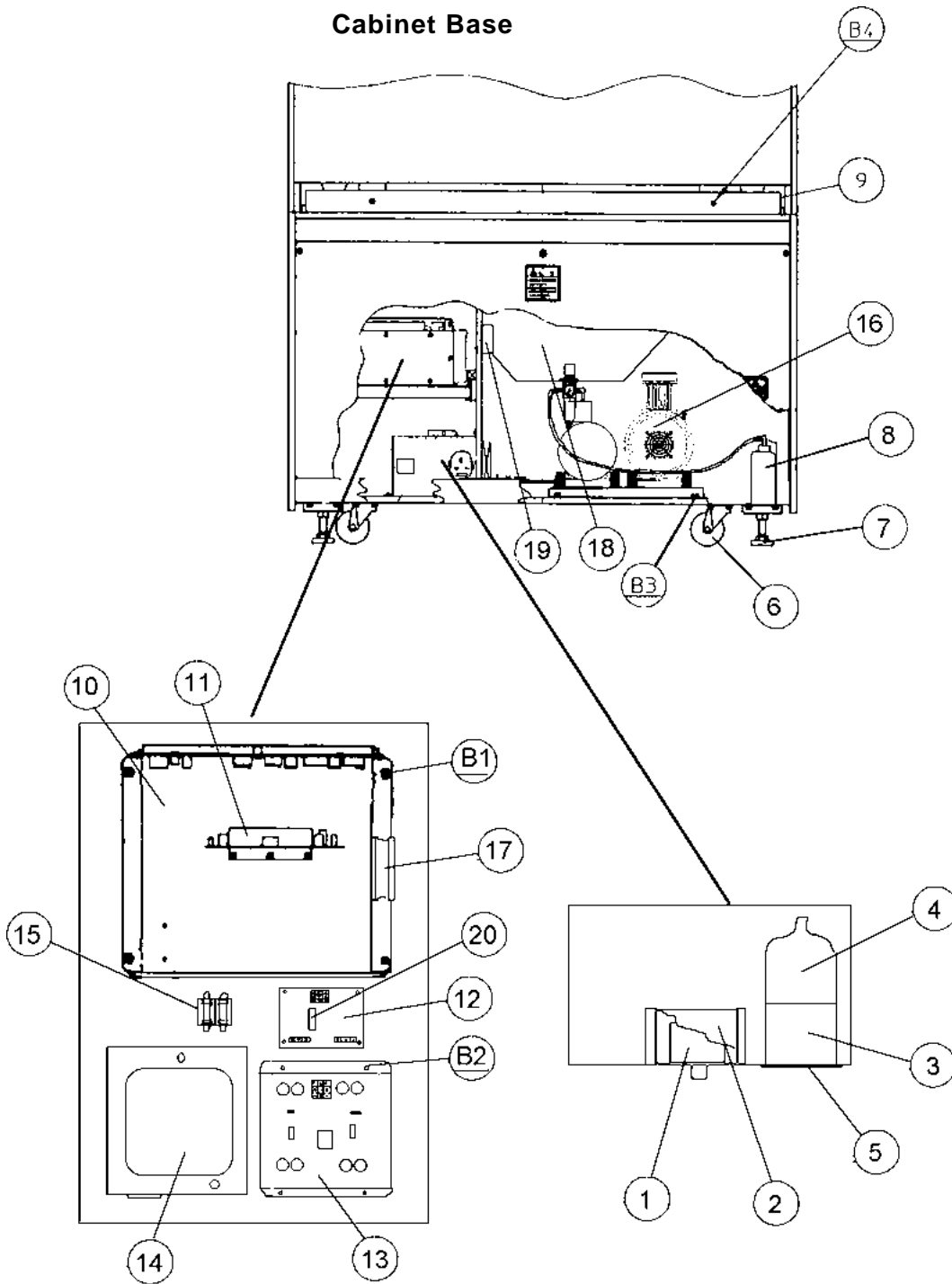

ITEM	DESCRIPTION	PART No
1	INTERLOCK SWITCH	6000006
2	INTERLOCK SWITCH COVER	39000028
3	SCHAFFNER 10A DOUBLE FUSED MAINS IN FILTER	62500011
4	SHAFFNER BOOT 1B3	66000017
5	10A 20mm FUSE	63500705
6	SWIVEL CASTOR 75mm	59000005
7	M16 ADJUSTABLE FOOT	88300079
8	CONDENSATE BOTTLE 0.5ltr	46000079
9	WOODEN BLANKING STRIP	37100109
10	AQUA JET SUPER SYSTEM 22 PCB ASSY	XAJ-PCB
11	4 CHANNEL AMP PCB - SUPER SYSTEM 22	XCYB-AMPCB
12	LAMP DRIVER PCB - SINGLE CHANNEL	46000020
13	3 CHANNEL AMPLIFIER - Ver3	46000036
14	ASTEC SA301-3400 SMPSU 5v 30A	83000001

ITEM	DESCRIPTION	PART No
15	FUSE - 1/4" 1A QB	63500424
16	COMPRESSOR ASSY - TYPE 600 W/Low READ GAUGE	46000058
17	FAN 230v 4 1/2"	67000015
18	ROTARY FAN	45000940
19	PLASTIC STARTER CAPACITOR	46000041
20	SSR	46000164
B1	M5x20 PZ PAN HEAD - BZP	26300576
	M5 SPRING WASHER - BZP	28000145
	M5 FLAT WASHER - BZP	28000144
B2	M4x20 PZ PAN HEAD - BZP	26300055
	M4 SPRING WASHER - BZP	28000035
	M4 FLAT WASHER - BZP	28000036
B3	M8x25 HEX HEAD SET SCREW - BZP	26300050
	M8 SPRING WASHER - BZP	28000176
	M8 FLAT WASHER - BZP	28000175
B4	M5x30 PZ PAN HEAD - BZP	26300595

Cabinet

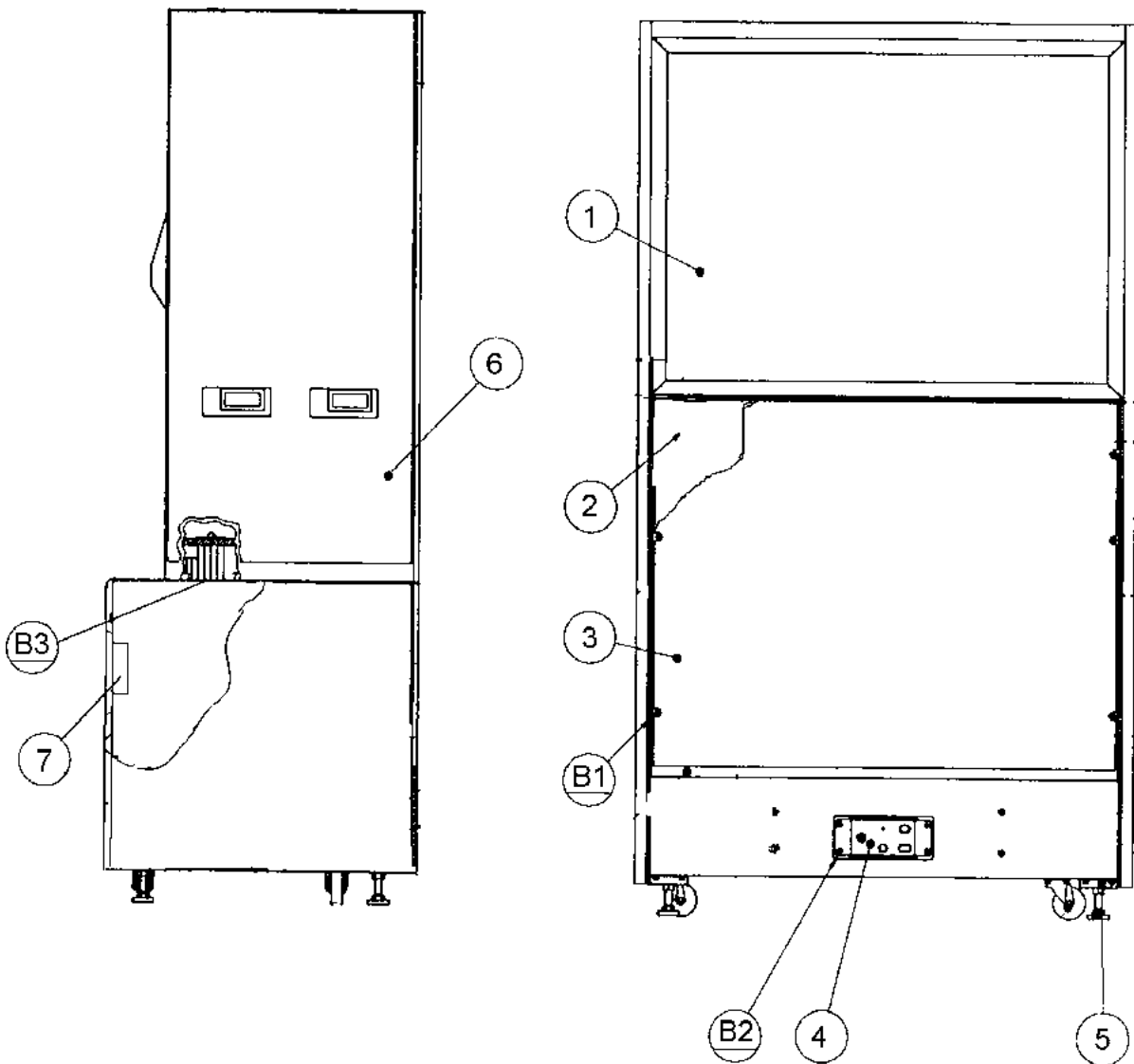

ITEM	DESCRIPTION	PART No
1	PIONEER REAR PROJECTION MONITOR 230v	84000028
2	CABINET FRONT PANEL	37100106
3	LOUDSPEAKER GRILLE	45000701
4	HARNESS CONNECTOR BRACKET	46000082
5	ADJUSTABLE FOOT MOUNTING BRACKET	45000204
6	SIDE DECAL - LHS/RHS	40000381
7	FAN 4½" 230v	67000015
8	FRONT DECAL	40000383
9	LOUDSPEAKER 6½" - BASS	62000068
B1	M5x30 SECURITY BUTTON HEAD - SUS	26300036
	M5x25 PZ PAN HEAD - BZP	26300049
B2	M5 SPRING WASHER - BZP	28000144
	M5 FLAT WASHER - BZP	28000145
	M10x130 HEX HEAD SET SCREW - BZP	26500475
B3	M10 SPRING WASHER - BZP	28000023
	PIONEER CLAMP WASHER	46000163

Control Arm

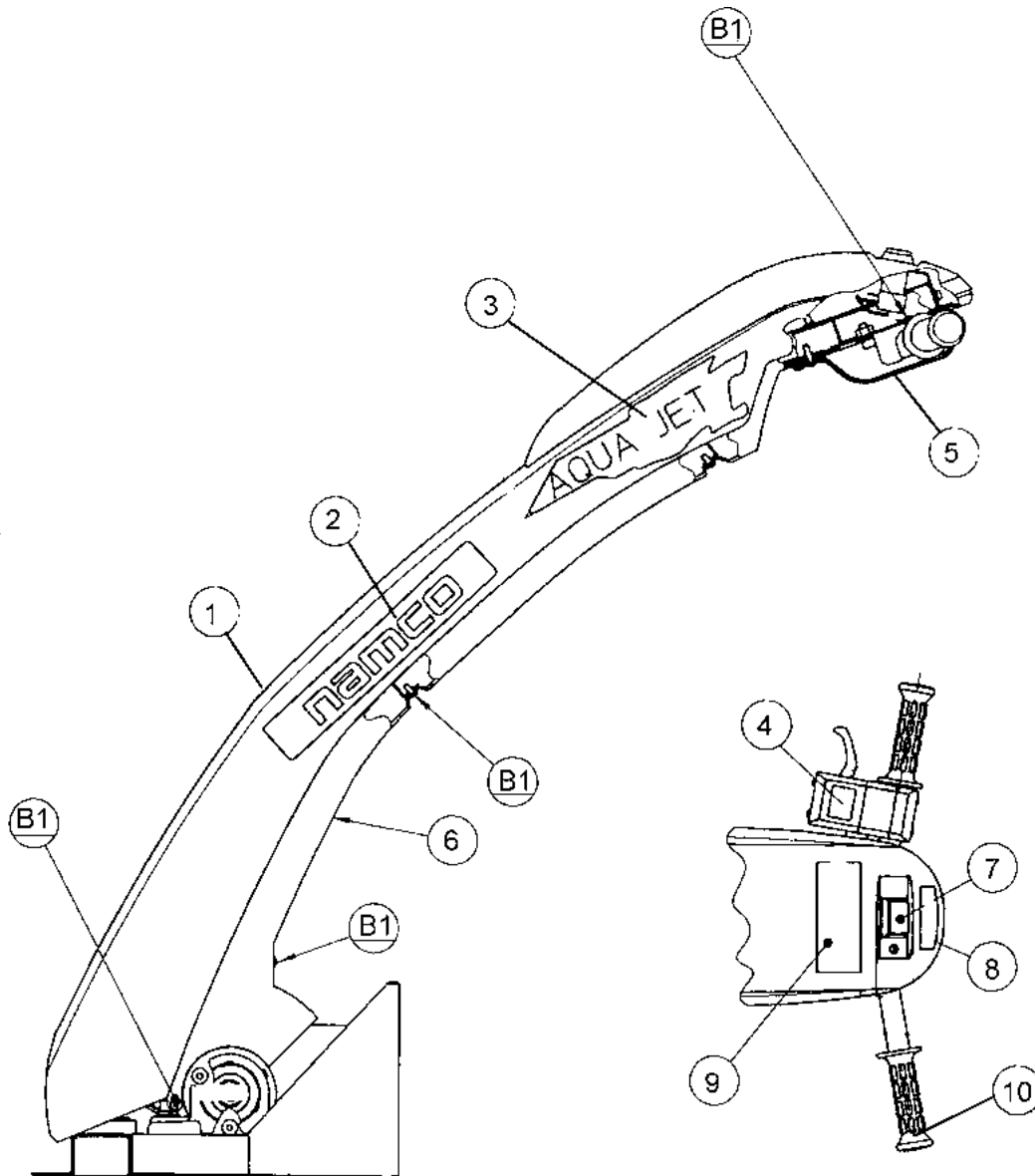

ITEM	DESCRIPTION	PART No
1	CONTROL ARM TOP VAC-FORM	46000054
2	NAMCO DECAL	40000390
3	AQUAJET DECAL	40000389
4	ACCELERATOR DECAL	40000392
5	HANDLEBAR COVER VAC-FORM	46000055
6	CONTROL ARM BOTTOM VAC-FORM	46000053
7	RPB RECTANGULAR PUSH BUTTON - YELLOW "START"	60500044
8	START DECAL	40000391
9	WARNING DECAL	40000393
10	HANDLEBAR GRIP - LHS/RHS	46000141
B1	M5x16 SECURITY BUTTON HEAD - SUS	26300032

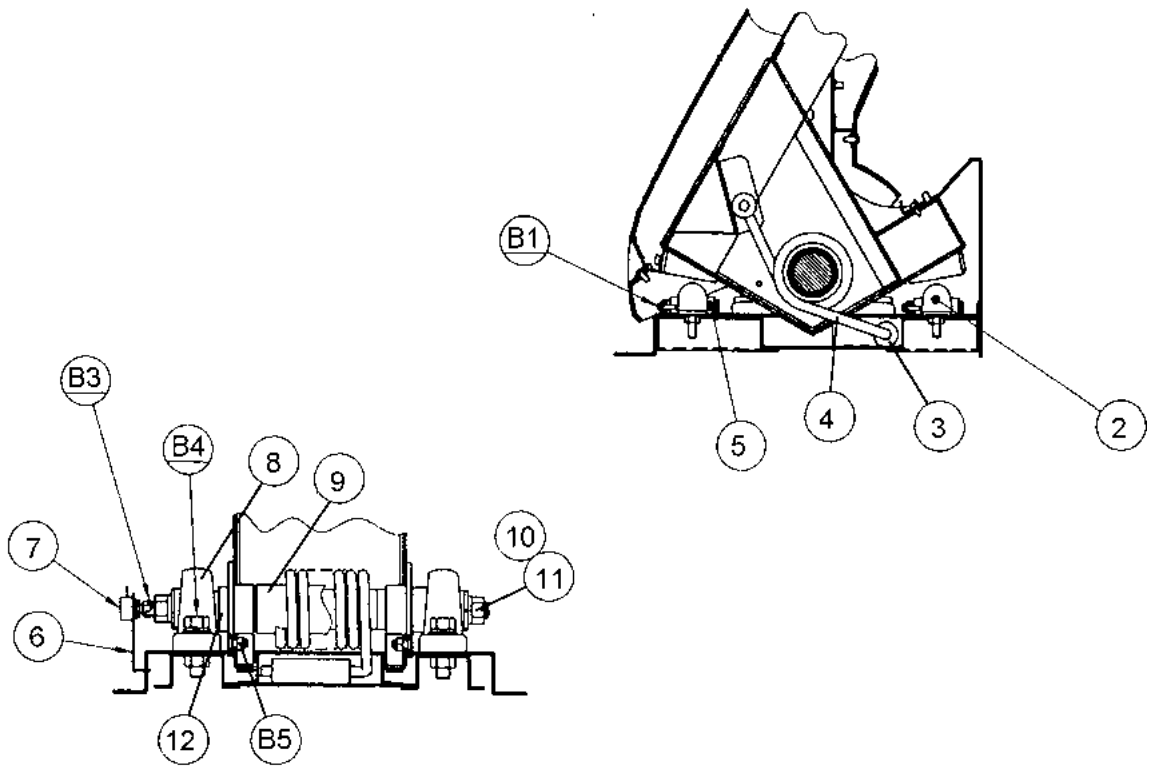

ITEM	DESCRIPTION	PART No
2	RUBBER STOPPER RI-30	46000007
3	PITCH SPRING BUMPER	46000075
4	PITCH SPRING	46000073
5	PITCH STOPPER RUBBER BLOCK	46000072
6	PITCH POTENTIOMETER MOUNTING BRACKET	46000132
7	PITCH POTENTIOMETER	X008-021
8	BEARING UCP-206-NSK	46000080
9	SPRING SLEEVE	46000131
10	M16 FULL NUT - BZP	27000205
	M16 SPRING WASHER - BZP	28000301
11	BEARING SECURING WASHER 40 OD x 17 ID x 3.2T	46000133
12	BEARING SPACER	46000130
13	PITCH MAIN SHAFT	46000129
B1	M4x12 PZ PAN HEAD - BZP	26300057
	M4 SPRING WASHER - BZP	28000035
	M4 FLAT WASHER - BZP	28000036
B3	M4x8 HEX SOCKET SET SCREW - BZP	26300083
B4	M14x50 HEX HEAD SET SCREW - BZP	26500502
	M14 SPRING WASHER - BZP	28000302
	M14 FLAT WASHER - BZP	28000021
B5	M8x20 SOCKET HEAD CSK SCREW - BZP	26300862

Accelerator

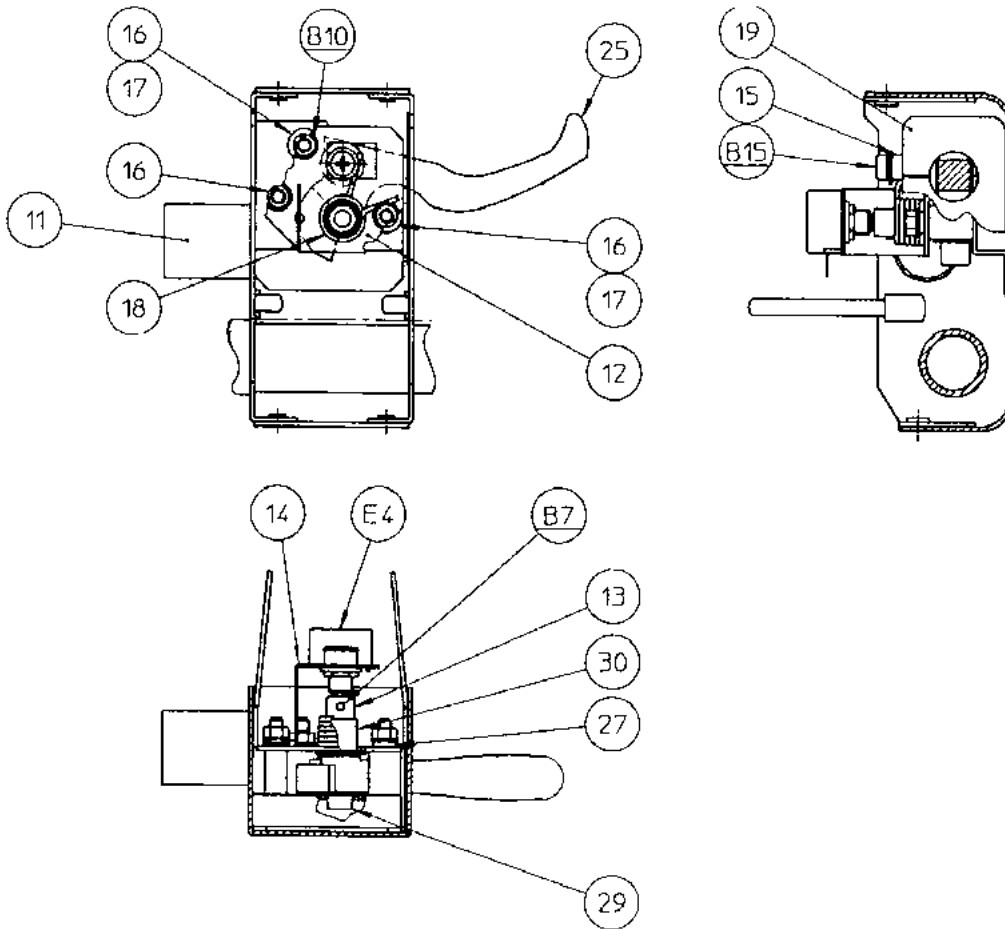

ITEM	DESCRIPTION	PART No
11	HANDLEBAR METALWORK	46000134
12	ACCELERATOR PLATE	46000135
13	ACCELERATOR POTENTIOMETER SHAFT	46000136
14	ACCELERATOR POTENTIOMETER BRACKET	46000137
15	ACCELERATOR SPRING STOP PIN	46000138
16	ACCELERATOR LIMIT STOP TUBE	46000139
17	ACCELERATOR LIMIT STOP BUMPER	46000074
18	ACCELERATOR SPRING	46000157
19	ACCELERATOR SLIDE COVER	46000140
25	ACCELERATOR HANDLE	46000076
27	SPACER - 8mm OD x 3mm LONG	46000142
29	OILITE BUSHING LFF 0705	46000077
30	OILITE BUSHING LFF 1012	46000078
E4	ACCELERATOR POTENTIOMETER	X008-021
B7	M3x5 HEX SOCKET SET SCREW - BZP	26300111
B10	M5 WHIZZTITE NUT - BZP	27000151
B15	M5x8 PZ PAN HEAD - BZP	26300570
	M5 SPRING WASHER - BZP	28000144
	3/16" x 3/4" FLAT WASHER - BZP	28000224

Ride Assy

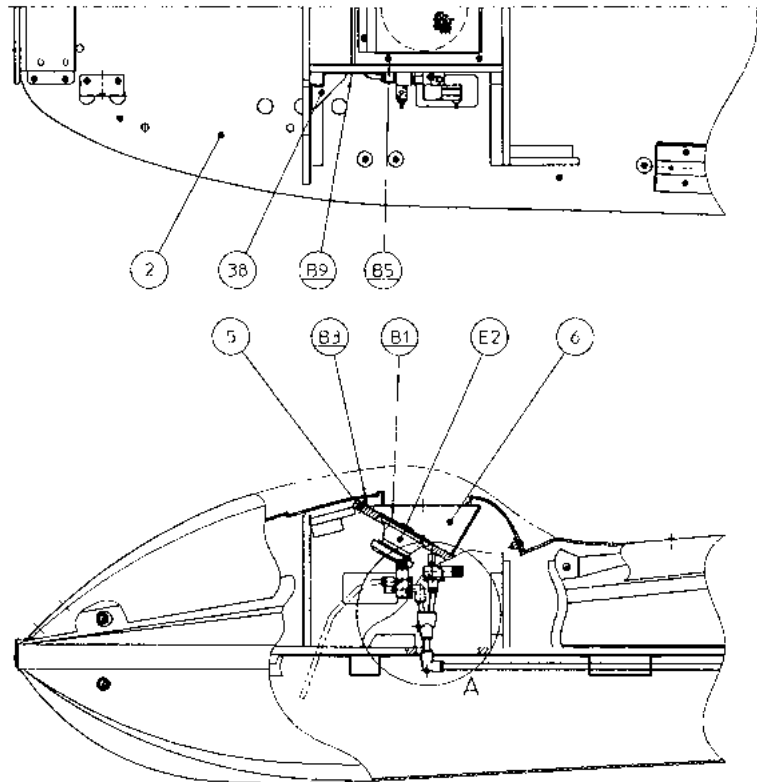
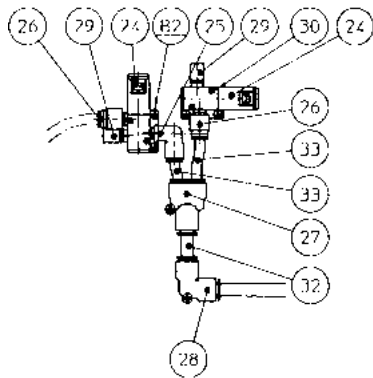

ITEM	DESCRIPTION	PART No
2	RIDE STAND-ON WOODEN PLATE	37100111
5	LOUDSPEAKER MOUNTING WOOD	37100112
6	LOUDSPEAKER MESH	46000120
24	AIR VALVE VK334-6GS-01 12vDC	46000069
25	CONNECTOR KQL08-01S	46000147
26	CONNECTOR KQH08-01S	46000148
27	CONNECTOR KQU08-10	46000149
28	CONNECTOR KQL10-00	46000150
29	AN103-01	46000126
30	PLUG 1/8	46000167
32	TUBE TU1065B 50mm	46000151
33	TUBE TU0805B 55mm	46000155
38	CONTROL ARM WOOD SUPPORT BRACKET	46000162
E2	LOUDSPEAKER 5½" FULL RANGE	62000065
B1	M4x20 PZ PAN HEAD - BLACK	26300391
	M4 SPRING WASHER - BLACK	28000127
	M4 FLAT WASHER - BLACK	28000132
B2	M4x40 PZ PAN HEAD - BZP	26300443
	M4 SPRING WASHER - BZP	28000035
B3	M5x16 PZ PAN HEAD - BZP	26300580
	M5 SPRING WASHER - BZP	28000144
	M5 FLAT WASHER - BZP	28000145
B5	M5x35 PZ PAN HEAD - BZP	26300613
	M5 SPRING WASHER - BZP	28000144
	M5 FLAT WASHER - BZP	28000145
B9	No6x½" PZ FLANGE - BZP	26100074

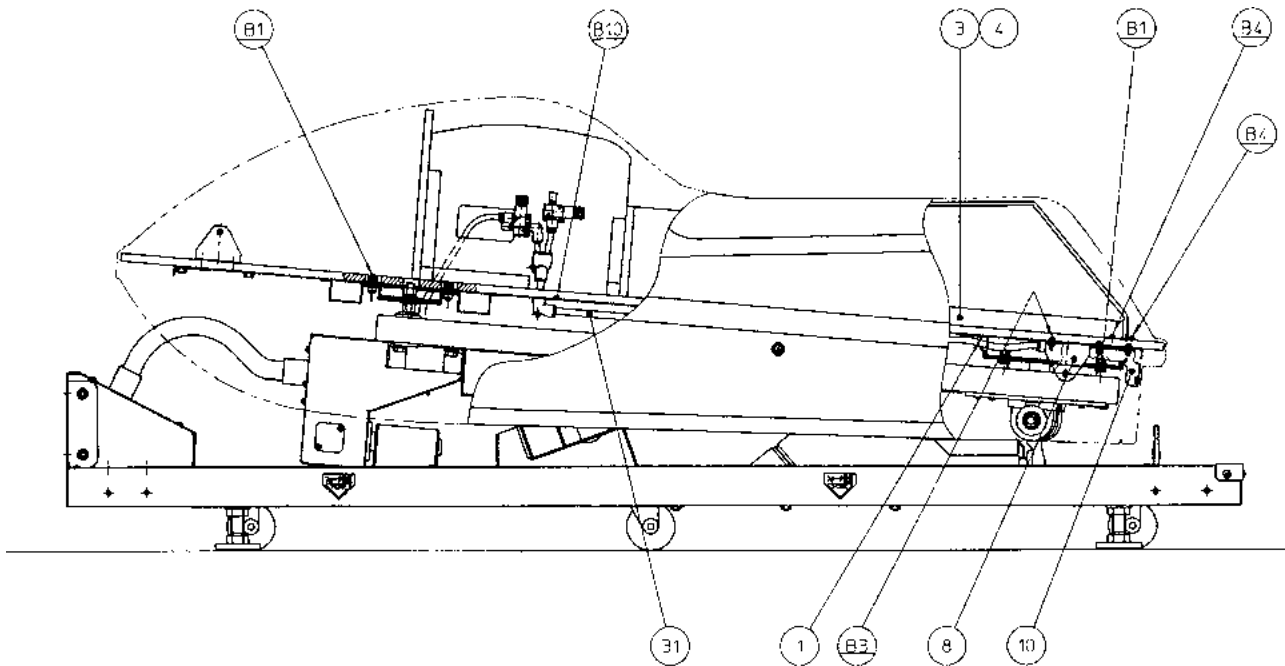

ITEM	DESCRIPTION	PART No
1	RIDE STAND-ON METAL BASE	46000117
3	SIDE VAC-FORM SUPPORT BRACKET - LHS	46000118
4	SIDE VAC-FORM SUPPORT BRACKET - RHS	46000119
8	SIDE VAC-FORM MOUNTING BRACKET	46000122
10	REAR VAC-FORM CLOSING BRACKET	46000124
31	TUBE TU1065-B	46000151
B1	M8x20 HEX HEAD SET SCREW - BZP	88300700
	M8 SPRING WASHER - BZP	28000176
	M8 FLAT WASHER - BZP	28000175
B3	M5x16 PZ PAN HEAD - BZP	26300580
	M5 SPRING WASHER - BZP	28000144
	M5 FLAT WASHER - BZP	28000145
B4	M5x25 PZ PAN HEAD - BZP	26300049
	M5 SPRING WASHER - BZP	28000144
	M5 FLAT WASHER - BZP	28000145
B10	M4x10 PZ PAN HEAD - BZP	26300366
	M4 SPRING WASHER - BZP	28000035
	M4 FLAT WASHER - BZP	28000036

Ride Vac-Forms and Decals

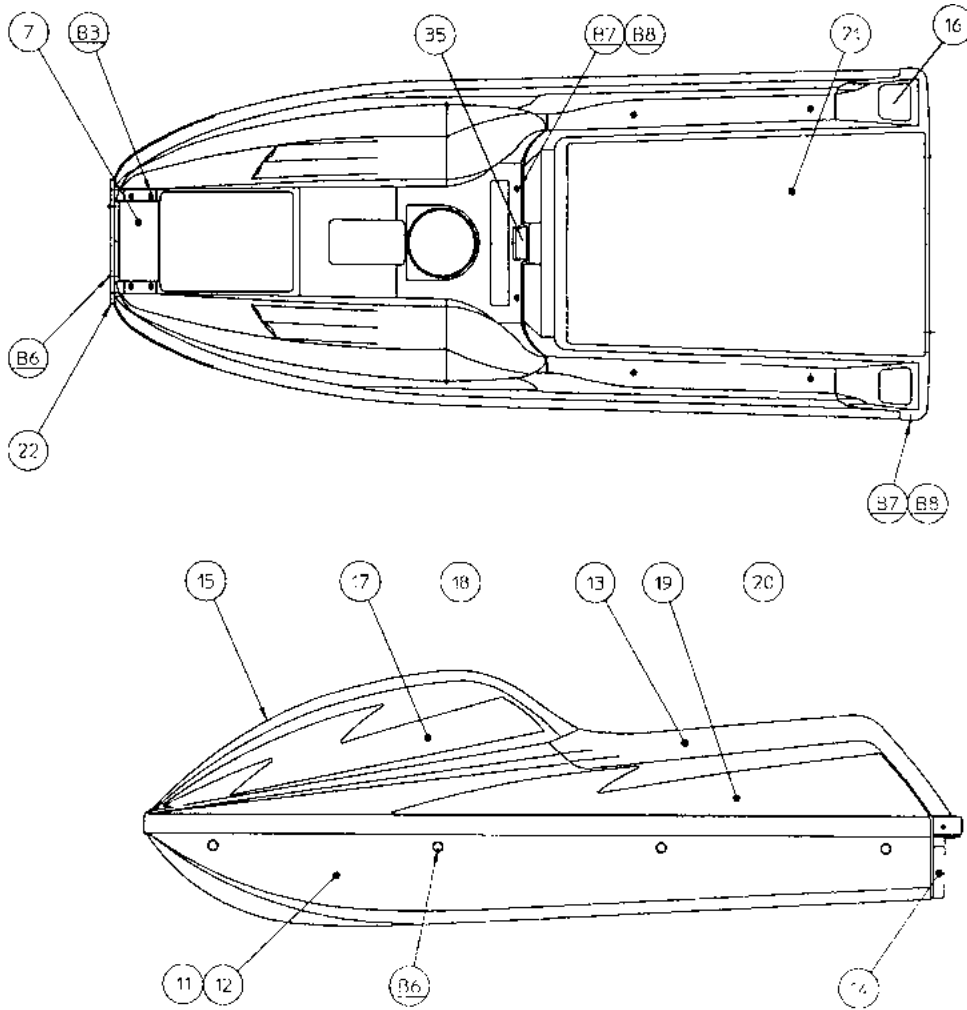

ITEM	DESCRIPTION	PART No
7	FRONT VAC-FORM MOUNTING BRACKET	46000121
11	LOWER VAC-FORM - RHS	46000049
12	LOWER VAC-FORM - LHS	46000048
13	UPPER STANDING AREA VAC-FORM	46000050
14	REAR VAC-FORM	46000051
15	TOP FRONT VAC-FORM	46000052
16	REAR EXHAUST DECAL	40000384
17	SIDE FLASH DECAL - LHS UPPER	40000385
18	SIDE FLASH DECAL - RHS UPPER	40000386
19	SIDE FLASH DECAL - LHS LOWER	40000387
20	SIDE FLASH DECAL - RHS LOWER	40000388
21	3M ANTI SLIP FLOOR MAT - STANDING AREA	46000070
22	FRONT VAC-FORM CLOSING BRACKET	46000125
35	SUPERVISION WARNING DECAL	40000396
B6	M5x16 SECURITY BUTTON HEAD - SUS	26300032
	M5 FLAT WASHER- SUS	28000015
B7	M5x25 SECURITY BUTTON HEAD - SUS	26300033
B8	M5x14 RAWLNUT	27000153

Ride Base Assy

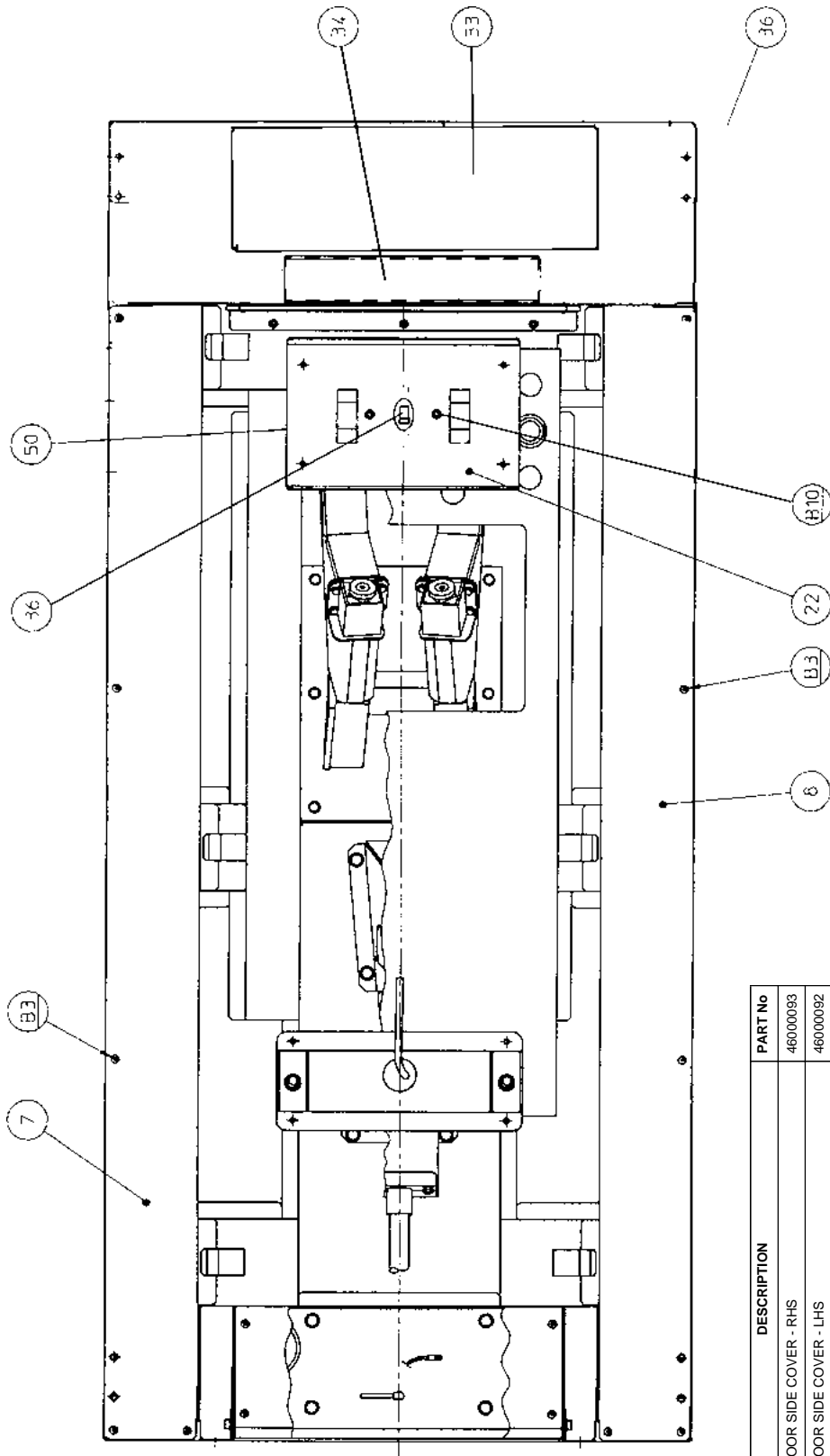

ITEM	DESCRIPTION	PART No
7	MAIN FLOOR SIDE COVER - RHS	46000093
8	MAIN FLOOR SIDE COVER - LHS	46000092
22	AIR SPRING MOUNTING BRACKET - UPPER	46000017
33	3M ANTI SLIP FLOOR MAT - REAR BASE	46000071
34	BASE WARNING DECAL	40000394
36	CONNECTOR KOL-10-U02	46000161
B3	M5x16 SECURITY BUTTON HEAD - SUS	26300032
B10	3/8"x3/4" HEX HEAD SET SCREW - BZP	26500901
	PARTS NOT SHOWN	
	RUBBER SKIRT - LHS	46000168
	RUBBER SKIRT - RHS	46000169
	RUBBER SKIRT FIXING PLATE - BASE	46000170
	RUBBER SKIRT FIXING PLATE - RIDE	46000171

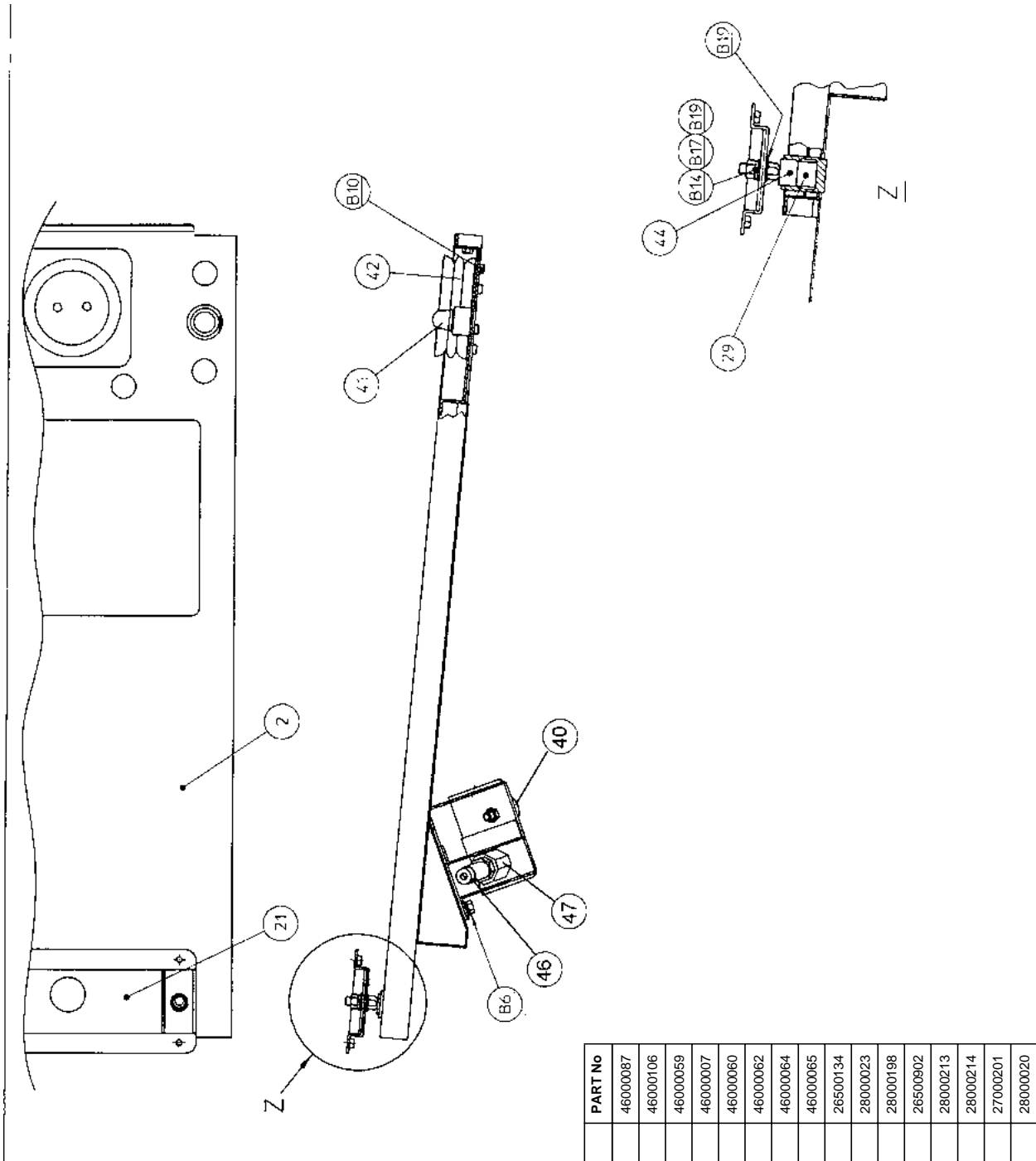

ITEM	DESCRIPTION	PART No
2	RIDE BASE	46000087
21	STEERING ARM MOUNTING BRACKET	46000106
40	RUBBER STOPPER - RI/65/HD	46000059
41	RUBBER STOPPER - RI-30	46000007
42	AIR SPRING	46000060
44	LINK BALL - TBS12	46000062
46	SHOCK ABSORBER - FK/2530/S/NI/M1	46000064
47	SIDE LOAD ADAPTOR - KG/001/NI/M	46000065
B6	M10x25 HEX HEAD SET SCREW - BZP	26500134
	M10 SPRING WASHER - BZP	28000023
	M10 FLAT WASHER - BZP	28000198
	3/8" x 1 3/16" HEX HEAD SET SCREW - BZP	26500602
B10	3/8" SPRING WASHER - BZP	28000213
	3/8" FLAT WASHER - HEAVY DUTY - BZP	28000214
B14	M12 NYLOC NUT - BZP	27000201
	M12 FLAT WASHER - BZP	28000020

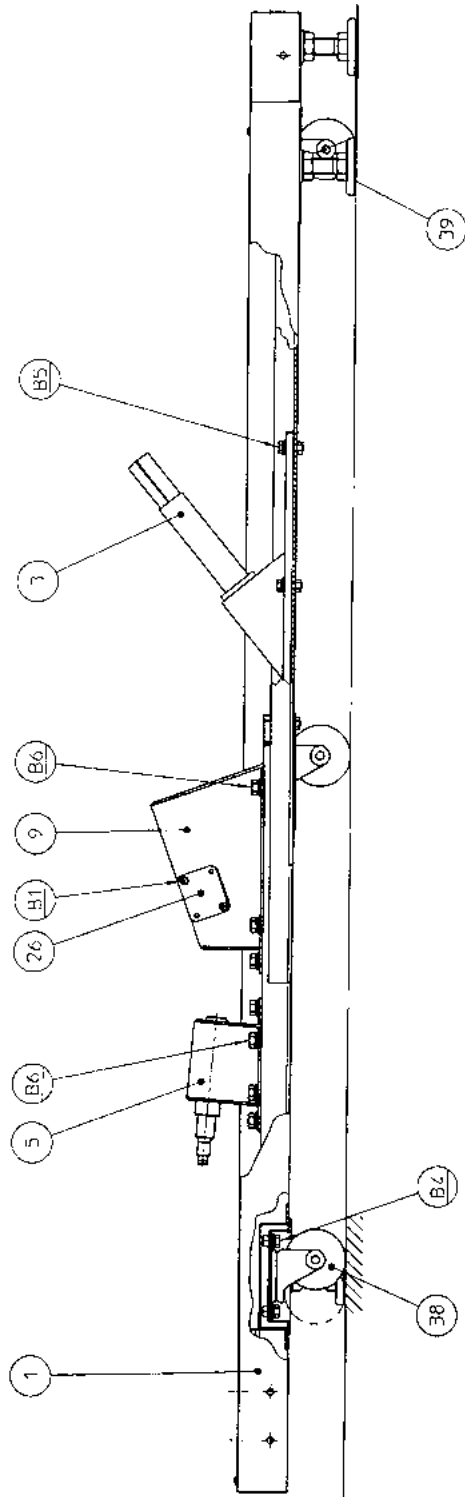

ITEM	DESCRIPTION	PART No
1	MAIN FLOOR BASE	46000086
3	ROSTA SPRING SHAFT MOUNTING ASSY	46000088
5	YAW DRIVE SHAFT	46000090
9	YAW MECHANICAL STOPPER MNTG BRACKET	46000094
26	HARDENED BLOCK	46000108
38	SWIVEL CASTOR 75mm	59000005
39	ADJUSTABLE FOOT M20x70	46000160
	M4x12 PZ PAN HEAD - BZP	26300036
B1	M4 SPRING WASHER - BZP	28000035
	M4 FLAT WASHER - BZP	28000036
	M6x16 HEX HEAD SET SCREW - BZP	26500311
B4	M6 SPRING WASHER - BZP	28000028
	M6 FLAT WASHER - BZP	28000037
	M8x30 HEX HEAD SET SCREW - BZP	26500407
B5	M8 SPRING WASHER - BZP	28000176
	M8 FLAT WASHER - BZP	28000175
	M10x25 HEX HEAD SET SCREW - BZP	26500134
B6	M10 SPRING WASHER - BZP	28000023
	M10 FLAT WASHER - BZP	28000198
	ITEMS NOT SHOWN	
	"FORK HERE" DECAL	40000072
	BASE SIDE WARNING DECAL	40000394

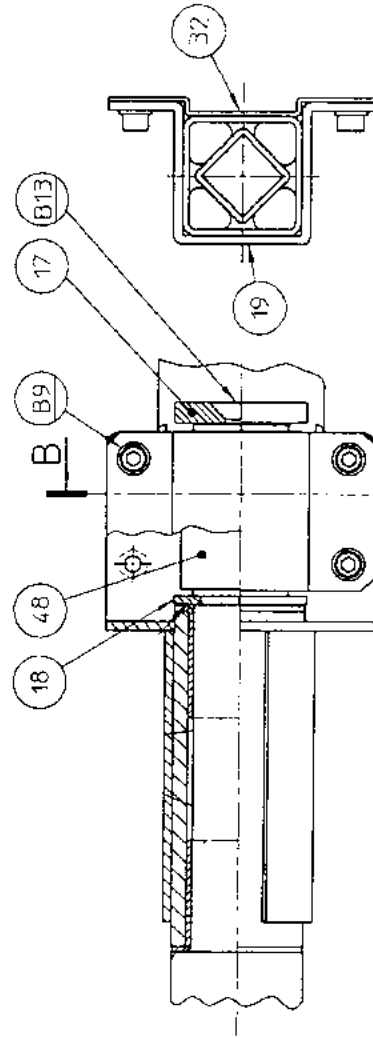
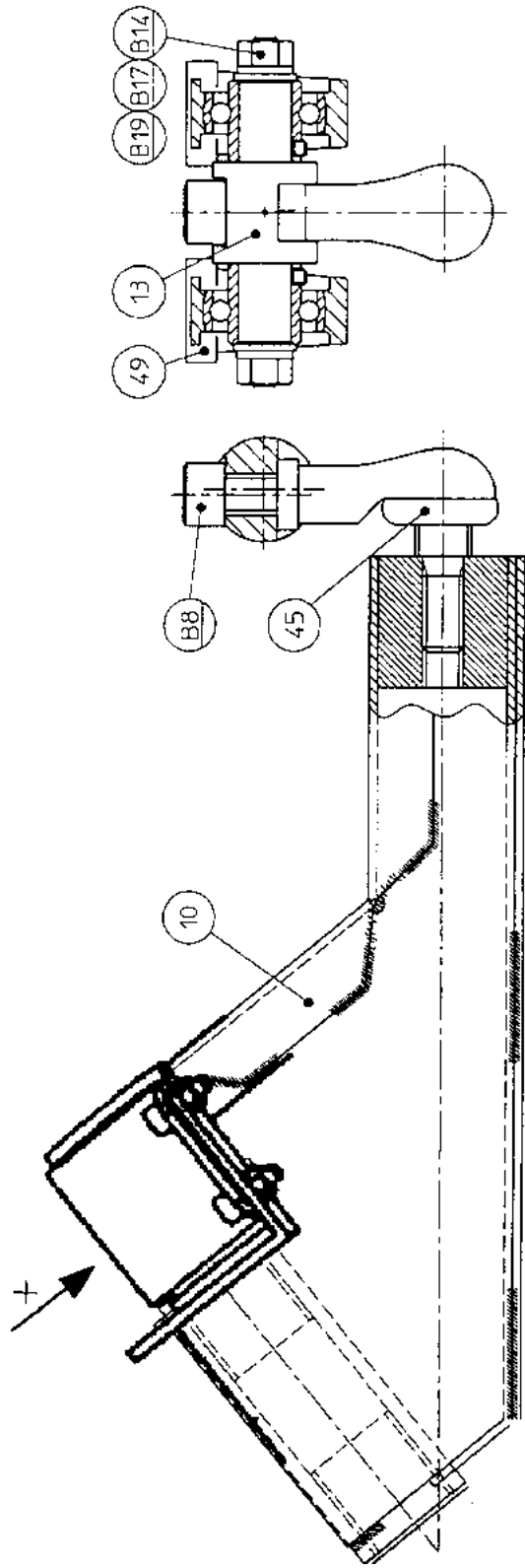

ITEM	DESCRIPTION	PART No
10	ROSTA SPRING MOUNTING SHAFT	46000095
13	LINK BALL MOUNTING SHAFT	46000098
17	ROSTA SPRING RETAINING WASHER	46000102
18	ROSTA SPACER WASHER	46000103
19	ROSTA RETAINING BRACKET	46000104
32	ROSTA SPRING REAR PACKING BRACKET	46000114
45	ROD EYE - RBL16BD	46000063
48	ROSTA SPRING DR-S-27x60	46000067
49	BEARING - UC PA/204/FYH	46000068
B8	M16x40 SOCKET HEAD CAP SCREW - BZP	28500602
B9	M6x16 HEX HEAD SET SCREW - BZP	28500311
B13	M6 SPRING WASHER - BZP	28000028
B14	M6 FLAT WASHER - BZP	28000037
B17	M12x25 CSK CAP SCREW - BZP	26300940
B19	M12 FULL NUT - BZP	27000022
	M12 SPRING WASHER - BZP	28000019
	M12 FLAT WASHER - BZP	28000020

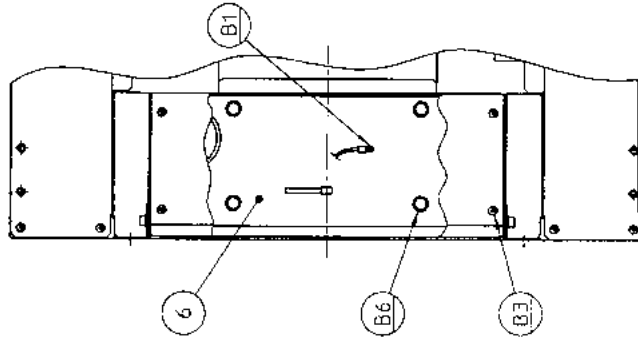
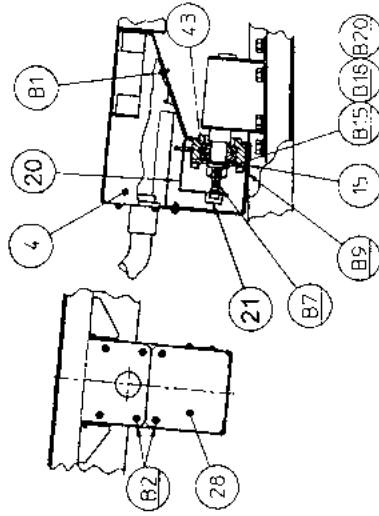
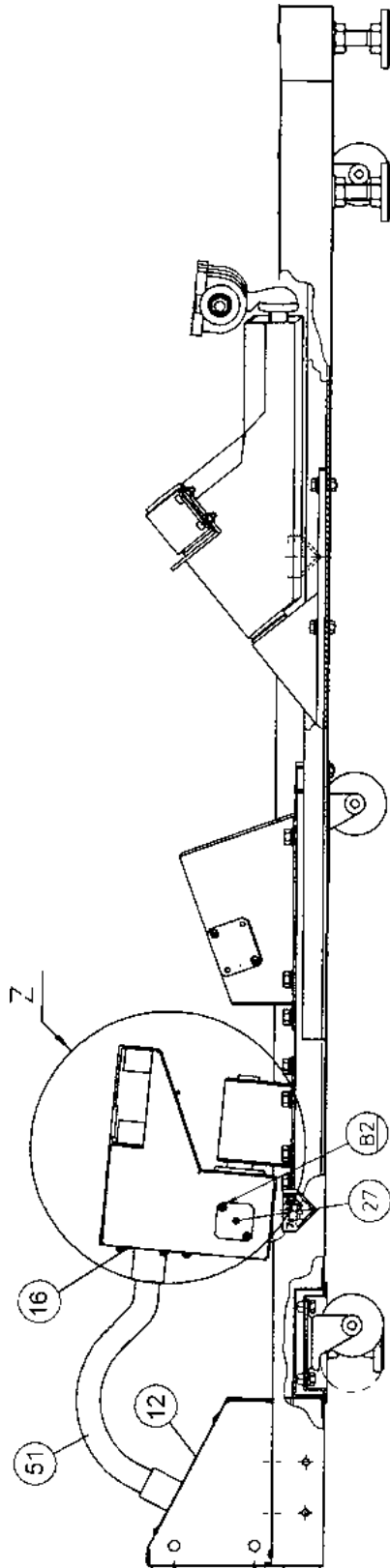

ITEM	DESCRIPTION	PART No
4	DISTRIBUTION BOX	46000089
6	MAIN FRONT JOINT BOX	46000091
12	MAIN FRONT JOINT BOX COVER	46000097
15	BEARING END SPACER	46000100
16	RIDE ASSEMBLY JOINT TUBE MOUNTING BRACKET	46000101
20	YAW POTENTIOMETER MOUNTING BRACKET	46000105
21	YAW POTENTIOMETER	X008-021
27	YAW POT ACCESS PLATE	46000109
28	YAW POTENTIOMETER CLOSING BRACKET	46000110
43	SPHERICAL BEARING - PB 22	46000061
51	TUBE - TUQ805B	46000155
B1	M4x10 PZ PAN HEAD - BZP	26300366
	M4 SPRING WASHER - BZP	28000035
	M4 FLAT WASHER - BZP	28000036
B2	M5x16 PZ PAN HEAD - BZP	26300580
	M5 SPRING WASHER - BZP	28000032
	M5 FLAT WASHER - BZP	28000145
B3	M5x16 SECURITY BUTTON HEAD - BZP	26300032
	M10x25 HEX HEAD SET SCREW - BZP	26500134
B6	M10 SPRING WASHER - BZP	28000023
	M10 FLAT WASHER - BZP	28000198
B7	M4x8 HEX SOCKET SET SCREW - BZP	26300083
	M6x16 HEX HEAD SET SCREW - BZP	26500311
B9	M6 SPRING WASHER - BZP	28000028
	M6 FLAT WASHER - BZP	28000037
B15	M16 FULL NUT - BZP	27000205
	M16 SPRING WASHER - BZP	28000301
	M16 FLAT WASHER - BZP	28000240

10.SCHEMATICS

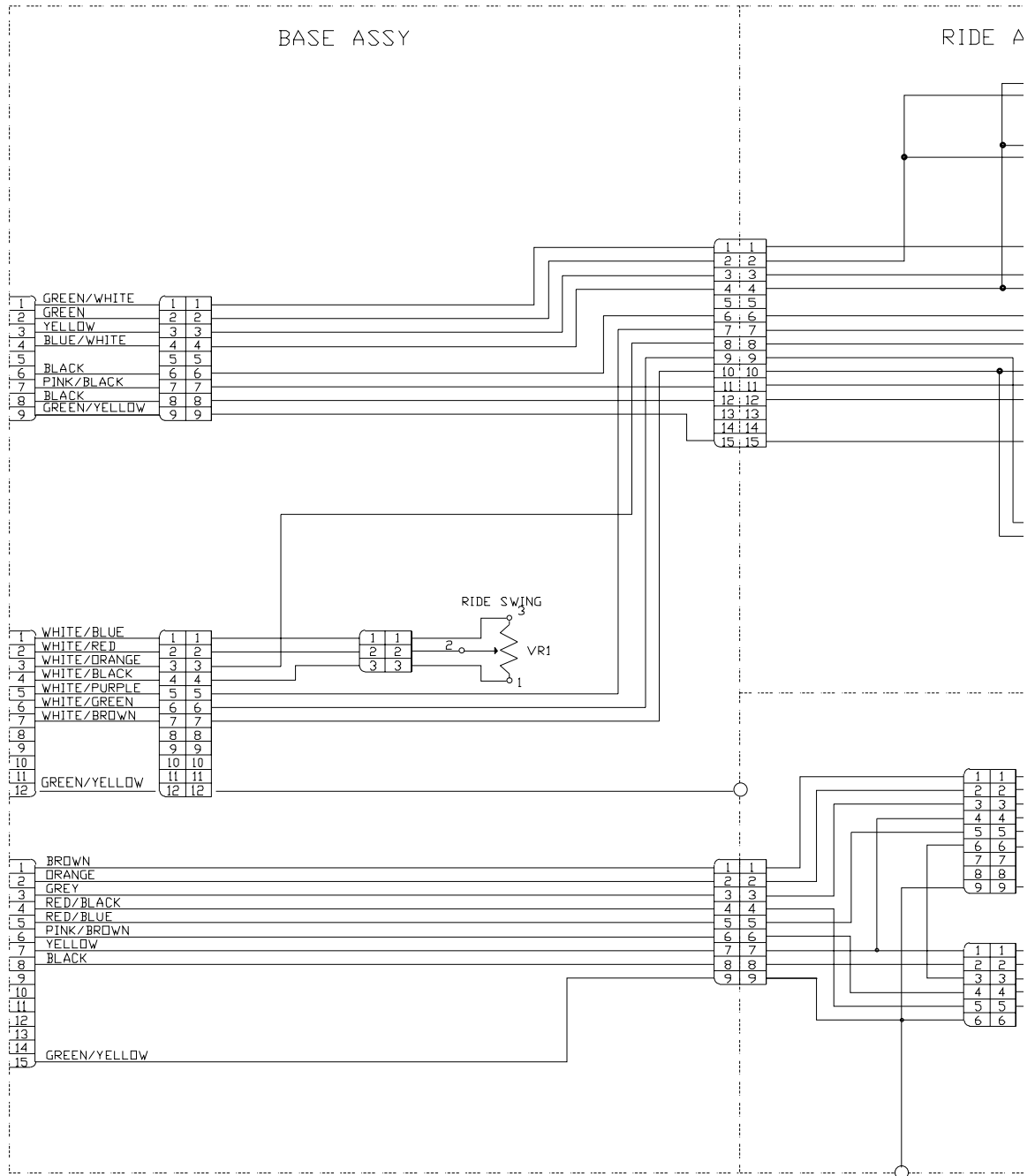

IDE ASSY

CONTROL ARM ASSY

