

namco®

MOTOCROSS GO!™

Instructions for replacing the
Steering Drive Gears and Drive Belt

Removing the Handle Bar Assembly

1. Remove 5 off Security screws (M5x12) and remove the Steering Cover Vac-Form.

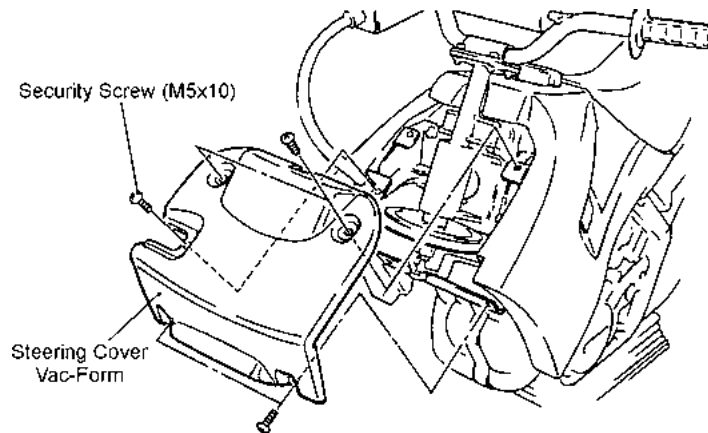

2. Disconnect the handlebar connector.
3. Remove 2 off Pozi head screw (M5x10) and remove the Cable Joint Plate.
4. Remove the Pozi head screw (M4x12) to disconnect the Earth Tag.
5. Remove 8 off Socket cap screws (M8x20) and remove the left and right support brackets.
6. Lift the Handle Bar assembly from the bike moulding only sufficient to disconnect the motor connector, then remove the Handle Bar assembly.

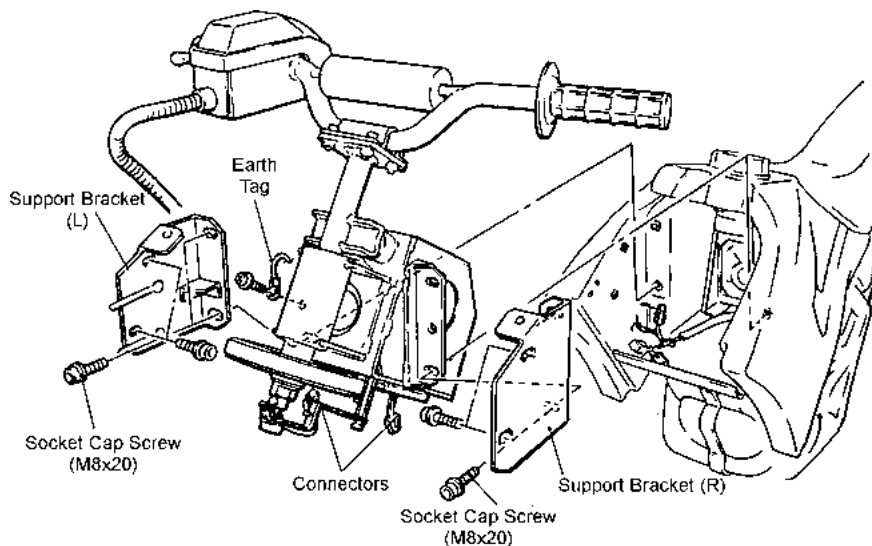

Note : When placing the handle bar assembly on to a surface, ensure that no weight is placed on the Potentiometer.

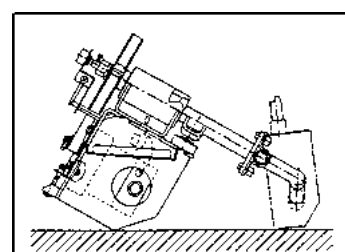

Replacing the Gears and Drive Belt

1. Disconnect the potentiometer connector.
2. Remove the grub screw (M4x10) and remove the potentiometer, complete with bracket. *(Take care not to loose the grub screw which is required to refit the potentiometer.)*
3. Slacken the 4 off Hex head screws (M6x16), securing the motor mounting plate.

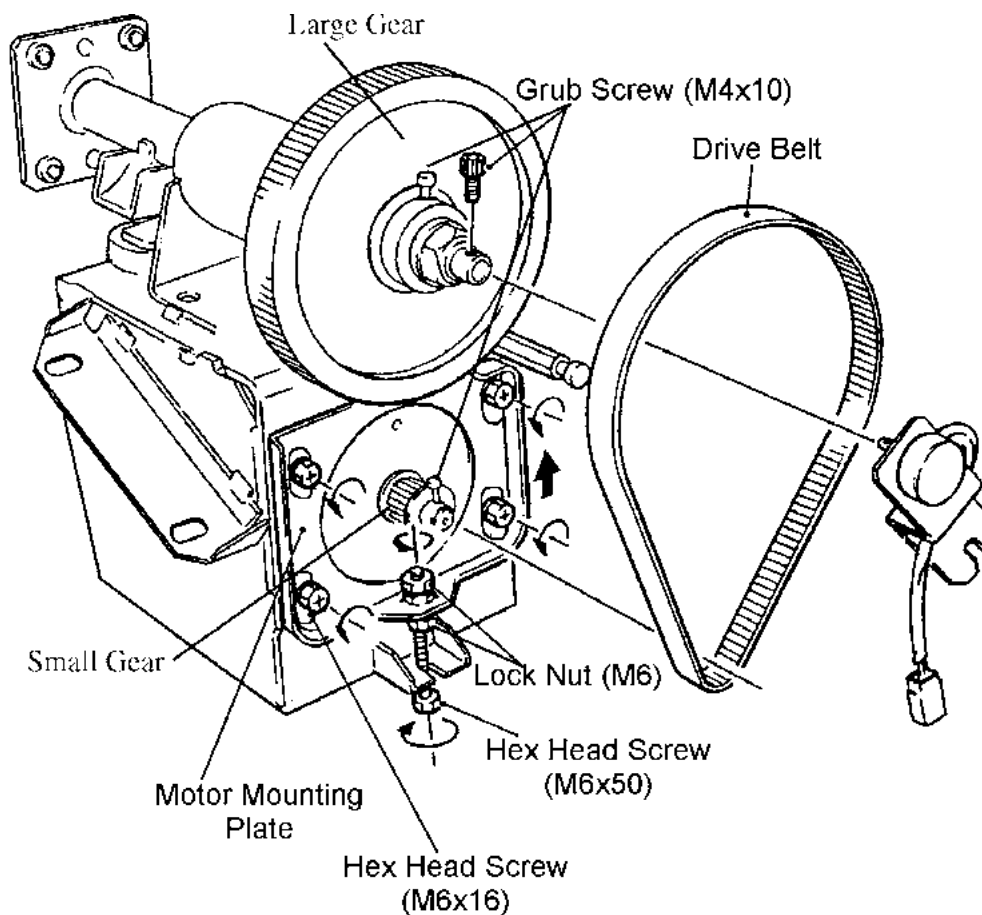

4. Slacken the Lock Nuts (M6) and Adjustment Screw (M6x50), to remove the tension from the Drive Belt, and remove the Drive Belt.
5. Loosen the grub screw (M4x10) on the Large Gear.
6. Remove the nut (M12), flat and spring washers and remove the Large Gear.
7. Fit the new Large Gear and refit the nut (M12), flat and spring washers and tighten the three grub screws (M4x10).
8. Loosen the grub screw (M4x10) on the Small Gear and remove the gear.

9. Fit the spacer (supplied) to the motor shaft, and fit the new Small Gear.
Note: When fitting the small gear ensure that one of the two retaining grub screws engage on the flat of the motor shaft.)
10. Refit the new Drive Belt.
11. Adjust the tension of the new drive belt with the adjuster screw (M6x50). When the tension is correct, re-tighten the two lock nuts (M6)

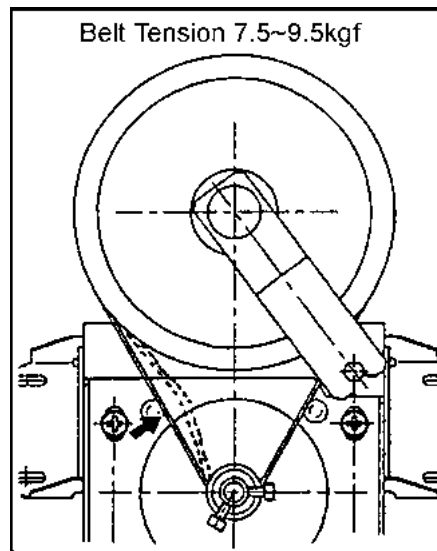

Note:

When refitting the Drive Belt adjust the Adjuster screw (M6x50) to obtain a belt tension of 7.5~9.5kgf. When tensioned correctly a 0.5kgf, applied to the belt as shown, will allow 1.0~1.5mm movement of the belt and a 1kgf applied will allow 2.0~2.5mm of movement. Tighten the Lock Nut (M6) to prevent the adjuster screw from moving.

12. Tighten the 4 Hex Head screws (M6x16).
13. Refit the potentiometer and re-connect the connector.
When replacing the potentiometer ensure that the grub screw engages on the flat of the potentiometer shaft.

Re-Fitting the Handle Bar Assembly

1. Lift the handle bar assembly back into the bike moulding and connect the motor connector.
2. Refit the left and right support brackets with the 8off Socket cap screws (M8x20).
3. Refit the earth tag with the Pozi head screw (M4x12).
4. Refit the Cable Joint Plate with the 2off Pzi head screws (M5x10).
5. Re-connect the connector.
5. Refit the Steering Cover vac-form with the Security screws (M5x12).

RE-INITIALIZE THE BIKE BEFORE NORMAL GAME PLAY

Dispose of the old Gears and Drive Belt after completion

Initialization

Adjustments when Replacing Parts

1. Ensure that the Bike and Handlebar assemblies are in their central stand-by positions.
2. Slide the Test switch "ON" and select 'BIKE INITIALIZATION' from the menu screen (See 6-3 page17). The following screen will be displayed.

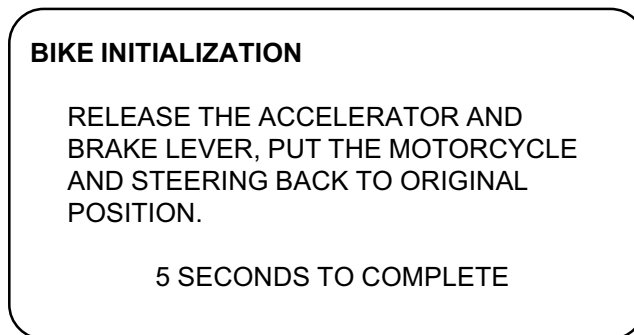

3. After the five seconds the initialization is complete and the following screen will be displayed.

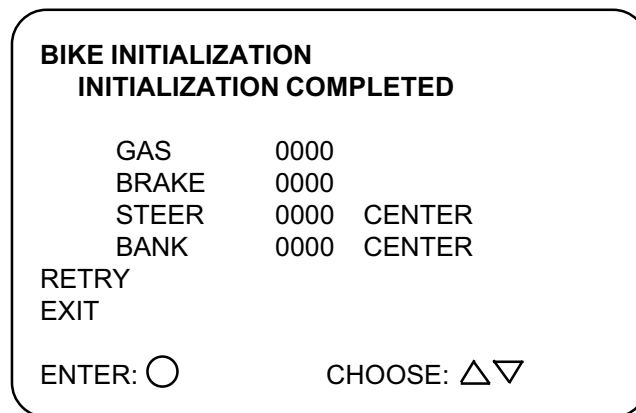

4. When the value of 'GAS', 'BRAKE', 'STEER', and 'BANK' is around '0000', and 'OK' is displayed when each item is operated, the adjustment is completed. Otherwise, select 'RETRY' to readjust the unit.
5. Slide the test switch off to return to normal game mode.

NEW PART NUMBERS

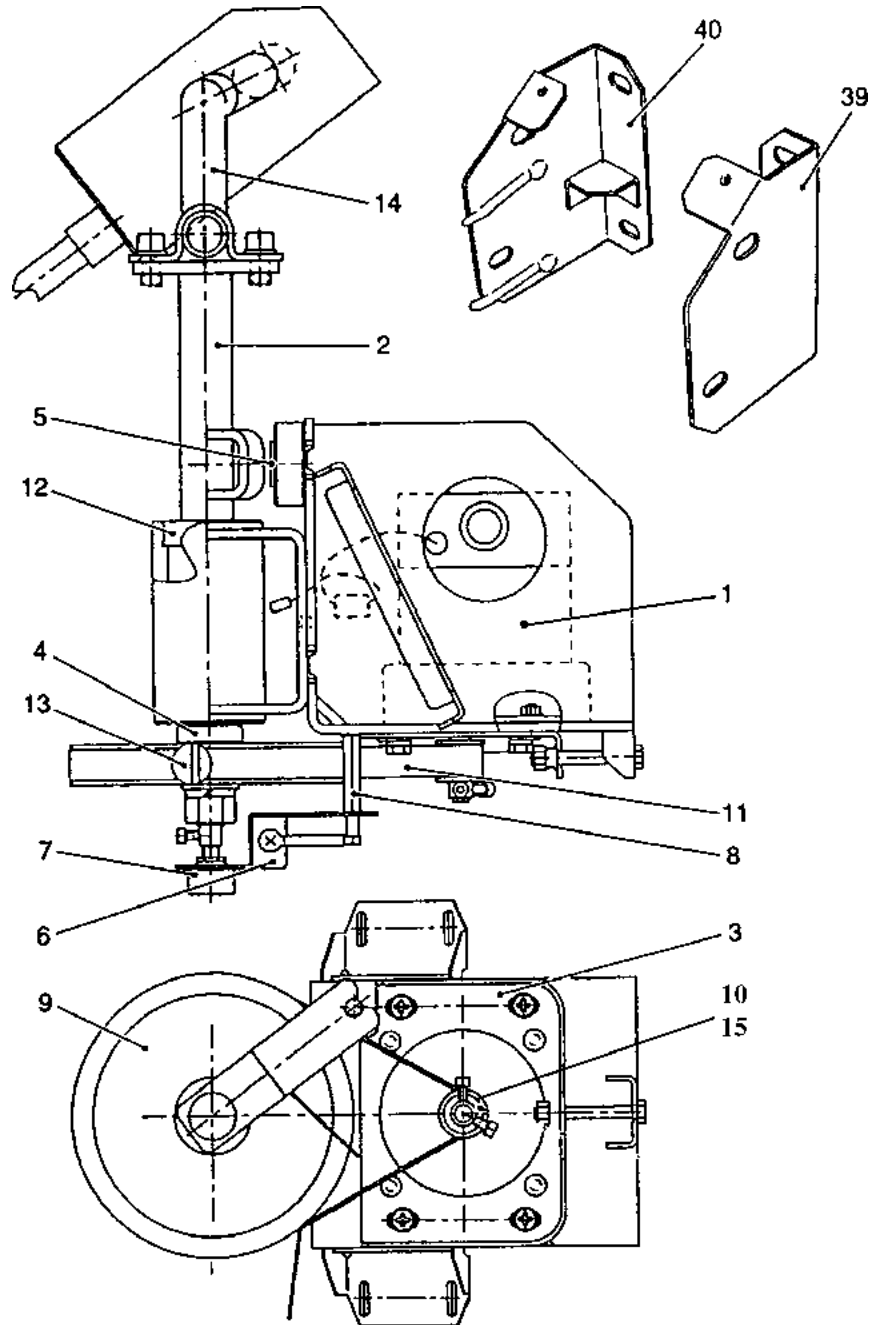

Item	Description	Part No
9	Large Pulley 145T S3M	46000750
10	Spur Gear 36T 3MS	46000751
11	Pulley Drive Belt 537 X 15 S3M	46000749
15	Pulley Spacer	46000752