

namco[®]

POINT BLANK[™]

Operators Manual

© 1994 **namco** Ltd - all rights reserved.

No part of this publication may be reproduced by any mechanical, photographic or electronic process, or in the form of phonographic recording, nor may it be stored in a retrieval system, transmitted or otherwise copied for public or private use, without permission from **namco** Ltd.

While the information contained in this manual is given in good faith and was accurate at the time of publication, BRENT LEISURE LIMITED reserve the right to make changes and alterations without notice.

No responsibility is accepted for unauthorised changes or modifications made to the machine.

Published by:
BRENT LEISURE Ltd.
Unit 1 Brent Crescent,
London. NW10 0QT

Phone:- 0181-965-0550
Fax:- 0181-961-0574

Contents

Operators Manual	1
1. SPECIFICATIONS	4
2. PRECAUTIONS	5
2-1 Cautions When Installing.	5
2-2 Caution when Handling.	5
2-3 Cautions when Transporting.	5
3. ADJUSTMENTS	6
3-1 Turning on the Power	6
3-2 Switches for Adjustments	6
3-3 Volume Adjust	6
3-4 Test Mode	7
3-4-1 Switch Test	7
3-4-2 Gun and Lamp Test	7
3-4-3 Game Menu	8
3-4-4 Coin Options	8
3-4-5 Monitor Test	8
3-4-6 Sound Test	9
3-4-7 Gun Sight Set-Up	9
4. PARTS	9
5. SCHEMATIC	12

1. SPECIFICATIONS

POWER SUPPLY :- 220/240volts AC

MONITOR :- Hantarex 28" Polo Colour Monitor with auto degauss.

DIMENSIONS :- 780(w) x 900(d) x 2080(h)

WEIGHT :- 165kg.

ACCESSORIES :-

- Keys: (Cash Door) 2
- (Coin Door) 2
- (Back Door) 2

- Hex Tamper-Proof Wrench..... 1

- IEC Mains Lead 1

- Operators Manual 1

2. PRECAUTIONS

2-1 Cautions When Installing.

This game is designed for indoor use only. The game must not be installed outdoors or under the following conditions:-

- a. In areas directly exposed to sunlight, high humidity, direct water contact, dust, high heat or extreme cold.
- b. In locations that would present an obstacle in the case of an emergency, i.e. near fire equipment or emergency exits.
- c. On an unstable surface or subject to floor vibration.

2-2 Caution when Handling.

- a. AC power must always be turned OFF, and the game disconnected, before replacing any parts or connecting/disconnecting connectors.
- b. When unplugging the game from an electrical outlet, always grasp the plug, not the mains lead.
- c. The machine must be earthed with a securely connected earthed plug.
- d. Care must be taken at all times to avoid electric shock when inspecting or adjusting the game.

2-3 Cautions when Transporting.

- a. Do not subject the game to physical shock when transporting or moving it.
- b. Always return the levellers to the UP position before moving the machine.
- c. Take care not to rope any moulded (plastic) parts when transporting.

3. ADJUSTMENTS

3-1 Turning on the Power

After installing the product, turn on the power. The power switch is located above the mains inlet on the rear of the cabinet.

3-2 Switches for Adjustments

Open the front door to find the switches for adjustments.

1. Service Switch

Press this switch to obtain game credits without incrementing the coin counter.

2. Test Switch

Slide this switch to "ON" to enter test mode.

Test mode allows game testing and the changing of game settings.

[\(See "3-4 Test Mode" on page 4\)](#)

3-3 Volume Adjust

There are two volume controls, one each for left and right player. Turn the control to increase or decrease the volumes.

SERVICE BRACKET

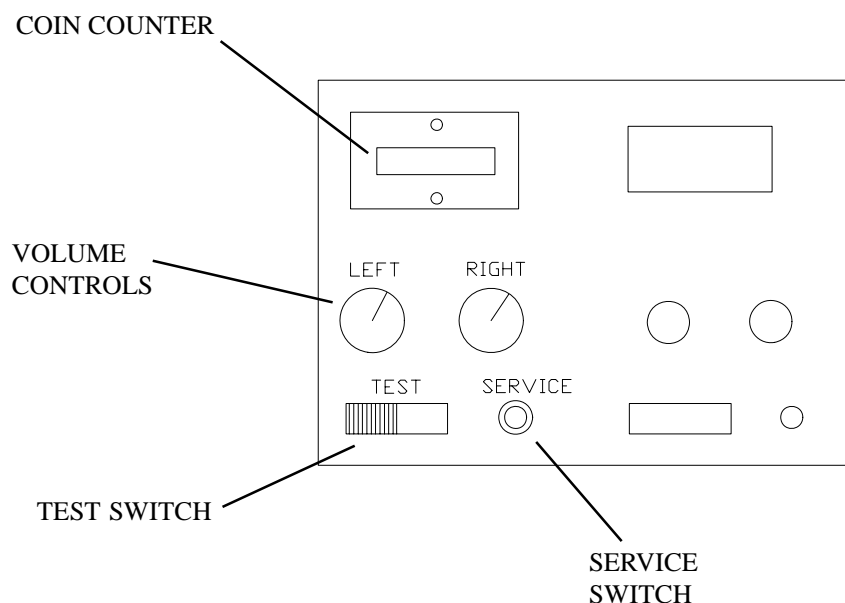

3-4 Test Mode

1. Open the coin door for access to the service bracket, then slide the test switch to "ON". The "Switch Test Screen" appears on the monitor display.
2. Pressing the service button steps through the test screens.
3. When testing is finished ensure that the test switch is returned to the "OFF" position to return to Game Screen

The Test Switch must always be "OFF" during normal game mode.

3-4-1 Switch Test

1. Enter test by switching the Test Switch ON. The "Switch Test Screen" appears.
2. The corresponding writing on the test screen will change to red while the switch under test is activated.

SWITCH TEST		
DIP SW	12	0H
COIN1	COUNT	0H
COIN2	COUNT	0H
1P SWITCH		2P SWITCH
	TRIGGER	TRIGGER
	START	START

3-4-2 Gun and Lamp Test

1. Advance to the GOUT Test Screen from the Switch Test Screen by pressing the service button on the service bracket.
2. Pressing the 1 Player Start Button selects the test required. The selected test will change to red.
3. Pressing the 2 Player Start Button will activate the test.

1P/2P Blowback - Gun recoils each time 2 player start switch is pressed

Auto Blowback - Both guns recoil constantly when 2 player start button is pressed. Pressing start button again turns the test off.

Flash - Not Used

GOUT TEST	
1P	BLOWBACK
	OFF
2P	BLOWBACK
	OFF
1P	START LAMP
	NO
2P	START LAMP
	NO
	FLASH
	NO
	AUTO BLOWBACK
	NO

3-4-3 Game Menu

1. Advance to the Game Menu Screen by pressing the service button.
2. Pressing the 1 Player Start Button selects the test required. The selected test will change to red.
3. Pressing the 2 Player Start Button will change the settings.

GAME MENU	
LIFE	3
MUSIC IN ATTRACT	
YES	
INITIALIZE HI SCORE	
NO	

3-4-4 Coin Options

1. Advance to the Game Menu Screen by pressing the service button.
2. Pressing the 1 Player Start Button selects the test required. The selected test will change to red.
3. Pressing the 2 Player Start Button will change the settings.

Note:- The price of play adjustments are made on the credit board and the coin options must be set as shown in the table.

COIN OPTIONS	
GAME COST	
1 COIN	1 CREDIT
DISCOUNT TO CONTINUE	
NO	
COIN 1 MECH VALUE	
1 COIN COUNT AS 1 COIN	
COIN 2 MECH VALUE	
1 COIN COUNT AS 1 COIN	
BONUS FOR QUANTITY BUY IN	
NONE	
FREE PLAY	
NO	
COIN BOX	
1 WAY	

3-4-5 Monitor Test

1. Advance to the Game Menu Screen by pressing the service button.
2. The monitor will display vertical colour bars.
3. Pressing the service button again will cause the monitor to display a crosshatch pattern.

3-4-6 Sound Test

1. Advance to the Game Menu Screen by pressing the service button.
2. Pressing the 1 Player Start Button changes the request No.
3. Pressing the 1 Player gun trigger will generate a sound. A different sound will be produced each time the request No. is changed.

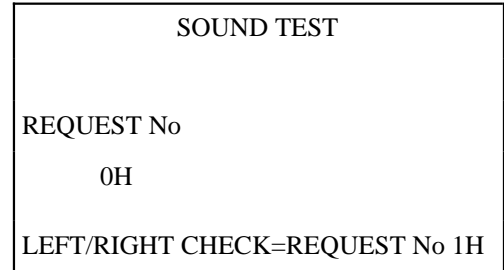

3-4-7 Gun Sight Set-Up

- 1 To initialize gun sight set-up press and hold in the Service Button and slide the Test Switch ON.
- 2 Test screen for player 1 gun will appear. To adjust player 2 gun press the Service Button.
- 3 Follow the instructions on the screen.
- 4 When set-up is completed ensure Test Switch is returned to **OFF**.

4. PARTS

DECALS & PLASTICS

DESCRIPTION	PART No.
Side Decal - LH	40000196
Side Decal - RH	40000197
Front Decal	40000198
Play Panel Overlay	33000022
Top Flash Vac-Form	45000196
Top Flash Acrylic	30000034
Play Instruction Card	42000003

CABINET

DESCRIPTION	PART No.
Front Glass - Toughened (748x580x6)	31000020
Mirror (735x660x3)	31000021
Monitor 28" Hantarex Polo	84000012
Speaker 4½" 20w (with shield can)	62000006
Switch Mode Power Supply	83000040
Schaffner Mains In Assy	66000016
Schaffner Boot	66000017
Fuse 5amp 20mm Slo-Blo	63500600
Interlock Switch	60000006
Interlock Cover	39000028
Transformer	67700015
Bridge Rectifier	71000040
Capicitor 22,000mfd 25v	70200043
Fuse 3amp 1¼" Slo-Blo	63500547
18" 15w Fluorescent Tube	64500000
Choke 15w	63300000
Starter	63000000
75mm Castor	59000005
M16 Adjustable Foot	88300079
100ohm 10w W/W Potentiometer	76000164
3.5-6v Panel Meter	65000002
Service Switch	60000059
Start Button Assy - Red	60200235
Start Button Assy - Blue	60200237
Test Switch	60000023
Gun Assy - Red	XPB-GUNRED
Gun Assy - Blue	XPB-GUNBLUE
Gun Chain	45000209
Chain Clip	45000211
Holster	45000199

5. SCHEMATIC

