

namco[®]



RIDGE RACER

Operators Manual

1993 **namco** Ltd - all rights reserved

No part of this publication may be reproduced by any mechanical, photographic or electronic process, or in the form of phonographic recording, nor may it be stored in a retrieval system, transmitted or otherwise copied for public or private use, without permission from **namco** Ltd.

Published by:
BRENT LEISURE Ltd.
Unit 1 Brent Crescent,
London. NW10 0QT

Phone:- 081-965-0550
Fax:- 081-961-0574

Contents

1

1. SPECIFICATIONS	4
2. PRECAUTIONS	5
2-1 Cautions When Installing.	5
2-2 Caution When Handling.	5
2-3 When Transporting.	5
3. MAJOR COMPONENTS	6
This is already fitted at the factory	7
4. INSTALLATION	7
4-1 Connecting the Main Body Assy and the Base Assy	7
4.2 Adjusting the Level Adjustors	7
4.3 Fixing the Signboard Assy	7
5. SIDE PANELS	8
5-1 Removing the Side Boards (R) and (L)	8
5-2 Removing the Dashboard Covers (R) and (L)	8
6. ADJUSTMENTS	9
6-1 Turning on the Power	9
6-2 Switches for Adjustments	9
6-3 Test Mode	10
6-3-1 Setting the Game Fee and So On (On the Coin Options Screen)	11
6-3-2 Changing the Game Settings (on the Game Options Screen)	12
6-3-3 Switch Test	13
6-3-4 Sound Test (Adjusting the Sound Volume).....	14
6-4 Adjusting the Game After Replacing Parts (Initializing the Game)	15
7. HOW TO PLAY	16
8-1 Removing the Game Printed Circuit Board (PCB)	17
8-2 Removing the Shield Case.....	18
8-3 Removing the Power Control Panel	18
8-4 Signboard Assy	18
8-4-1 Replacing the Fluorescent Lamp	18
8-6 AB Pedal Assy (Replacing the Control)	19
8-7 Clutch Pedal Assy (Replacing the Micro Switch)	20
8-8 Steering Assy	20
8-8-1 Replacing the control	20
8-8-2 Replacing The Steering Wheel	20
8-9 Gear Shift Assy (removing).....	21
8-10 Replacing the Speaker	21
8-11 Replacing the Monitor	22
9. PARTS LIST	23

1. SPECIFICATIONS

POWER SUPPLY: 220 / 240 Volts AC

MONITOR: Hantarex 33" Polo Colour Monitor with auto degause

DIMENSIONS:

When Assembled: 1210 (w) x 2015 (d) x 2000 (h)
When Divided: Body 1210 (w) x 1190 (d) x 2000 (h)
Base 810 (w) x 1250 (d) x 1240 (h)

WEIGHT:

When Installed: 358kg
When Divided: Body 258kg
Base 100kg

ACCESSORIES

Keys: (Cash Door) 2
(Coin Door) 2
(Back Door) 2
Instruction Manual 1

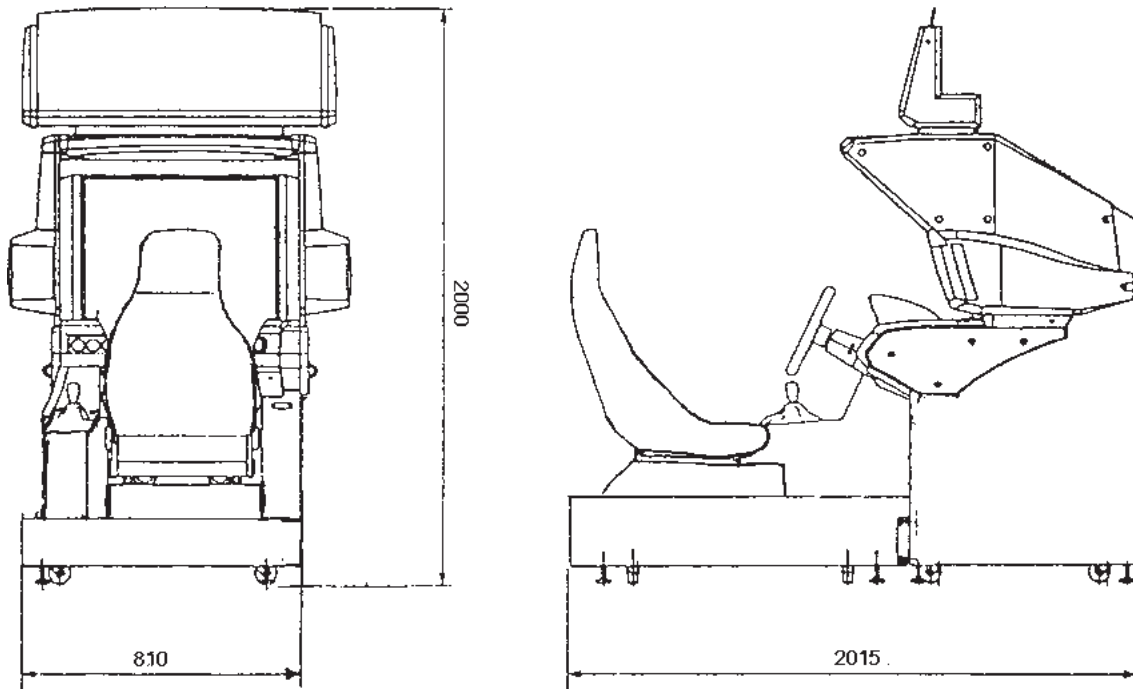

2. PRECAUTIONS

2-1 Cautions When Installing.

This game is designed for indoor use only. The game must not be installed outdoors or under the following conditions:

- a. In areas directly exposed to sunlight, high humidity, direct water contact, dust, high heat or extreme cold.
- b. In locations that would present an obstacle in case of emergency, i.e. near fire equipment or emergency exits.
- c. On an unstable surface or subject to floor vibration.

2-2 Caution When Handling.

- a. AC power must always be turned OFF, and the game disconnected , before replacing any parts or connecting/disconnecting connectors.
- b. When unplugging the game from an electrical outlet, always grasp the plug, not the mains lead.
- c. The machine must be earthed with a securely connected earthed plug.
- d. Care must be taken at all times to avoid electrical shock when inspecting or adjusting the game, especially around the monitor.
- e. Adjustment is required whenever the game PCB board, ROM, steering Assy, AB pedal Assy or control are replaced. See "[6-4 Adjusting the Game After Replacing Parts](#)" on page 15.

2-3 When Transporting.

- a. Do not subject the game to physical shock when transporting or moving it.
- b. Always return the levellers to the extreme UP position before moving the machine.
- c. Take care not to rope any moulded (plastic) parts when transporting.
- d. Always split machine into two parts before moving or transporting.

3. MAJOR COMPONENTS

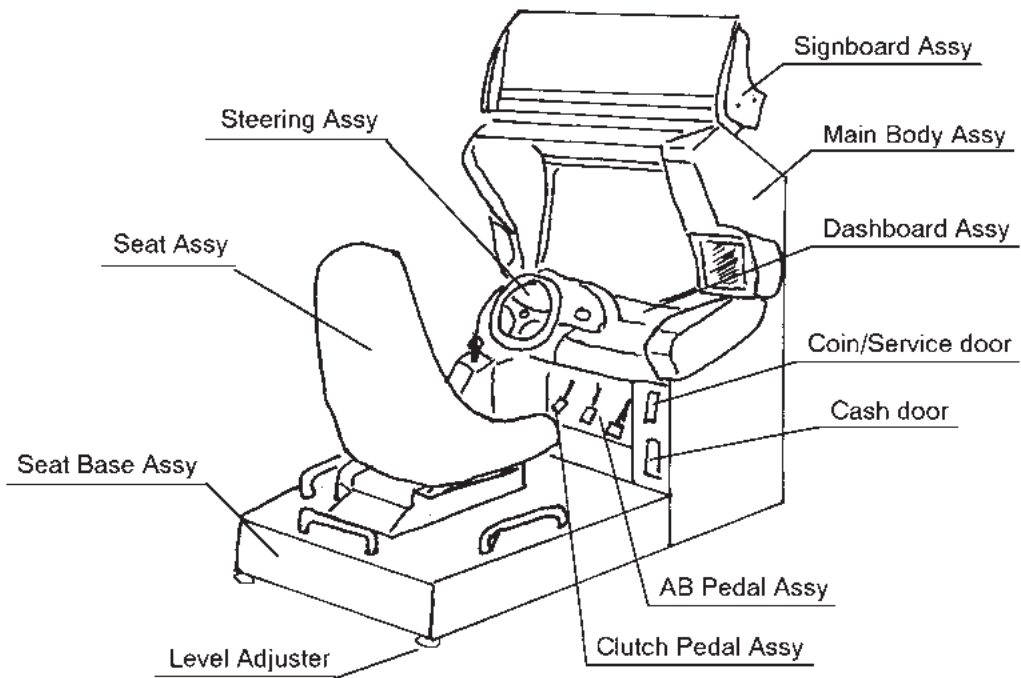
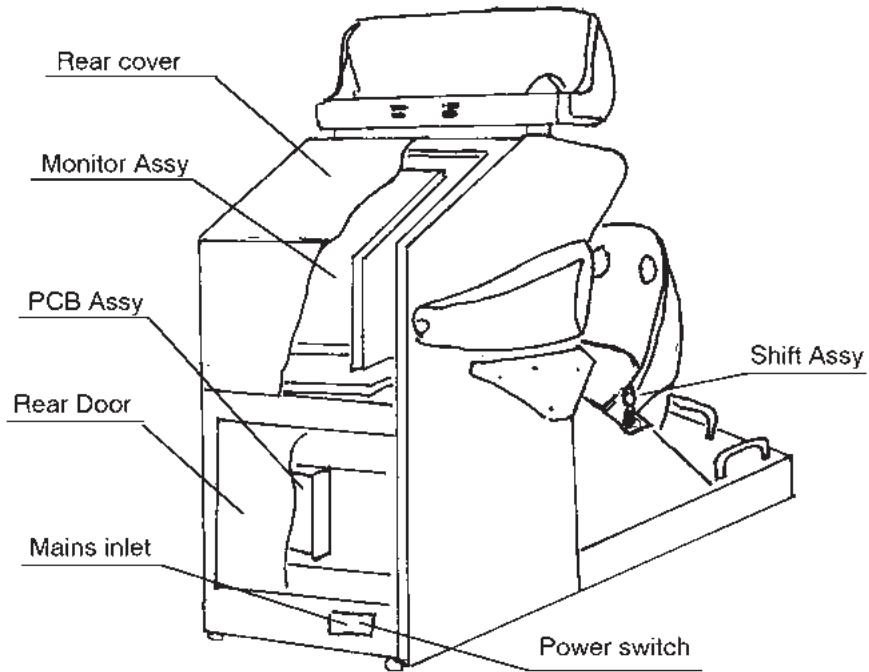

4. INSTALLATION

Locate the two connection plates, 16 (M10x30) hex head bolts, 16 M10 spring washers and 16 M10 flat washers.

4-1 Connecting the Main Body Assy and the Base Assy

1. Place the main body Assy and the base Assy in the installation site.
2. Connect the connectors of the main body Assy to that of the base Assy.
3. Fix the main body Assy to the base Assy with two connection plates and sixteen hexagonal bolts (M10 x 30), spring washers and flat washers.

4.2 Adjusting the Level Adjustors

Adjust the level adjustors of the main body Assy and those of the base Assy (four each for the main body Assy and the base Assy) with a wrench (24mm) so that the casters are lifted from the floor surface by about 5mm. Then install the product stably and back up the lock nut to lock the adjuster.

4.3 Fixing the Signboard Assy

This is already fitted at the factory

The signboard Assy is heavy and it is recommended two or more persons perform the following operations.

1. Connect the connector of the main body Assy and that of the signboard Assy. Insert the bottom of the signboard Assy along two protrusion of the main body Assy.
2. Fix the signboard Assy to the main body Assy with two flange sockets (M6 x 12)

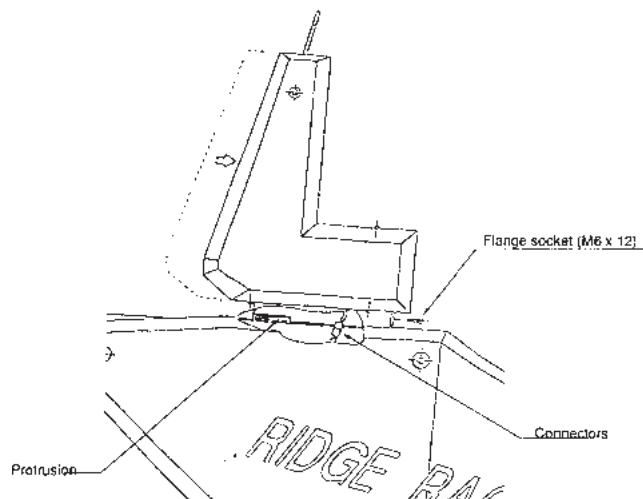

5. SIDE PANELS

5-1 Removing the Side Boards (R) and (L)

1. Remove eight torque bolts (M5 x 12), then the monitor panels (R) and (L).
2. Disconnect the connector and remove six hexagonal bolts (M6 X 30). Then remove the side boards (R) and (L).

5-2 Removing the Dashboard Covers (R) and (L)

Remove five torque bolts (M5 X 12), then the dashboard covers (R) and (L).

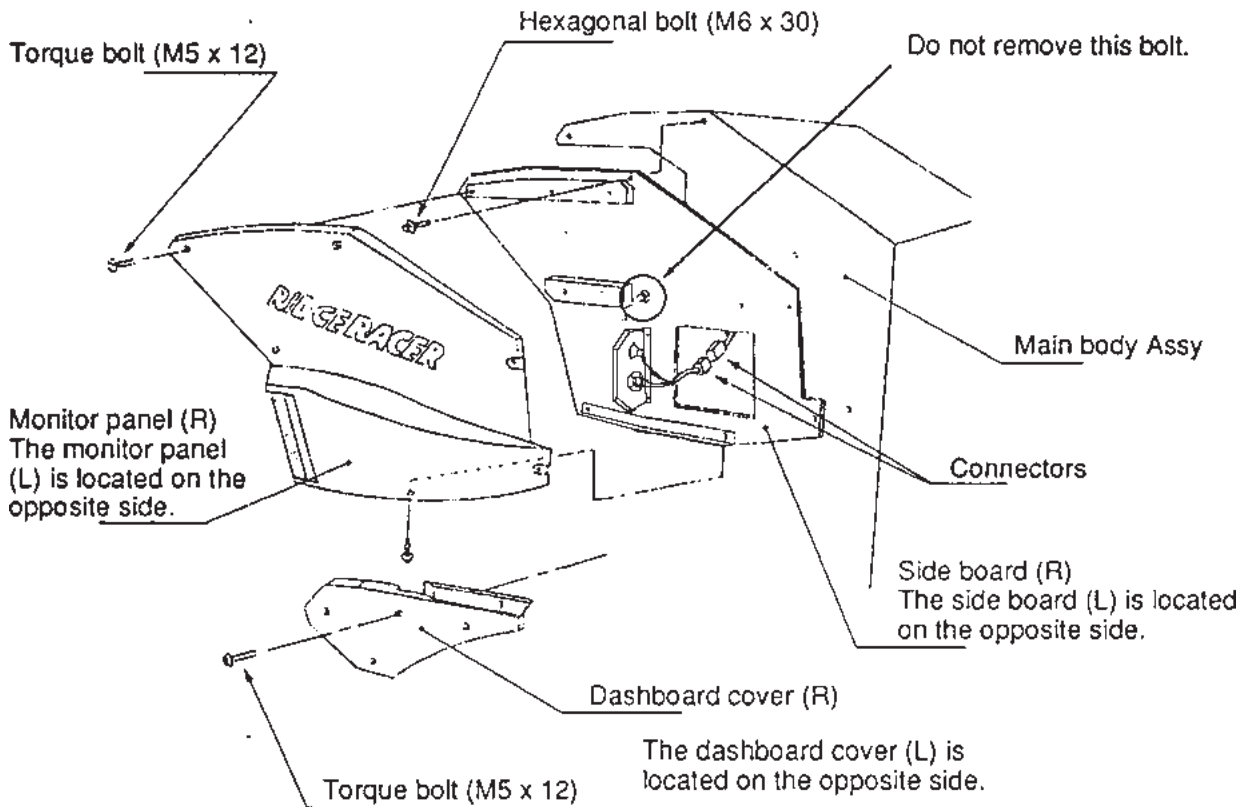

6. ADJUSTMENTS

6-1 Turning on the Power

After installing the product, turn on the power. The power switch is located above the mains inlet on the rear of the main body.

6-2 Switches for Adjustments

Open the coin door to find the switches for adjustments.

1. Service switch.

Press this switch to increase the number of credits without incrementing the coin counter.

2. Test switch.

Set this switch to "ON" to enter test mode.

You can change the game fee and so on, and perform various tests in Test mode.
(See "6-3 Test Mode" on page 10).

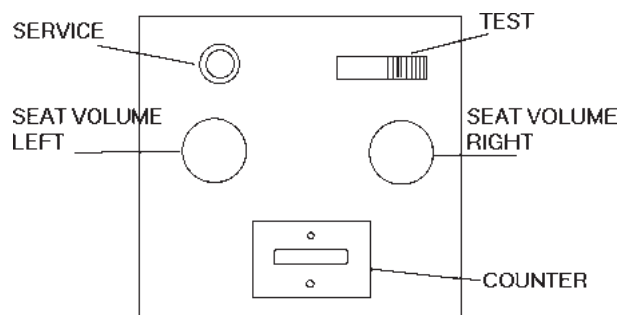

6-3 Test Mode

1. Open the coin door, then set the test switch to “ON”. The “Menu Screen” appears on the monitor display.
2. Select the item to be tested by turning the steering wheel right or left. The colour of the item you selected changes.
3. Step on the accelerator pedal to display the menu of the selected item. To return to the “Menu Screen”, step on the brake pedal (step on both the brake and clutch pedals on the Switch Test Screen).
4. When the test finishes, set the test switch to “OFF” to return to the Game Screen.

The Test switch must always be “OFF” during normal game mode.

MENU	
COIN OPTIONS _____	(1) For setting the price of play (See 6-3-1)
GAME OPTIONS _____	(2) For setting the game options (See 6-3-2)
BOARD TEST _____	(3) For testing the game PCB
SWITCH TEST _____	(4) For testing switches (See 6-3-3)
SOUND TEST _____	(5) For adjusting the sound volume (See 6-3-4)
MONITOR TEST _____	(6) For monitor adjustments
ADS TEST _____	(7) For displaying the game data collected
ABOUT _____	(8) For restoring each setting to standard value
IN = STEP ON THE GAS	

6-3-1 Setting the Game Fee and So On (On the Coin Options Screen)

Select 1 “COIN OPTIONS” on the Menu Screen to set the game fee and so on.

Turn the steering wheel to select the item to be changed, then step on the accelerator pedal.

Turn the steering wheel again to change the setting, then step on the accelerator pedal (See table 1.)

Step on the brake pedal to return to the Menu Screen.

Note: *The price of play adjustments are made on the credit board and the coin options should be set as the following table.*

COIN OPTIONS	
GAME COST 2 COINS 1 CREDIT	(a)
COIN 1 MECH VALUE 1 COIN COUNT AS 1 COIN	(b)
COIN 2 MECH VALUE 1 COIN COUNT AS 1 COIN	(c)
BONUS FOR QUANTITY BUY-IN NONE	(d)
FREE PLAY OFF	(e)
EXIT = STEP ON THE BRAKE	

Item	Description		
(a) Game fee	Number of credit pulses necessary for game credit	One to nine	Set to 1
(b) Coin 1 mechanism	Number of credit pulses per coin	One to nine	Set to 1
(c) Coin 2 mechanism	Not Used	One to nine	
(d) Bonus	The extra credit given as a bonus when the specified number of coins are inserted	One credit per one coin Three credits per nine coins	Set to NONE
(e) Free play	Free play started by stepping on the accelerator	OFF/ON	set to OFF

6-3-2 Changing the Game Settings (on the Game Options Screen)

Select 2 “GAME OPTIONS” then change the game options.

Turn the steering wheel to select the item to be changed then step on the accelerator pedal.

Turn the steering wheel again to change the setting, then step on the accelerator pedal (see table 2).

Step on the brake pedal to return to the Menu Screen.

GAME OPTIONS (DEFAULT IN GREEN)		
GAME DIFFICULTY	TIME EXTEND	
NOVICE	D ** ** *	(a)
ADVANCED	D ** ** *	(b)
EXPERT	D ** ** ** *	(c)
T. T.	D ** ** ** *	(d)
LAP		
NOVICE	2	(e)
ADVANCED	3	(f)
EXPERT	3	(g)
T. T.	3	(h)
SPEED	KM/H	(i)
SOUND IN ATTRACT	ON	(j)
EXIT = STEP ON THE BRAKE		

Settings of the Game Options Screen

Item	Description	Factory setting
(a) Play time for the novice level	A (shortest) to H (longest)	D
(b) Play time time for the advanced level	A (shortest) to H (longest)	D
(c) Play time for the expert level	A (shortest) to H (longest)	D
(d) Play time for the time trial game	A (shortest) to H (longest)	D
(e) Laps for the novice level	2 to 5	2
(f) Laps for the advanced level	2 to 5	3
(g) Laps for the expert level	2 to 5	3
(h) Laps for the time trial game	2 to 5	3
(i) Unit of speed	KM/H (kilometer) Set for country of use MPH (Mile)	
(j) Attract sound	ON/OFF	ON

6-3-3 Switch Test

Select 3 "SWITCH TEST" to display the following screen.

SWITCH TEST			
DIP SW2	12345678	_____	(a) Option switch (SW2 on the CPU)
	SW3 12345678	_____	(b) Option switch (SW3 on the CPU)
STEERING	*0000	_____	(c) Steering
GAS	*0000	_____	(d) Accelerator
BRAKE	*0000	_____	(e) Brake
CLUTCH	OFF	_____	(f) Clutch
SHIFT	N	SWITCH 1 OFF —	(g) Shift
		SWITCH 2 OFF	
		SWITCH 3 OFF	
		SWITCH 4 OFF	
SERVICE	OFF	_____	(h) Service switch
COIN 1	OFF	_____	(i) Coin 1 switch
COIN 2	OFF	_____	(j) Coin 2 switch
EXIT = STEP ON THE BRAKE AND CLUTCH			

- The status of the option switch SW2 on the game PCB (CPU-PCB) is indicated here.
- The status of the option switch SW3 on the game PCB (CPU-PCB) is indicated here.
The SW2 or SW3 switch is set to ON when the corresponding number is red.
- When you turn the steering wheel to the right, the number increments. When turning it to the left, the number decrements.
- When you step on the accelerator pedal, the number increments.
- When you step on the brake pedal, the number increments. An approximate value of "0000" appears on the item c, d or e respectively when you locate the steering wheel in the middle and when the accelerator and brake pedals are released. (Even if the least digit of the number changes, the game is operating normally). "OK" appears to the right of the number when the accelerator and brake pedals are depressed.
- "ON" appears when you depress the clutch pedal.
- The position of the shift (1 to 6, N) and the status of four switches are indicated here.
When you move the shift lever forwards, the switch 1 is set to ON. When you move it backwards, the switch 2 is set to ON. When you move it to the left direction, the switch 3 is set to "ON". When you move it to the right direction, the switch 4 is set to ON.
- "ON" appears when you press the service switch inside the coin door.
- "ON" appears when you operate the coin 1 switch.
- Not used.

To return to the Menu Screen, step on both the brake pedal

6-3-4 Sound Test (Adjusting the Sound Volume)

Select “SOUND TEST” on the menu screen to adjust the sound volume. The following screen appears.

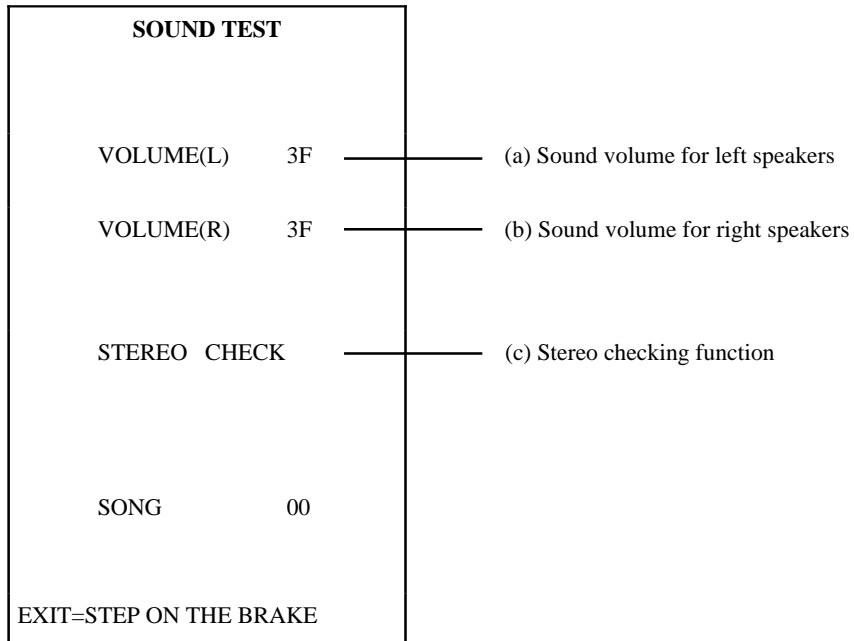

Use the steering wheel to select the item to be changed. Step on the accelerator and the item selected will stop flashing. Use the steering to adjust the level. Step on the accelerator when the desired setting is reached and the item will start flashing. The steering can now select another item.

The sound volume can be adjusted in 64 steps between 00 (minimum) to 3F (maximum). The factory setting is “3F”. (i.e. Loudest)

When you select (c) and step on the accelerator pedal, sound is produced the left speaker, then the right speaker. Step on the brake pedal to return to the Menu Screen.

The volume controls on the service bracket enable the seat volume to be reduced from the main volume.

6-4 Adjusting the Game After Replacing Parts (Initializing the Game)

Be sure to adjust the game with the following the instructions below after replacing any part. Otherwise, the game will not function correctly.

1. Ensure that the accelerator and brake pedals are released and the steering is in the centre.
2. Hold down the service switch and slide to the test switch to “ON”. The following screen appears on the monitor display.

ADJUST	
STEERING	0000
GAS	0000
BRAKE	0000

3. To zero the settings press the service switch.
4. When each number on the right hand side of the items: STEERING, GAS and BRAKE is about “OOOO”, the adjustments are complete.
5. Set the test switch to “OFF” to return to the Game Screen.

The test switch must always be “OFF” during normal game mode.

7. HOW TO PLAY

- This is **the** car race game.
- Players can enjoy virtual driving with a clutch and shift lever (Automatic setting is also selectable).
- Four difficulties are provided: NOVICE, INTERMEDIATE, ADVANCED and TT (Time Trial) and two types of operations can be selected use of clutch and shift lever or automatic.

(Outline of a Game)

- When a player drives a car the specified number laps within the given time, he or she finishes the race, the ranking, lap time and total time are displayed and the game is over.
- If the remaining time becomes “O” before a player finishes the race, the game is over.

(Starting a Game)

- Insert coins, then select the difficulty.
Turn the steering wheel to select the difficulty from NOVICE, INTERMEDIATE, ADVANCED and TT, then step on the accelerator pedal to set it.
- Select the operation type: clutch and shift lever or automatic in the same manner as above.
- If a player does not select the above items within 10 seconds, the game sets its choices by itself.

(Difference of the Difficulty Levels)

- When a player selects the NOVICE level, he or she drives a car on the MAIN COURSE at a low speed. This is the player’s car vs. computer driven cars race game.
- When a player selects the INTERMEDIATE level, he or she drives a car on the MAIN COURSE at a high speed. This is the player’s car vs. computer-driven cars race game.
- When a player selects the ADVANCED level, he or she drives a car on the MAIN COURSE and a TECHNICAL BRANCH at a high speed. This is the player’s car vs. computer-driven cars race game.
- When a player selects the TT level, he or she drives a car on the MAIN COURSE and the TECHNICAL BRANCH at a higher speed than that of the ADVANCED level. This is the player’s car vs. a computer-driven car time trial race. When a player clocks a good time, they can record their name.

8 DAILY MAINTENANCE

8-1 Removing the Game Printed Circuit Board (PCB)

1. Remove the back door,
2. Remove two assembling bolts (M6 X 30), then pull out the power control panel about 25cm. (Note: if you pull it out too much, it will be detached).
3. Disconnect two connectors on the EMI board, then remove six cup screws (M4 X 10) from the shield case door. (Do not lose internal washers).
4. Take care not to damage the connectors between the EMI board and the main PCB to remove the shield case door, then take out the main pcb.
5. Remove two cup screws (M4 X 10) from the I/O door. (Note: Do not remove other screws).
6. Remove the I/O door, then disconnect four connectors of the I/O PCB.
7. Take out the I/O PCB.

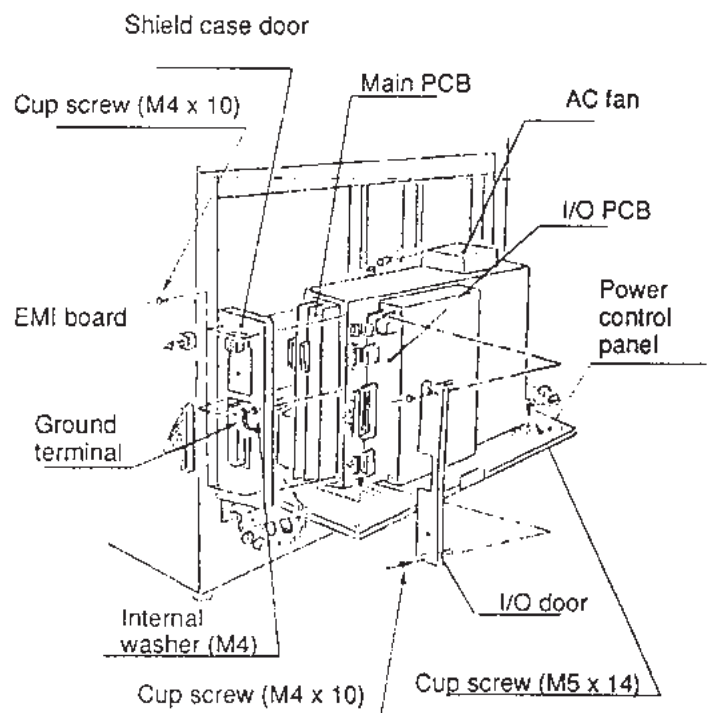
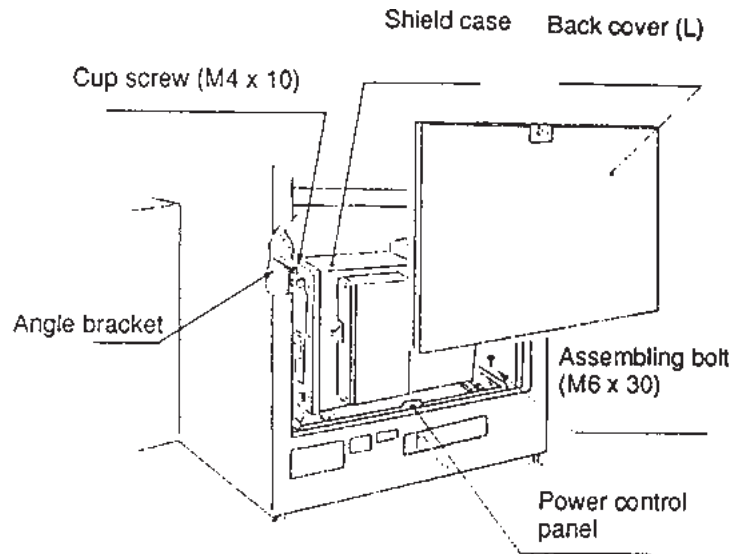

8-2 Removing the Shield Case

1. Perform Steps (1) and (2) described in [Section 8-1](#).
2. Disconnect the connector of the AC Fan.
3. Remove two cup screw (M5 X 14) then take out the shield case.

8-3 Removing the Power Control Panel

1. Perform steps 1, 2, 5 and 6 described in [Section 8-1](#).
2. Disconnect two connectors of the EMI board, remove a cup screw (M4 X 10) from the shield case door, then remove the ground terminal. (Note: do not lose the internal washer).
3. Disconnect the connectors connecting the power control panel and the main body assy: one connector on the right side and two connectors on the left side then remove the power control panel.

8-4 Signboard Assy

8-4-1 Replacing the Fluorescent Lamp

1. Remove five torque bolts (M5 X 12) from the signboard cover.
2. Disconnect two connectors of the flashlight, then remove the signboard cover.
3. Pull out the fluorescent lamp cover, then disconnect the ground terminal and the connector connected to the main body assy. (Note: do not lose the internal washer).
4. Pull out the fluorescent lamp fixing plate, then replace the fluorescent lamp (32W) with a new one.

8-5 Dashboard Assy (Replacing the Fluorescent Lamp)

1. Remove five torque bolts (M5 x 12) located on the right side of the dashboard, then the dashboard cover (R).
2. Remove one cup screw (M5 X 12) and disconnect one connector. Then pull out the FL bracket. To perform this operation, keep the right side of the main body 320cm distance from another machine.
3. Replace the fluorescent lamp (15W) with a new one.

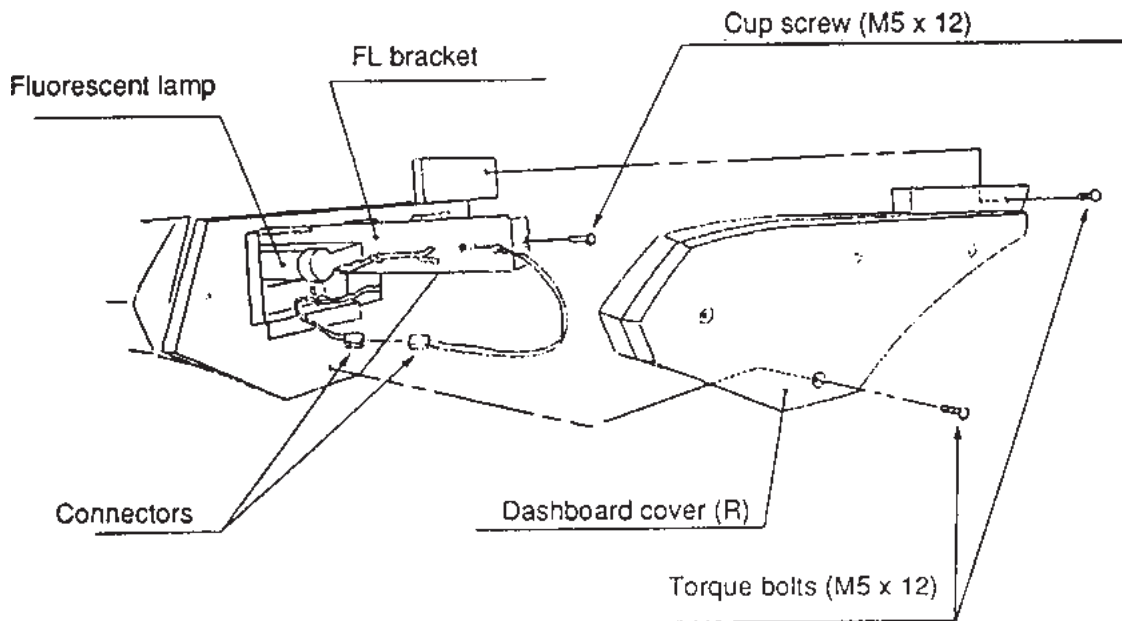

8-6 AB Pedal Assy (Replacing the Control)

1. Remove four hex head bolts (M6x20) and withdraw the assy forward .
2. Loosen the quadrant gear clamp screw and remove the quadrant gear.
3. Loosen the gear grub screw and remove the gear.
4. Replace the control potentiometer.

Note: When re-assembling

- a. Ensure that the potentiometer locating tag is engaged in the mounting plate cutout.
- b. Turn the potentiometer shaft almost fully clockwise before engaging the quadrant gear.

8-7 Clutch Pedal Assy (Replacing the Micro Switch)

1. Remove four hex head bolts (M6x20) and withdraw the assy forwards.
2. Replace the micro switch.

8-8 Steering Assy

8-8-1 Replacing the control

1. Remove four button head screws (M5x12), two on the steering column and two on the underside front. Loosen three button head screws (M5x12), from the underside rear, and remove the under cover vac-form.
2. Disconnect the four way connector.
3. Remove four hex head bolts (M10x20), two either side of the steering box assy.
4. Remove two hex head bolts (M10x20) under the steering column.

Warning: The steering assy is heavy and will drop when the two hex head bolts are removed, be ready to lower the assy.

5. Loosen the grub screw on the gear and remove the gear.
6. Replace the control potentiometer.

Note: When replacing the control potentiometer ensure that the locating tag of the potentiometer is located in the hole in the mounting bracket and the pot shaft is at its mid travel before tightening the gear grub screw.

7. Re-initialize the game ([See 6-4 Adjusting the Game - page 15](#)) before the game is played.

8-8-2 Replacing The Steering Wheel

1. Remove the centre cover of the steering wheel.
2. Remove three socket button heads (M6x16)
3. Pull off the steering wheel, then replace it with a new one.

8-9 Gear Shift Assy (removing)

1. Remove six button head screws (M6x16) and remove the boot cover plate.
2. Remove twelve button head screws (M6x16) and remove the shifter cover plate.
3. Disconnect the six way connector.
4. Remove four hex head bolts (M6x20) retaining the shifter base plate to the housing assy and remove the assy.

8-10 Replacing the Speaker

1. Remove eight torque bolts (M5 X 12) located on the side of the main body, then the monitor panel (R) or monitor panel (L).
2. Ensure the correct colour wire is re-connected to each speaker terminal when replacing speaker.

8-11 Replacing the Monitor

The monitor weighs approximately 60 kgs and it is recommended THAT AT LEAST TWO PEOPLE remove the monitor.

1. Remove 14 torque bolts (M6 X 16), then the rear cover.
2. Disconnect two connectors.
3. Remove two hexagonal bolts (M6 X 20), then take out the monitor from the main body as indicated by the arrow mark.
4. Replace the monitor with a new one.
5. To replace the rear cover, hook the stud bolt of the rear cover to the hole of the main body assy, then fix the rear cover to the main body assy with fourteen torque bolts (M6 X 16).

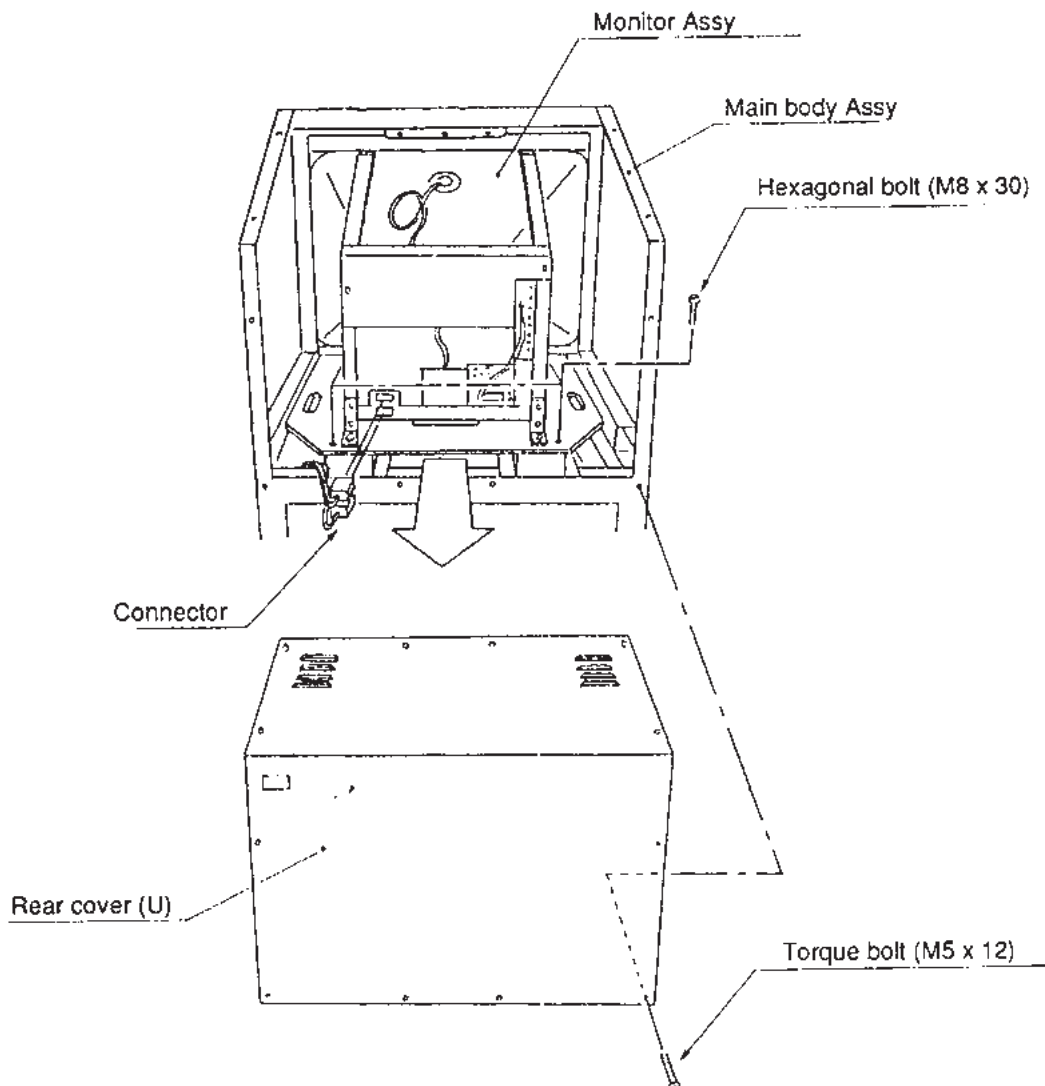

9. PARTS LIST

CABINET

DESCRIPTION	PART No
Monitor 33" Hantarex Polo	84000015
Speaker 4 1/2" 20w (with shield can)	62000006
Speaker - Piezo Horn	62000046
Accelerator/Brake Pedal Assy	88800021
Accelerator/Brake Control Pot (5k)	76000652
Clutch Pedal Assy	88800032
Steering Assy (340 degrees)	88800045
Steering Control Pot (5k)	76000652
Power Supply Assy - 5v/30amp	83000004
Schaffner Mains Filter Input Assy	66000016
Fan	67000015
Fluorescent Tube 18"	64500000
Choke 15w	63300000
100 Ohm 10w W/W Volume Control	76000164
M16 Adjustable Foot	88300079
75mm Castor	59000005

SEAT & BASE ASSY

DESCRIPTION	PART No
Seat - (black)	88300673
Seat Slider Mechanism	88300680
Speaker 4 1/2" 20w	62000006
Speaker Cover Plate (Left)	88300603
Speaker Cover Plate (Right)	88300604
6 Speed Gear Shift Assy	88300672
Gear Shift Leather Boot	88300683
Bull Bar (Polished S/Steel)	88300678
M16 Adjustable Foot	88300079
75mm Castor	59000005

VAC-FORM PLASTICS

DESCRIPTION	PART No
Side Speaker Cover (Left)	88300716
Side Speaker Cover (Right)	88300717
Screen Surround	88300720
Dashboard	88300722
Dashboard Under Cover	88300723
Dashboard Side Closing Cover (Left)	88300724
Dashboard Side Closing Cover (Right)	88300725
Steering Closing Cover	88300726
Header End Closing Cover (Left)	88300729
Header End Closing Cover (Right)	88300730

DECALS

DESCRIPTION	PART No
Side Speaker Cover-Ridge Racer (Left)	40000187
Side Speaker Cover-Ridge Racer (Right)	40000193
Gear Shift Upper (A)	40000188
Gear Shift Lower (B)	40000189
Seat Back-Ridge Racer/Twin Turbo	40000190
Namco	40000191
Twin Turbo	40000192

ACRYLICS

DESCRIPTION	PART No
Screen Top Hood (Smoked)	88300705
Speedo Front Cover	88300727
Battery/Oil Front Cover	88300728
Speedo Printed Polycarbonate	33000115
Battery/Oil Printed Polycarbonate	33000116
Ridge Racer Top Flash	30000058