

namco®

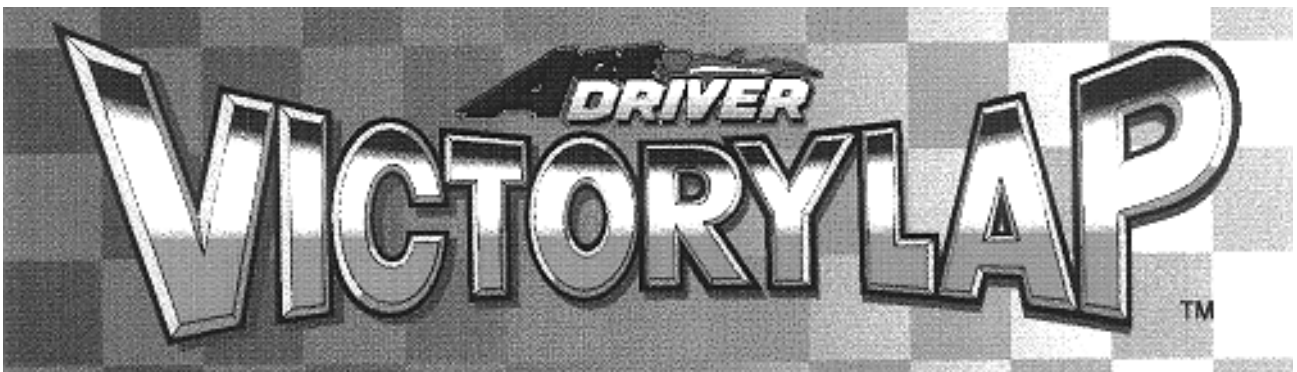

Operators Manual

IT IS THE RESPONSIBILITY OF THE OPERATOR TO MAINTAIN CUSTOMER SAFETY AT ALL TIMES, AND IT IS IMPERATIVE THAT THE DETAILS SET OUT IN THIS MANUAL ARE FOLLOWED PRECISELY,

Part No. 90500024

© 1996 **NAMCO LIMITED**. all rights reserved.

No part of this publication may be reproduced by any mechanical, photographic or electronic process, or in the form of phonographic recording, nor may it be stored in a retrieval system, transmitted or otherwise copied for public or private use, without permission from
NAMCO EUROPE LIMITED

While the information contained in this manual is given in good faith and was accurate at the time of publication, **NAMCO EUROPE LIMITED** reserve the right to make changes and alterations without notice.

This machine has been manufactured in accordance with European Community directives (1st. January 1996), and as such bears the **CE** marking. Any changes or modifications to this machine must be in accordance with European Community directives (1st. January 1996).

If you make any unauthorised changes to this product, you may contravene European Community directives (1st. January 1996).

Under some conditions of extreme external interference, e.g. radio transmissions, electrostatic discharge or mains borne transients, some degradation of performance may occur. However the machine will recover normal performance once the source of interference has ceased or been removed.

Published by:
NAMCO EUROPE LIMITED
Namco House,
8 Acton Park Estate,
The Vale,
London W3. 7QE

Phone: 0208-324-6000
Fax:- 0208-324-6010

SAFETY WARNING

In order to use this machine safely, be sure to read this operators manual carefully before installation, adjustment or use of this machine.

Whenever the owner of this machine entrusts disassembly, installation, adjustment or routine maintenance to another person, the owner should ensure that that person read the appropriate precautions and relevant sections of this manual before starting work.

In order that no accidents occur when the machine is in operation, strictly follow the notes on safety described below. Also, carefully read section (2), "Precautions".

Warnings for Operation (Ⓢ Requirements)

- NOTE:* Only operate this machine after checking that it has been installed correctly and in accordance with the Installation and Commissioning Manual.
- NOTE:* Parts of this machine move during game play, so there are places where the distance between the stationary section and moveable section changes. There are warning notices to keep hands and feet clear of moving parts, however if the operator feels that a person is in any danger, he should warn that person accordingly.
- NOTE:* The warning notices must always be kept in good condition and replaced if worn, so that the customer can read them clearly.
- NOTE:* **If there is an error or problem with the machine, operation must be stopped immediately and the problem rectified before any further use.**
- NOTE:* Installation, Service, Adjustments and Routine Maintenance should be carried out by qualified personnel only.

Warnings for Disassembly, Installation, Routine Maintenance and Troubleshooting.

- DANGER:* Namco Ltd. bears absolutely no responsibility for accidents, injury or damage resulting from unauthorized changes to this machine.
- DANGER:* Ensure that the machine has been turned **OFF** before making adjustments or carrying out maintenance. Also ensure only qualified personnel turn the power **ON** to this machine.
- DANGER:* The power supply and inside the monitor will remain hot and have areas of high voltage even though the machine has been turned OFF, and there is the possibility of burns or electric shock. Be careful not to touch these areas.
- DANGER:* In order to prevent injury due to mis-operation, be sure that the voltage of the main power supply is within the prescribed limits. Also to prevent possible electric shock due to failure, this machine **MUST** be fitted with a securely connected earthed plug.
- NOTE:* Do not turn the power switch **ON** until the machine has been installed correctly.

Contents

Operators Manual	1
SAFETY WARNING	3
1. SPECIFICATIONS	5
2. PRECAUTIONS	6
2-1 Cautions when Transporting.	6
2-2 Cautions when Handling.	6
2-3 Cautions when Operating	6
2-4 Cautions when Installing	7
3. HOW TO PLAY	8
4. MAJOR COMPONENTS	10
5. INSTALLATION	11
5-1 Connecting the Seat Assemblies to the Main Cabinet	11
5-2 Adjusting the Level Adjusters	11
6. LINKING TWO OR MORE MACHINES	12
6-1 Setting the Link Switches	13
7. ADJUSTMENTS	14
7-1 Turning on the Power	14
7-2 Adjustment Switches	14
7-3 Test Mode	15
7-3-1 Coin Options	16
7-3-2 Game Options	17
7-3-3 I/O Test	19
7-3-4 Switch Test	20
7-3-5 Motor Test	21
7-3-6 Lamp Test	21
7-3-8 Monitor Test	22
7-3-7 Sound Test	22
7-4 Adjustments When Replacing Parts (Initialization)	23
8. MAINTENANCE	24
8-1 Replacing the Fluorescent Lamp	24
8-2. AB Pedal Assembly	25
8-2-1. Removing the AB Pedal Assembly	25
8-2-2 Replacing the Control Pots.	25
8-3. Shift Assembly Maintenance	26
8-4 Steering assembly Maintenance	26
8-4-1 Replacing the Control Pot	27
8-4-2 Replacing the Drive Belt or Steering Motor	27
9. PARTS	28
10 SHEMATIC	34

1. SPECIFICATIONS

POWER SUPPLY :- 230volts AC

MONITOR :- Hantarex 28" Polo Colour Monitor with auto degauss.

COIN ACCEPTOR:- Mars CashFlow - 4 Channel

DIMENSIONS :-

Assembled	1396(w) x 1700(d) x 1870(h)
Monitor Cabinet	1396(w) x 760(d) x 1870(h)
Seat Assembly	470(w) x 940(d) x 1230(h)

WEIGHT :-

Assembled	310kg
Monitor Cabinet	250kg
Seat Assembly	30kg

ACCESSORIES :-

Keys:	(Cash Door) 2
	(Coin Door) 2
	(Back Door) 2ea
	IEC Mains Lead 1
	Operators Manual 1
	Monitor Manual 1
	Cashflow Manual 1
	Link Cable 1
	Seat/Cabinet Joint Bracket 4
	M10x35 Hex Head Set Screw 24
	M10 Spring Washer 24
	M10 Flat Washer 24
	M5 Security Wrench 1

2. PRECAUTIONS

2-1 Cautions when Transporting.

- a. Do not subject the game to physical shock when transporting or moving it.
- b. Always return the levellers to the UP position before moving the machine.
- c. Take care not to rope any moulded (plastic) parts when transporting.
- d. Always separate the seat assemblies from the cabinet before moving or transporting the machine.
- e. The main cabinet has a high centre of gravity, take care that the machine is balanced if using a fork lift.

2-2 Cautions when Handling.

- a. AC power must always be turned OFF, and the game disconnected, before replacing any parts or connecting/disconnecting connectors.
- b. When unplugging the game from an electrical outlet, always grasp the plug, not the mains lead.
- c. The machine **must be earthed** with a securely connected earthed plug.
- d. Care must be taken at all times to avoid electric shock when inspecting or adjusting the game.

2-3 Cautions when Operating

- a. Only parts specified by Namco Ltd. should be used when replacement is necessary.
- b. Only operate the machine after checking that has been installed in accordance with the installation details (See 2-4 "Cautions when Installing")
- c. Adjustment is required whenever the game PCB board, ROM, Steering Assy, Accelerator/Brake Assy or Controls are replaced. (See 7-4 "Adjusting the Game After Replacing Parts" on page 19)
- d. Always turn power OFF before performing any maintenance or adjustments.
- e. The Switch Mode Power Supply and Monitor Chassis may still be hot and retain high voltage after the power has been turned OFF, take care not to touch these areas.
- f. Before performing any work not described in this manual, contact your dealer for instructions.

2-4 Cautions when Installing

This machine is designed for indoor use only. The game **must not be installed outdoors** or under the following conditions:-

- a. In areas directly exposed to sunlight, high humidity, direct water contact, dust, high heat or extreme cold.
- b. In locations that would present an obstacle in the case of an emergency, ie. near fire equipment or emergency exits.
- c. On an unstable or uneven surface, or subject to floor vibration.
- d. To allow sufficient access, ensure that there is at least 300mm each side between other machines or walls and 500mm at the rear.
(Note: If the other machine is another Victory Lap there is no need to leave a gap between machines.)

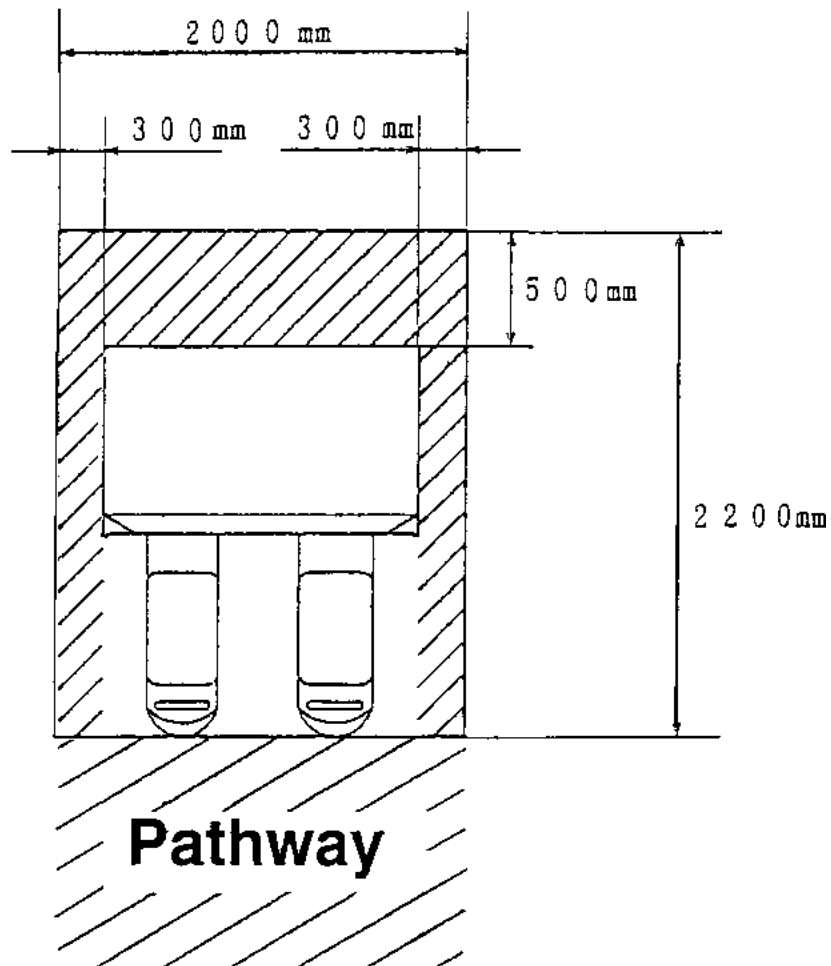

3. HOW TO PLAY

- This machine is a multi-player racing game that allows several people to play at the same time, up to a maximum number of eight.
- When two or three players are competing against each other, a computer car is included and competition is between four cars.
When only one player is playing, he/she competes against the computer cars.
When four or more players compete against each other, competition is amongst those players only.
- In the case of linked play, the "Championship Point Mode" functions and players are able to carry over their individual race points for up to three games.

[Game Summary]

- The object of the game is to complete the set number of laps as fast as possible within the set time.
- The game is over after completing the set number of laps. The finishing position, lap time, and total time are displayed at the end of the game.
- If the set time runs out (becomes "0") before the laps are completed, the game is over.

[Championship Point Mode]

- At the end of a game, the race ranking, total points acquired and points ranking are displayed.
The participating players are awarded points according to the final position for each race. Also, points are awarded during the race to the lap leader (player leading at the start of each lap). In this way, points are accumulated every race.
- After the first or second game, only those players that continue are included in the points accumulation.
The shift type and the race class for the next race are the same as the previous race, however the course is selected automatically.
If only one player continues, no points are awarded.
- At the end of the third race, the final accumulated points ranking is displayed and the game is over.

[Starting the Game]

- Insert a coin/s. Move the shift lever up or down to select the course. SEROW VALLEY (High speed course), STREAM FIELD (semi-technical course), CAPITAL CITY CIRCUIT (Technical course). Then depress the accelerator
- Next, move the shift lever up or down to select the level of difficulty (beginner, expert, expert (pro)) and then depress the accelerator.
- Finally, move the shift lever up or down to select the method of gear shifting, AT (auto) or MT (manual) and then depress the accelerator.

- After making selections, wait for the empty seat entry.
- A linked game starts when all of the connected seats have been entered, or twenty seconds after the first coin/s have been inserted.
If there is no entry by another person within the twenty seconds, the game starts as a single player.
- A single player game can be started without waiting for other players by inserting a coin/s while pressing the view change button.

4. MAJOR COMPONENTS

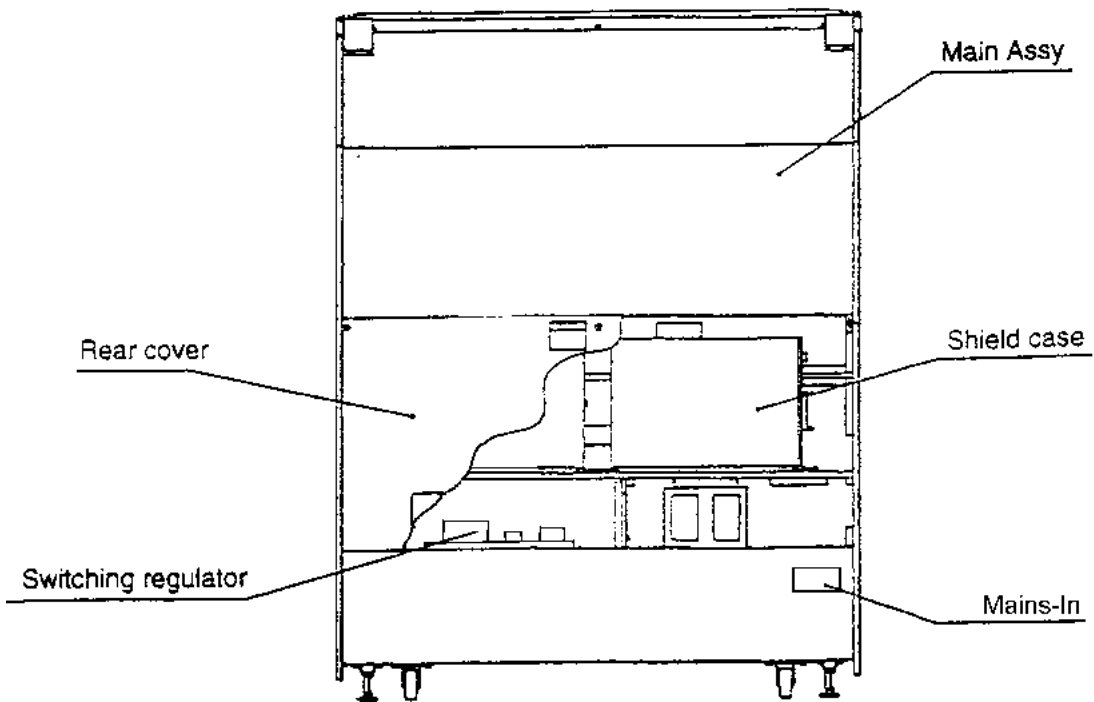
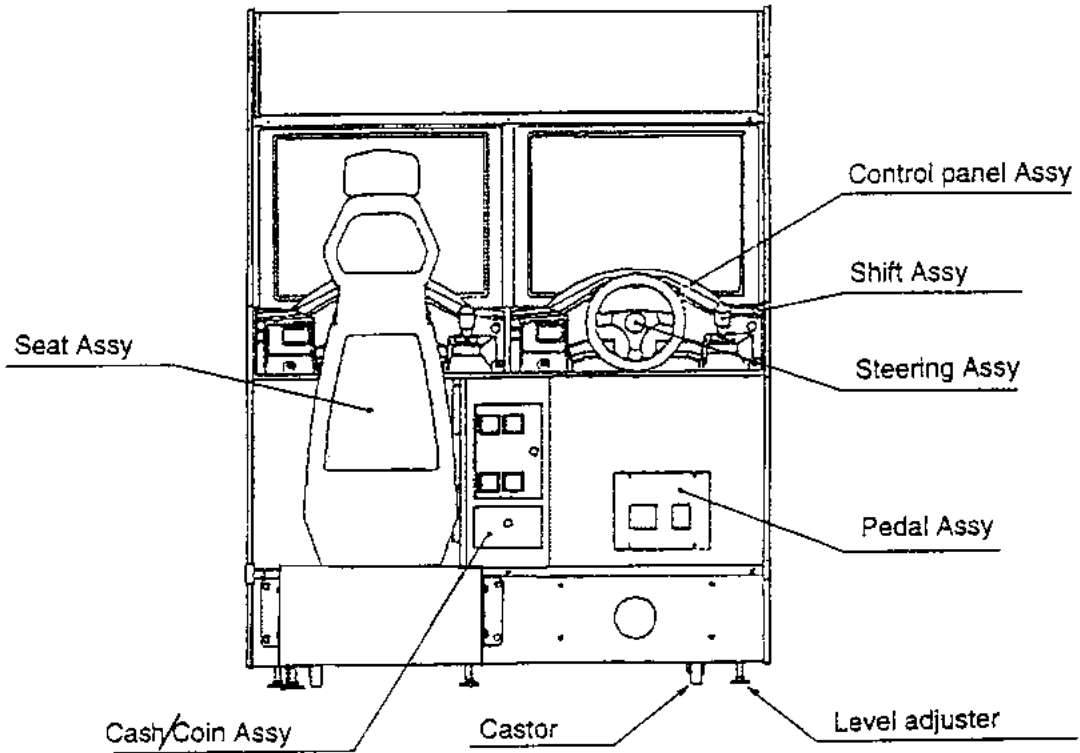

5. INSTALLATION

5-1 Connecting the Seat Assemblies to the Main Cabinet

- a. Place the main cabinet in its final position.
- b. Connect the connectors between the Seat Assembly and Main Cabinet.
- c. Fix the Seat Assemblies to the Cabinet using the Joint Plates, M10 hex head screws, flat washers and spring washers taking care not to trap any wires between the Seat Assembly and Cabinet.

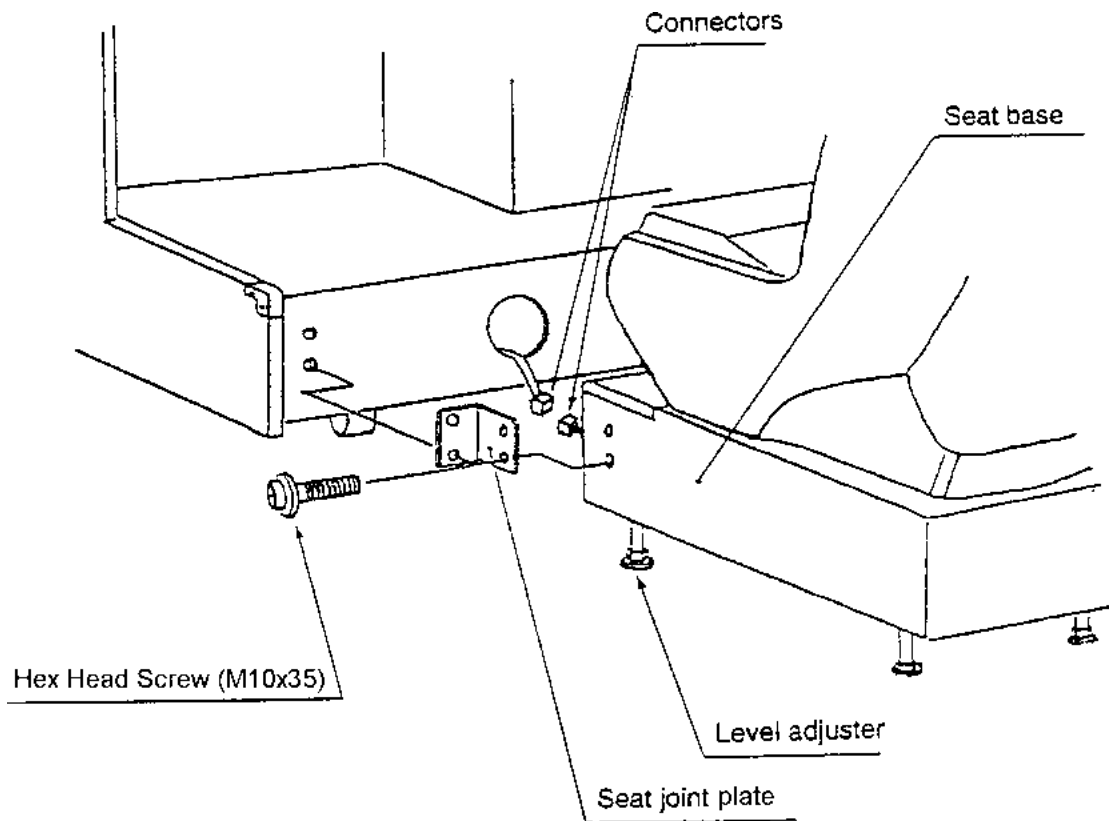

5-2 Adjusting the Level Adjusters

When the seats have been assembled to the main cabinet, lower the level adjusters, (4 on the main cabinet and 4 on each seat assembly), with a spanner so that all castors are raised from the floor and the machine is level.

Tighten the lock nuts with a spanner to ensure that the level adjusters do not move.



6. LINKING TWO OR MORE MACHINES

Up to four machines (8 seats) can be linked together.
The machines should be linked as described below.

NOTE: Each machine can draw up to 3 amps. Make sure that the power supply is adequate.

- Ensure that the power is "OFF".
- Loosen the two screws (M4x10) on the back of the main cabinet, and remove the connector cover.

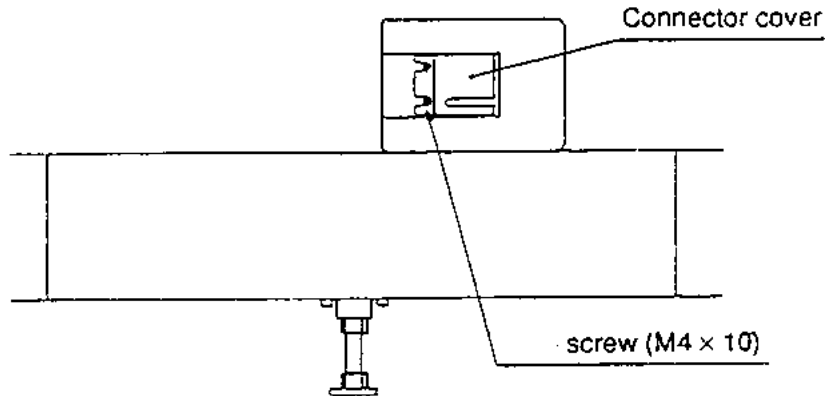

- Set the link switches to "ON" , "EXT" , and "ON". (See Diag.)
- Use the supplied link cable and connect the machines between "IN" and "OUT" sockets (See Diag.)

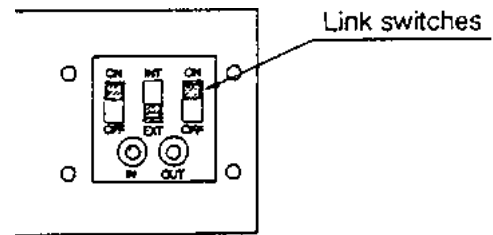

[Examples of Linked Machines]

- 2 Machines
(4 Seats)

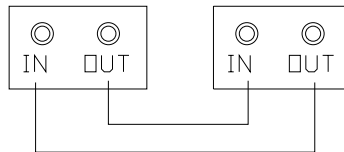

- 3 Machines
(6 Seats)

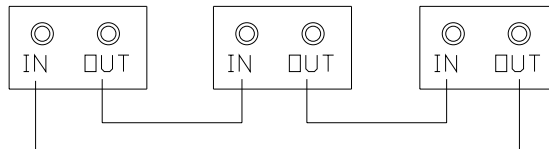

- 4 Machines
(8 Seats)

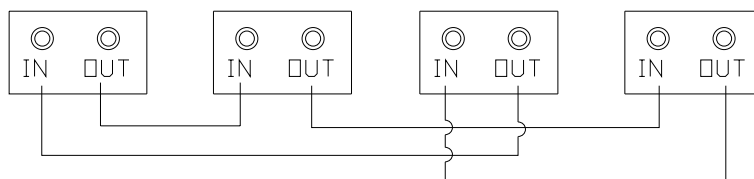

- e. Turn the power to each machine "ON", and set the PCB ID using the test mode. (Refer to section 7-3-2 "Setting the Game Options" (page17))

Note: Settings other than those described will cause the machine to operate incorrectly.

6-1 Setting the Link Switches

The link switches are used to set the connection between seats and machines.

- a. Setting only one machine (2 seats)

Set the link switches to "ON", "INT", and "ON".

Note: Do not use a link cable.

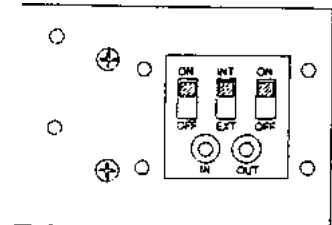

- b. Setting two or more machines.

Set the link switches to "ON", "EXT", and "ON".

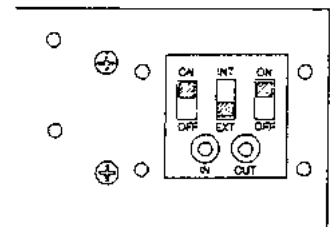

- c. Install the connector cover using the two screws (M4x10).

The link procedure is now complete.

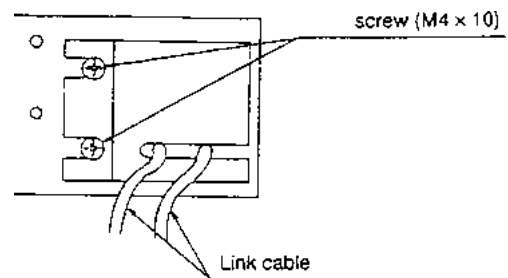

- d. Setting for faulty PCB.

If the game PCB of only one side is faulty, set the link on that side to "OFF"

[Example of setting for faulty left side]

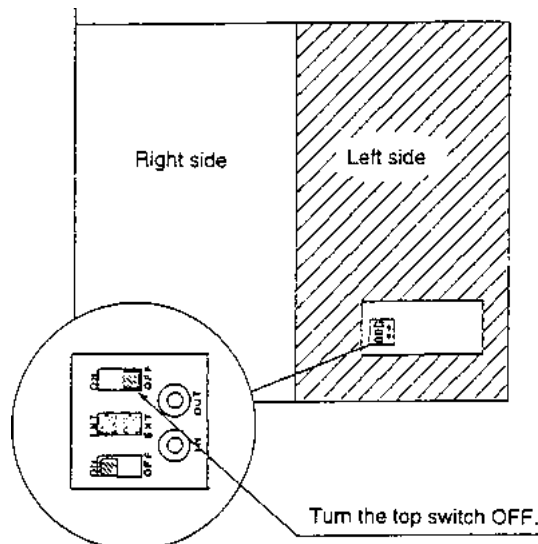

7 ADJUSTMENTS

7-1 Turning on the Power

After the machine has been installed, turn ON the power. The Power switch is located on the rear of the Main cabinet. (See section 4 "Major Components" (page 10).)

7-2 Adjustment Switches

The adjustment switches are located inside the coin door.

1. Service Switch
Press this switch to obtain game credits without incrementing the play meters.
2. Test Switch
Slide this switch "ON" to enter test mode.
Test mode allows game testing and the changing of game settings. (Refer to section 7-3 "Test Mode" (page 15).)

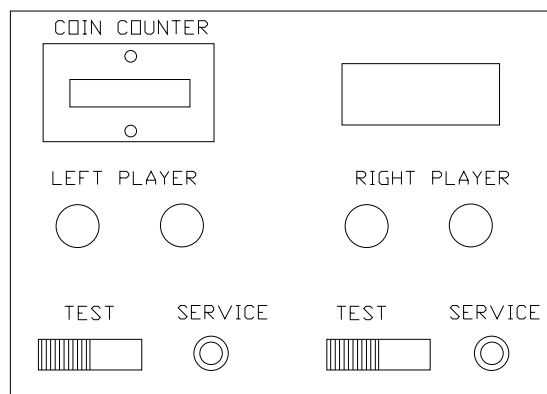

Service Bracket

7-3 Test Mode

1. Open the coin door and slide the test switch "ON". The "Menu Screen" will be displayed on the monitor.
2. Select the test required by moving the shift lever up or down. The colour of the selected test will change.
3. Enter the selected test by stepping on the accelerator. Select "EXIT" to return to the "Menu Screen" (step on the accelerator when using the monitor test screen).
4. After testing is completed, ensure that the test switch is returned to the "OFF" position to return to game mode.

The Test Switch must always be in the "OFF" position for normal game mode.

MENU	
COIN OPTIONS	----- (1) Sets the price of play. (See 7-3-1)
GAME OPTIONS	----- (2) Sets the game options. (See 7-3-2)
I/O TEST	----- (3) Used for testing the switches and motor. (See 7-3-3)
MONITOR TEST	----- (4) Used for adjusting the monitor. (See 7-3-8)
SOUND TEST	----- (5) Used for adjusting the speaker volume. (See 7-3-7)
ADS DATA	----- (6) Displays the accumulated game data.
OTHERS	----- (7) Used for testing the PC boards and for initializing all of the settings.
GAS: ENTER	SHIFT: CHOOSE

7-3-1 Coin Options

- a. Select item (1) "COIN OPTIONS" on the menu screen, to set the game cost and related settings.
- b. Use the shift lever to select the required item then step on the accelerator.
- c. Use the shift lever to change the settings then step on the accelerator to store the new values.
- d. Select "EXIT" to return to the menu screen.

COIN OPTIONS [DEFAULT IN GREEN]

GAME COST
1 COIN 1 CREDIT (a)

COIN1 MECH VALUE
1 COIN COUNT AS 1 COIN (b)

COIN MECH 2 VALUE
1 COIN COUNT AS 1 COIN (c)

BONUS FOR QUANTITY BUY IN
NONE (d)

FREE PLAY
OFF (e)

EXIT

GAS: ENTER SHIFT: CHOOSE

Note:- The price of play on this machine is set within the Cashflow Coin Mech. Ensure that the Coin Options on the screen are set as shown in the following table.

ITEM	CONTENTS	FACTORY SET
(a) Game Cost	Coins required for 1 credit - - - - - settable 1 - 9	1
(b) Coin 1 Mech Value	Number of pulses on meter per coin - - - - - settable 1 - 9	1
(c) Coin 2 Mech Value	Number of pulses on meter per coin - - - - - settable 1 - 9	1
(d) Bonus Coin	Extra coin pulse at specified coins in	NONE
(e) Free Play	Game started by pressing accelerator - - - - - Yes/No	NO

7-3-2 Game Options

- a. Select item (2) "GAME OPTIONS" on the menu screen to set the game options.
- b. Use the shift lever to select the required item then step on the accelerator.
- c. Use the shift lever to change the settings then step on the accelerator to store the new values.
- d. Select "EXIT" to return to the menu screen.

GAME OPTIONS [DEFAULT IN GREEN]				
PCB ID NUMBER	1		 (a)
TEAM COLOUR	BLUE	3	 (b)
COURSE	SEROW VALLEY		 (c)
RACE CLASS	BEG	EXP	PRO (d)
SOLO DIFFICULTY	B	B	B (e)
SOLO RACE LAPS	3	3	3 (f)
LINK DIFFICULTY	B	B	B (g)
LINK RACE LAPS	3	3	3 (h)
SPEED DISPLAY		KM/H	 (i)
SOUND IN ATTRACT		ON	 (j)
EXIT				
GAS: ENTER		SHIFT: CHOOSE		

(See page 14 for descriptions)

NOTES

- **The rank (level of difficulty) and number of laps must be set the same on all positions that are linked.**
- **The PCB number of the seat furthest left (when facing the front of the machine) should be set to 1, and the other seats set to 2, 3, 4 and so on in order from left to right. The PCB number of the farthest right position should equal the number of positions linked.**
- **Settings other than those described will cause the machine to operate incorrectly.**

ITEM			DESCRIPTION		FACTORY SET	
(a) PCB Number			The PCB number should be set so that none of the linked positions have the same number			
(b) Team Colour			RED 25 or 26 BLUE 3 or 4 YELLOW 17 or 18 GREEN 11 or 12 * When more than three sets (6 seats) are linked, different race numbers should be used for the same team colours.			
(c) Course	SEROW VALLEY	(d) Race class	BEG	(e) Game difficulty (Solo time)	A (long) to D (short)	B
				(f) Number of laps (Solo game)	2 to 6	3
				(g) Game difficulty (Linked game)	A (long) to D (short)	B
				(h) Number of laps (Linked game)	2 to 6	3
			EXP	(e) Game difficulty (Solo time)	A (long) to D (short)	B
				(f) Number of laps (Solo game)	2 to 6	3
				(g) Game difficulty (Linked game)	A (long) to D (short)	B
				(h) Number of laps (Linked game)	2 to 6	3
			PRO	(e) Game difficulty (Solo time)	A (long) to D (short)	B
				(f) Number of laps (Solo game)	2 to 6	3
				(g) Game difficulty (Linked game)	A (long) to D (short)	B
				(h) Number of laps (Linked game)	2 to 6	3
	STREAM FIELD	(d) Race class	BEG	(e) Game difficulty (Solo time)	A (long) to D (short)	B
				(f) Number of laps (Solo game)	2 to 6	3
				(g) Game difficulty (Linked game)	A (long) to D (short)	B
				(h) Number of laps (Linked game)	2 to 6	3
			EXP	(e) Game difficulty (Solo time)	A (long) to D (short)	B
				(f) Number of laps (Solo game)	2 to 6	3
				(g) Game difficulty (Linked game)	A (long) to D (short)	B
				(h) Number of laps (Linked game)	2 to 6	3
			PRO	(e) Game difficulty (Solo time)	A (long) to D (short)	B
				(f) Number of laps (Solo game)	2 to 6	3
				(g) Game difficulty (Linked game)	A (long) to D (short)	B
				(h) Number of laps (Linked game)	2 to 6	3
CAPITAL CITY	(d) Race class	BEG	(e) Game difficulty (Solo time)	A (long) to D (short)	B	
			(f) Number of laps (Solo game)	2 to 6	3	
			(g) Game difficulty (Linked game)	A (long) to D (short)	B	
			(h) Number of laps (Linked game)	2 to 6	3	
		EXP	(e) Game difficulty (Solo time)	A (long) to D (short)	B	
			(f) Number of laps (Solo game)	2 to 6	3	
			(g) Game difficulty (Linked game)	A (long) to D (short)	B	
			(h) Number of laps (Linked game)	2 to 6	3	
		PRO	(e) Game difficulty (Solo time)	A (long) to D (short)	B	
			(f) Number of laps (Solo game)	2 to 6	3	
			(g) Game difficulty (Linked game)	A (long) to D (short)	B	
			(h) Number of laps (Linked game)	2 to 6	3	
(i) Speedo Units			KM/H / MPH		MPH	
(j) Attract Sound			ON / OFF		ON	

7-3-3 I/O Test

1. Select item (3) "I/O TEST" on the menu screen.
2. Use the shift lever to select the required item then step on the accelerator.

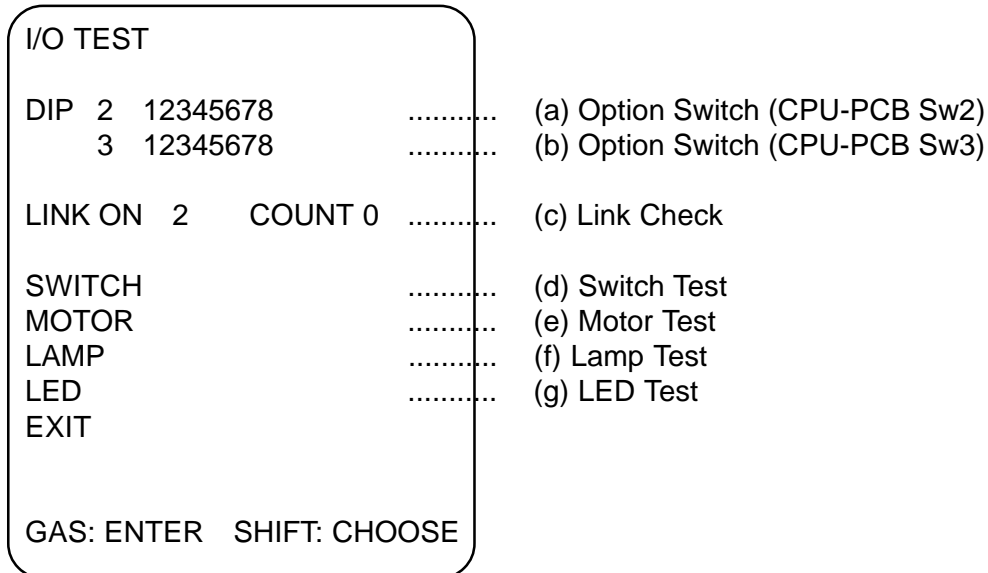

- (a) Displays the state of the option switch, SW2, on the game PC board (CPU-PCB).
- (b) Displays the state of the option switch, SW3, on the game PC board (CPU-PCB).
For both items (a) and (b), the switch is ON when the numbers are shown in red.
- (c) Displays the number of positions linked. If there is a link error, "ERROR" is displayed. The numbers to the right of "COUNT", display the number of link errors detected during the I/O test.
- (d) Tests the switches. ([See 7-3-4.](#))
- (e) Tests the motors. ([See 7-3-5.](#))
- (f) Tests the lamps. ([See 7-3-6.](#))
- (g) Unused

7-3-4 Switch Test

The following screen is displayed when "SWITCH" is selected on the I/O screen.

I/O TEST	
DIP	2 12345678 3 12345678
LINK ON 2	COUNT 0
SWITCH	
(a) Accelerator	GAS: *0000 COIN 1: OFF
(b) Brake	BRAKE *0000 COIN 2: OFF
(c) Steering	STEER *0000 SERVICE: OFF
(d) Shift	SHIFT CENTRE VIEW: OFF
	EMERGENCY: OFF
	(e) Coin 1 switch
	(f) Coin 2 switch
	(g) Service switch
	(h) View change switch
	(i) Emergency stop switch
TO EXIT, STEP ON GAS AND SHIFT UP	

- (a) When the accelerator is depressed, the number increases in the + direction.
- (b) When the brake is depressed, the number increases in the + direction.
- (c) When the steering wheel is turned to the right, the number increases in the + direction, and when it is turned to the left, it increases in the - direction.
When items (a), (b), and (c) are in their middle position, "0000" is displayed. (It is normal for the last digit to change.) Just before the steering wheel is as far as it will go, or just before stepping on the accelerator or brake as far as they will go, "OK" will be displayed to the right of the number if everything is correct.
- (d) Displays the position of the shift lever (CENTRE, UP, DOWN)
When the shift lever is pressed forward, switch 1 goes "ON" and "DOWN" is displayed, and when it is pulled back, switch 2 goes "ON" and "UP" is displayed.
- (e) When coin 1 switch is operated, "ON" is displayed.
- (f) Unused.
- (g) Goes "ON" when the service switch inside the coin door is pressed.
- (h) Goes "ON" when the view change button is pressed.
- (i) Unused

To return to the menu screen, move the shift lever up and step on the accelerator.

7-3-5 Motor Test

Note: Performing the steering motor test can be dangerous, sit on the seat properly, and take hands off the steering wheel.

The following screen is displayed when "MOTOR" is selected on the I/O screen.

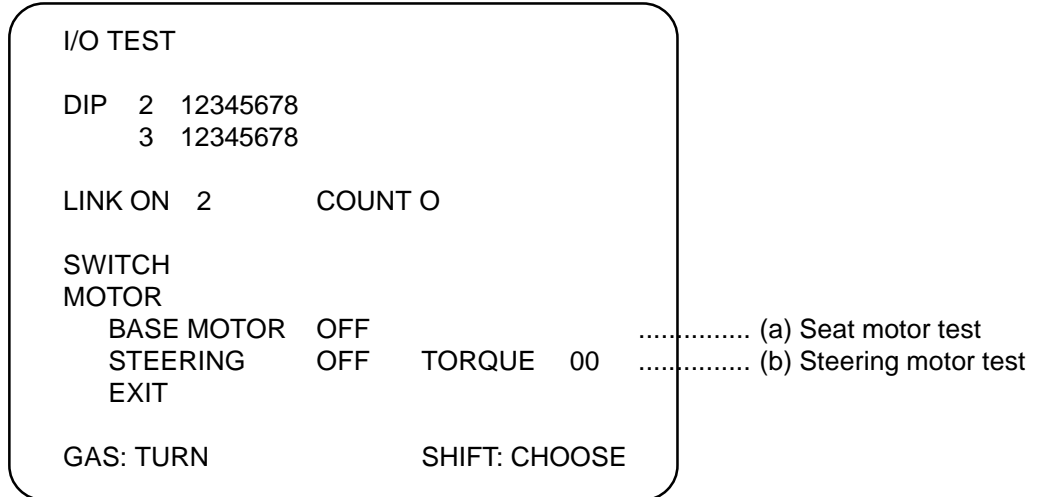

(a) Unused

(b) Tests the steering feedback motor.

When "STEERING" is selected and the accelerator is pressed the test is "ON" and the motor will start and turn the steering wheel left and right.

Pressing the accelerator again turns the test "OFF" and the motor will stop.

Select "EXIT" to return to the I/O test screen.

7-3-6 Lamp Test

The following screen is displayed when "LAMP" is selected on the I/O screen.

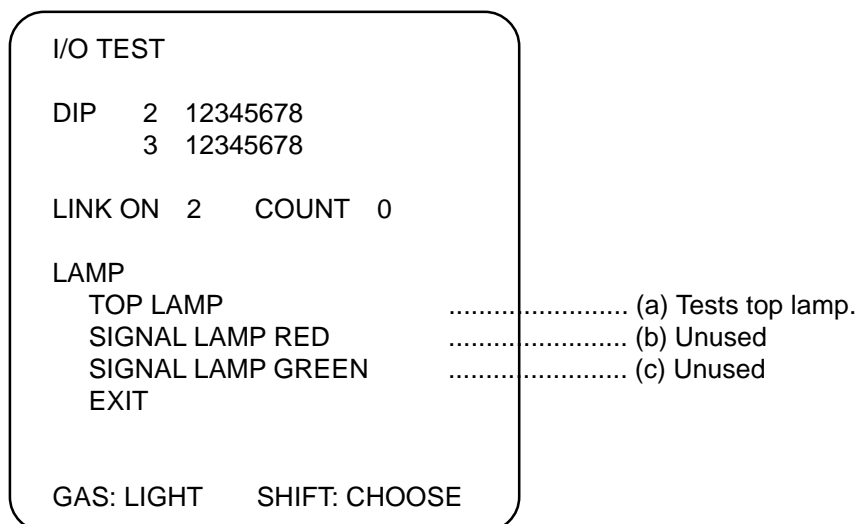

Select "EXIT" to return to the I/O test screen.

7-3-7 Sound Test

To adjust the sound volume, select "SOUND TEST" in the menu screen. The following screen will be displayed.

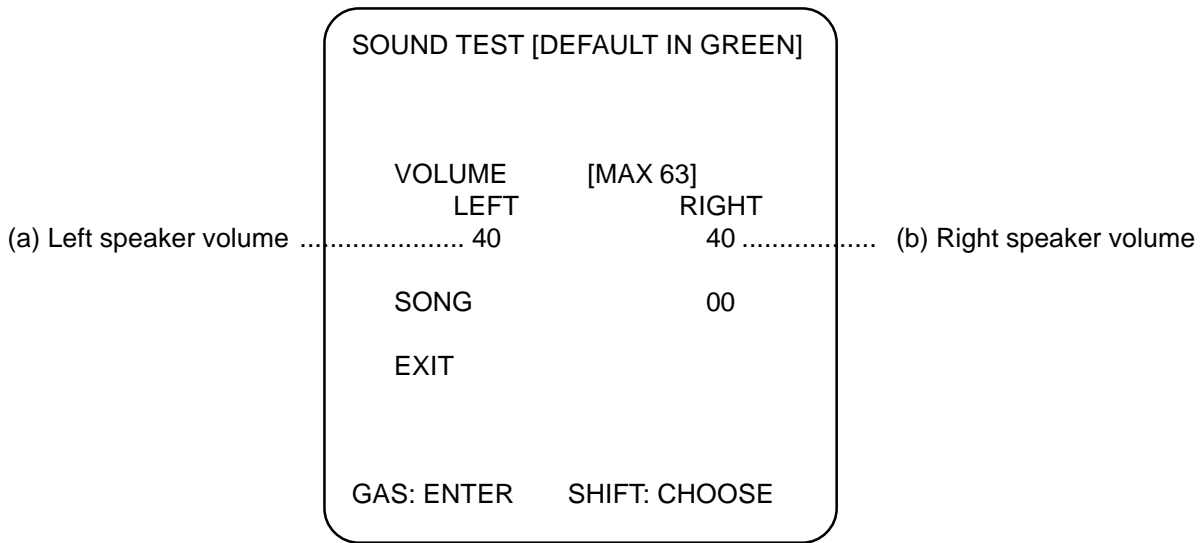

Select (a) or (b) by using the shift lever, the characters will blink in red, when the accelerator is pressed the numbers will start to blink. Moving the shift lever up will increase the number, moving the shift lever down will decrease the number.

The volume can be adjusted in 64 steps, with 00 the quietest and 63 the loudest. The factory setting is "40"

Select "EXIT" to return to the menu screen

7-3-8 Monitor Test

- a) Select item (5) "Monitor Test" on the menu screen to set up and adjust the monitor.
- b) On entering monitor test, the screen will display one of the following test patterns.

GRADATION PATTERN
CROSSHATCH GREEN
CROSSHATCH WHITE
WHITE WINDOW (H)
WHITE WINDOW (M)
WHITE WINDOW (L)
INTERLACE PATTERN
VIEW ANGLE ADJUST (CRT)
VIEW ANGLE ADJUST (PROJ)
FULL WHITE

- c. Use the shifter to change to the next pattern and accelerator to return to Main Menu.

7-4 Adjustments When Replacing Parts (Initialization)

The following adjustments should always be performed after replacing the game PC board, ROM, Steering Assy, Pedal Assy, or Control Pots.

The game will not operate correctly if these adjustments are not made.

- a) Ensure that accelerator and brake pedals are fully returned.
- b) Place the steering wheel to it's centre position and remove hands from the wheel
(*The steering wheel does not return to centre by itself.*)
- c) Slide the test switch "ON" while pressing the service switch. The following screen will be displayed on the monitor.

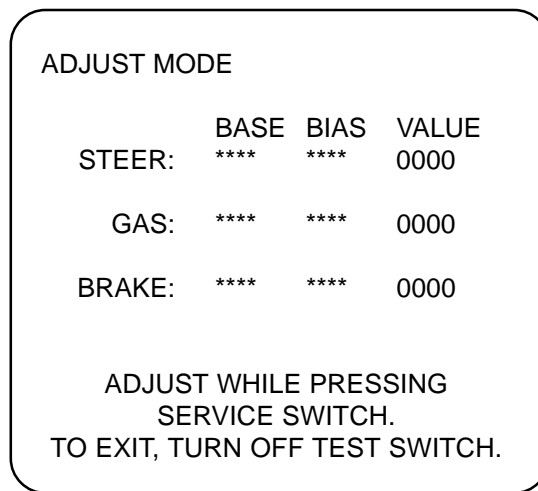

- d) Press the service switch to reset all values to 0000
- e) Fully depress and release the accelerator, then the brake, then turn the steering wheel fully left and right.
- f) Slide the test switch "OFF" to return to normal game mode.

Note: If the above initialization does not perform correctly, repeat two or three times.

8. MAINTENANCE

8-1 Replacing the Fluorescent Lamp

- 1) Remove four Security Button Head Screws (M4x25) and washers from the top of the header acrylic.
- 2) Remove four Security Button Head Screws (M4x25) from the Acrylic/Glass retaining bracket, and remove the bracket.
- 3) Remove the Header Acrylic.
- 4) Replace the Fluorescent Tube.

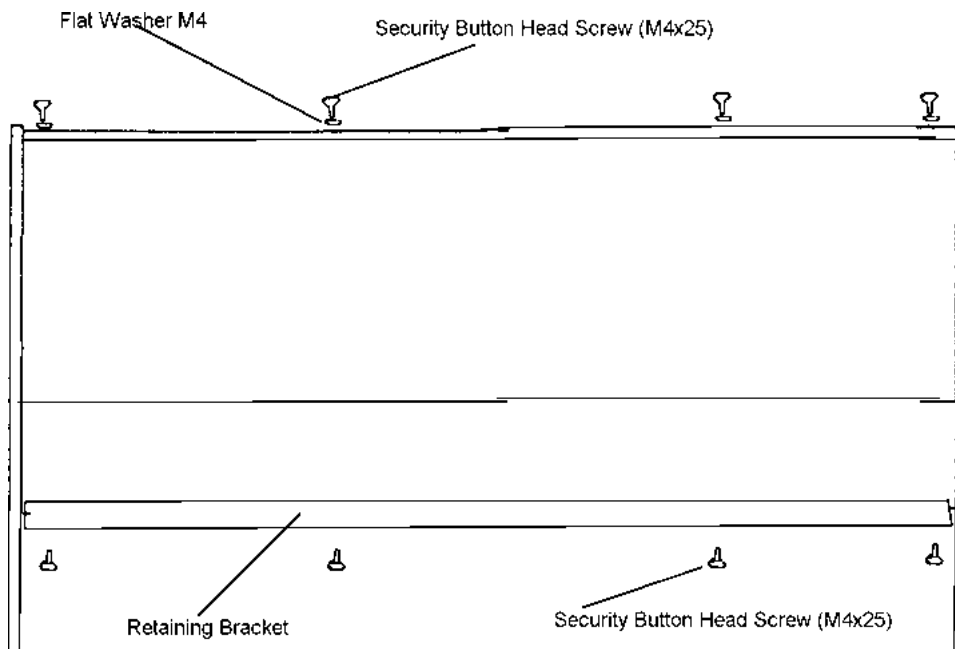

8-2. AB Pedal Assembly

8-2-1. Removing the AB Pedal Assembly

- 1) Remove the four security screws (M6x25), and withdraw the assembly forward.
- 2) Disconnect the connector, and remove the assembly.

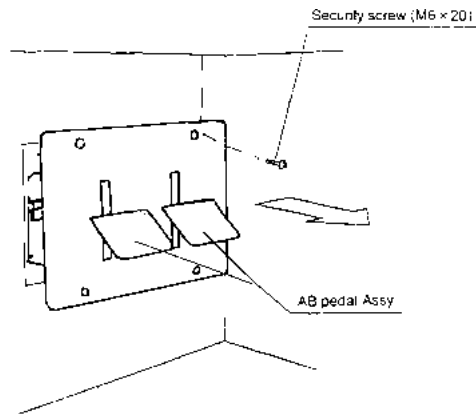

8-2-2 Replacing the Control Pots.

- 1) Loosen the quadrant gear clamp screw, and remove the quadrant gear.
- 2) Loosen the gear grub screw, and remove the gear.
- 3) Replace the control pot.

Note: When replacing the control pot

- a. Ensure that the potentiometer locating tag is engaged in the mounting plate hole.
- b. Turn the potentiometer shaft almost fully clockwise before engaging the quadrant gear.

After replacing the Control the game must be re-initialized (See section 7-4 "Adjustments when Replacing Parts")

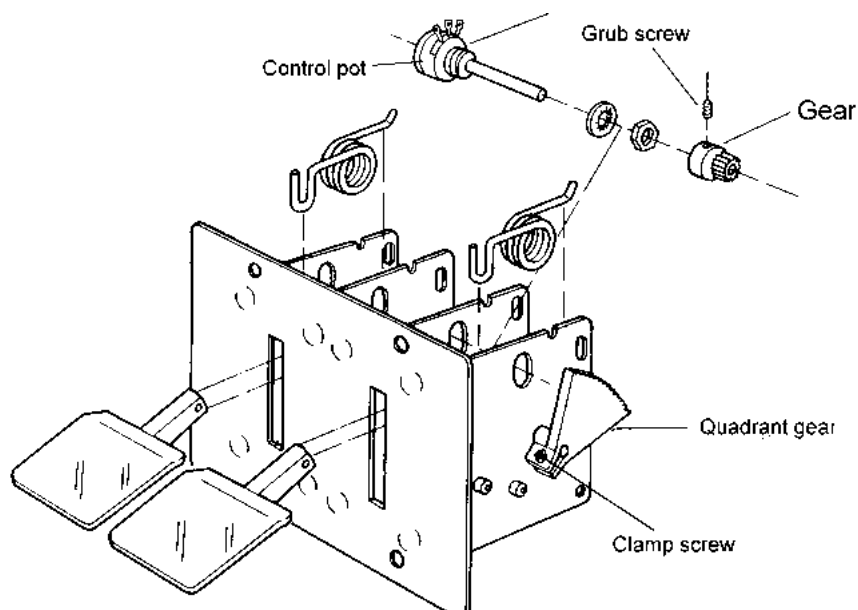

8-3. Shift Assembly Maintenance

- 1) Removing the Shift assembly
 - a). Remove the four security screws (M6x16), and withdraw the shift assembly.
 - b). Disconnect the connector.

- 2) Replacing the Microswitch
 - a). Remove the two pozi head screws (M3x16), and replace the switch.
 - b). Ensure that the switch is refitted the correct way round and the wires are fitted to correct terminals.

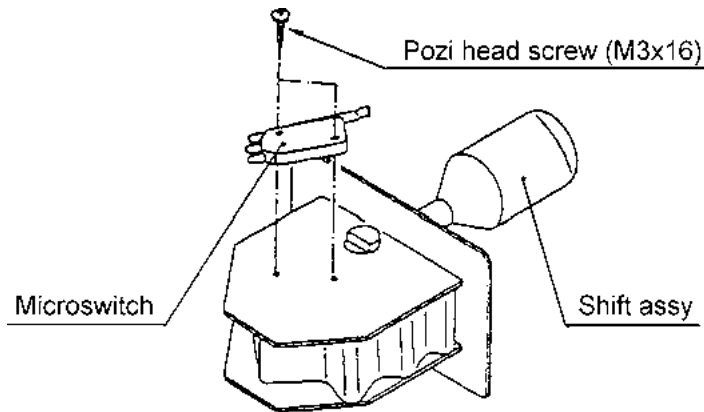

8-4 Steering assembly Maintenance

- 1) Remove four Security Screws (M6x25) and hinge the play panel forward and down.

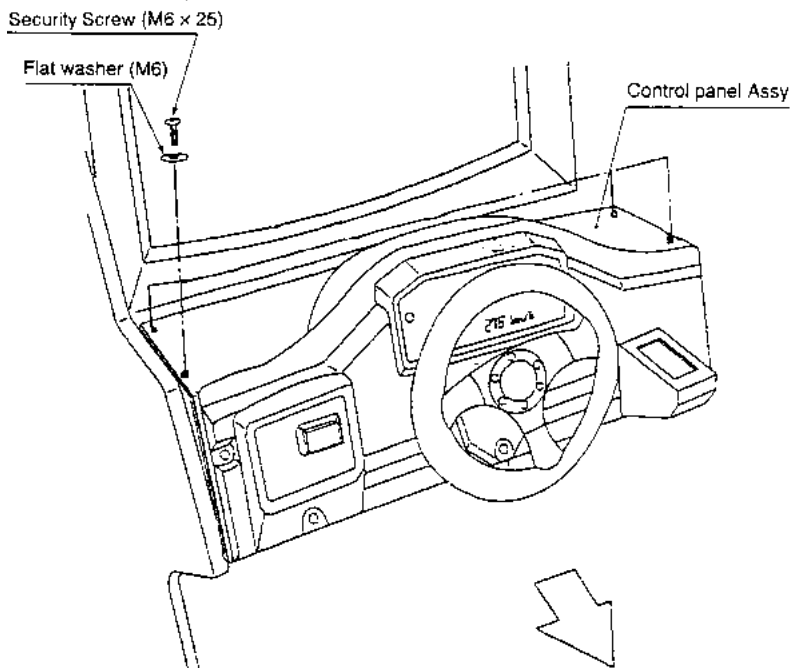

8-4-1 Replacing the Control Pot

- 1) Disconnect the Control Pot connector.
- 2) Loosen the grub screw . *Take care not to remove the screw completely.*
- 3) Loosen the pozi head screw retaining the Control Pot bracket and remove the bracket with the Control Pot .
- 4) Replace the Control Pot.

Note: Before re-tightening the grub screw ensure that it engages on the flat of the pot shaft.

After replacing the Control the game must be re-initialized (See section 7-4 "Adjustment when Replacing Parts").

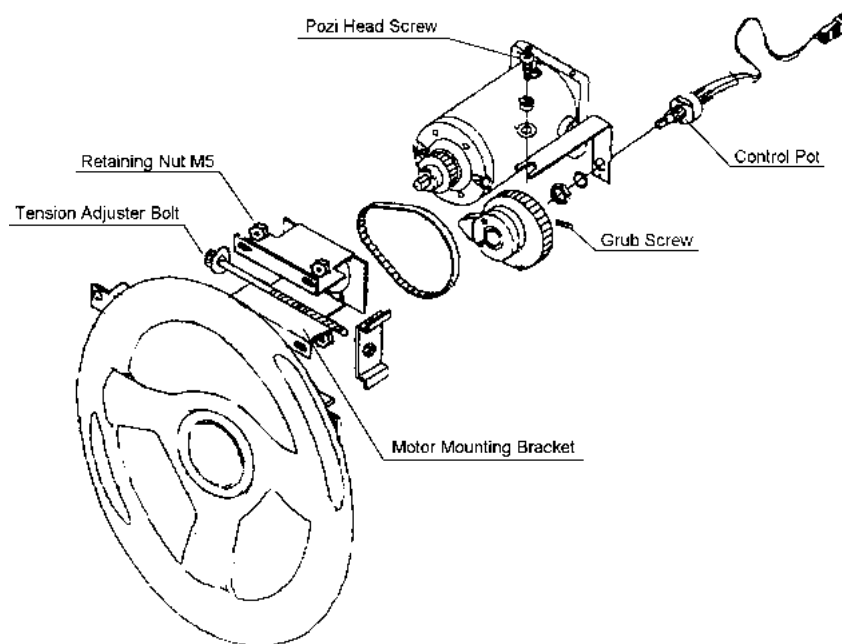
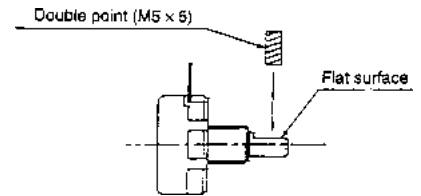

8-4-2 Replacing the Drive Belt or Steering Motor

- 1) Disconnect the motor connector.
- 2) Loosen the four nuts (M5) retaining the motor mounting bracket to the front plate.
- 3) Loosen the tension adjuster bolt (M6x60) and slide the motor mounting bracket towards the main gear to release the drive belt.
- 4) Remove the drive belt.
- 5) Remove the four nuts (M5) and remove the motor and motor mounting plate.

Note:- When replacing the drive belt, the centre part of the belt should be able to bend approx. 2 to 3mm when a force of 500g is applied

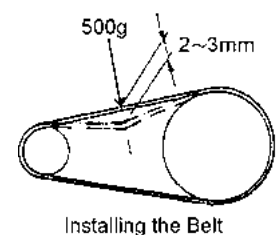

9. PARTS

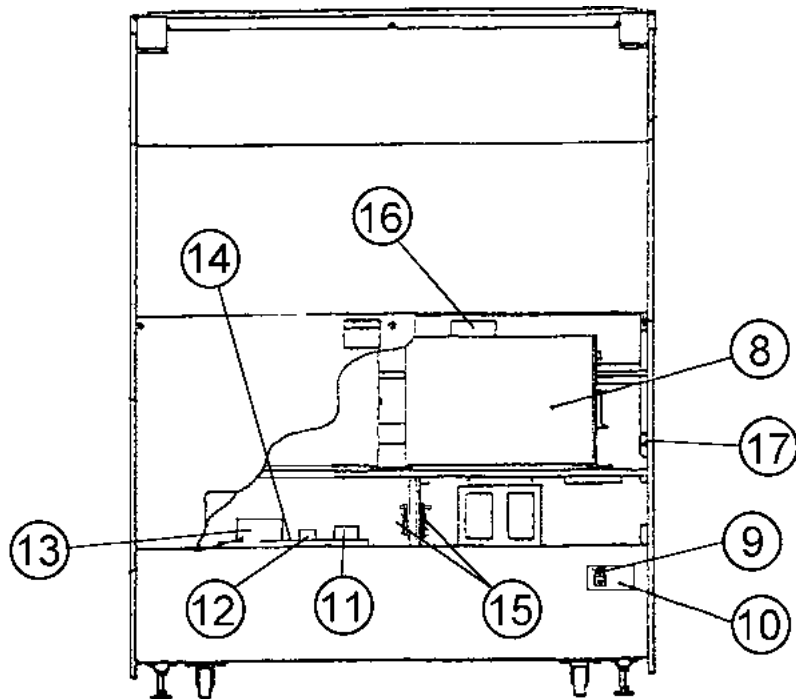
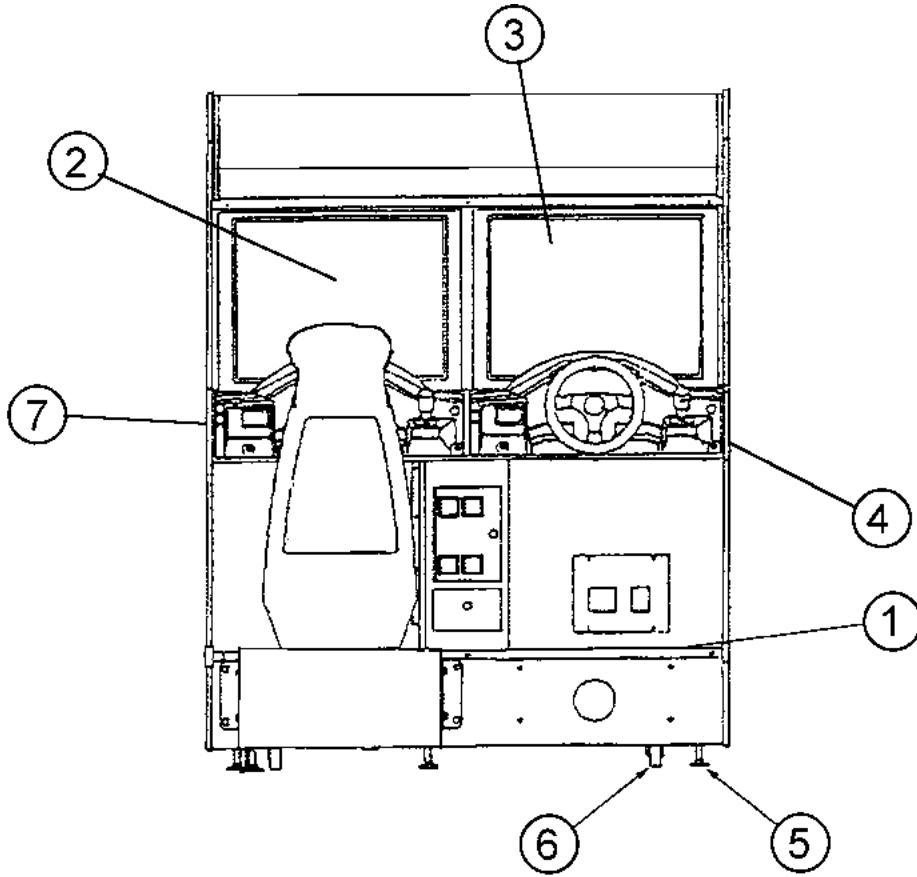

ITEM	DESCRIPTION	PART No
1	EVA Floor Mat	45000184
2	28" Polo Monitor	84000026
3	Front Glass	31000024
4	Side Decal - RHS	45000337
5	M16 Adjustable Foot	88300079
6	Castor - 75mm	59000005
7	Side Decal - LHS	45000336
8	Victory Lap PCB Assembly	XVL - PCB
9	Schaffner Mains Input Assembly	66000016
10	Link PCB Assembly	XAD-LINKPCB
11	Steering PCB Transformer	67700020
12	Lamp Drive PCB	45000670
13	SMPSU - 5V @ 32A / 12V @ 12A	83000001
14	Fuse 1¼" 1A Slo-Blo	63500639
	Fuse 1¼" 1A Q.B.	63500424
	Fuse 1¼" 5A Slo-Blo	63500643
15	Steering Motor PCB	XAD-STEERPCB
16	Fan 240V - 4½"	67000015
17	Interlock Switch	60000006

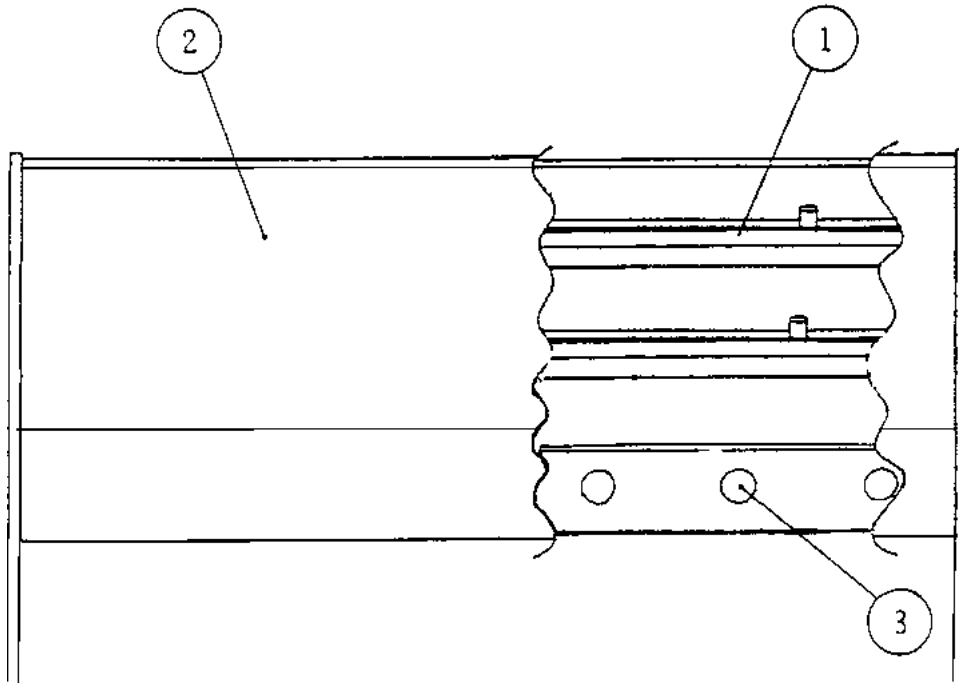

ITEM	DESCRIPTION	PART No
1	FLUORESCENT TUBE - 4ft	64500014
2	HEADER ACRYLIC	24201027
3	E14 240v 25w GOLFBALL LAMP	64000084

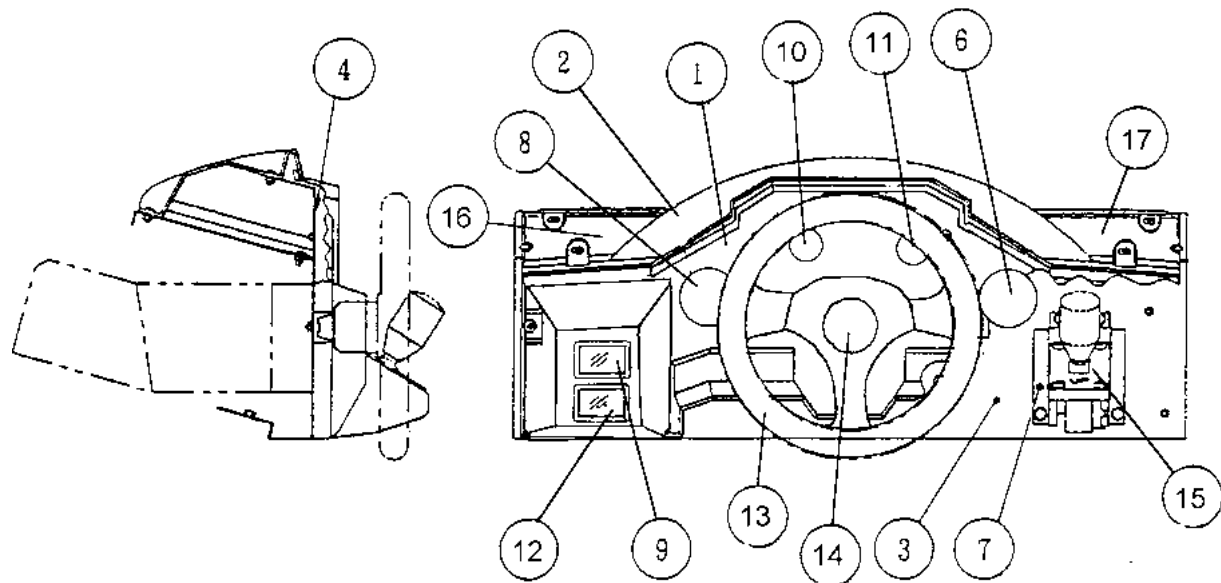

ITEM	DESCRIPTION	PART No
1	Vac-Form Front Decal	40000339
2	Steering Cover Vac-Form - Top	45000919
3	Steering Cover Vac-Form - Front	45000920
4	Front Vac-Form Top Securing Bracket	45000921
6	Speedo Embossed Logo	40000302
7	Shifter Mounting Bracket	45000918
8	RPM Embossed Logo	40000303
9	View Change Button	60200078
10	Pressure Embossed Logo	40000305
11	Oil Embossed Logo	40000304
12	Credit Available When Lit Button	60200215
13	Steering Wheel - 10" Mountney Black Vinyl	88800068
14	Steering Wheel Centre Cap	XAD-463-414E
	Namco Embossed Logo	XAD-295-011
15	Hi/Low Shifter Assembly	X294-700
16	Play Instruction Decal	40000338
17	Champion Points Mode Decal	40000340

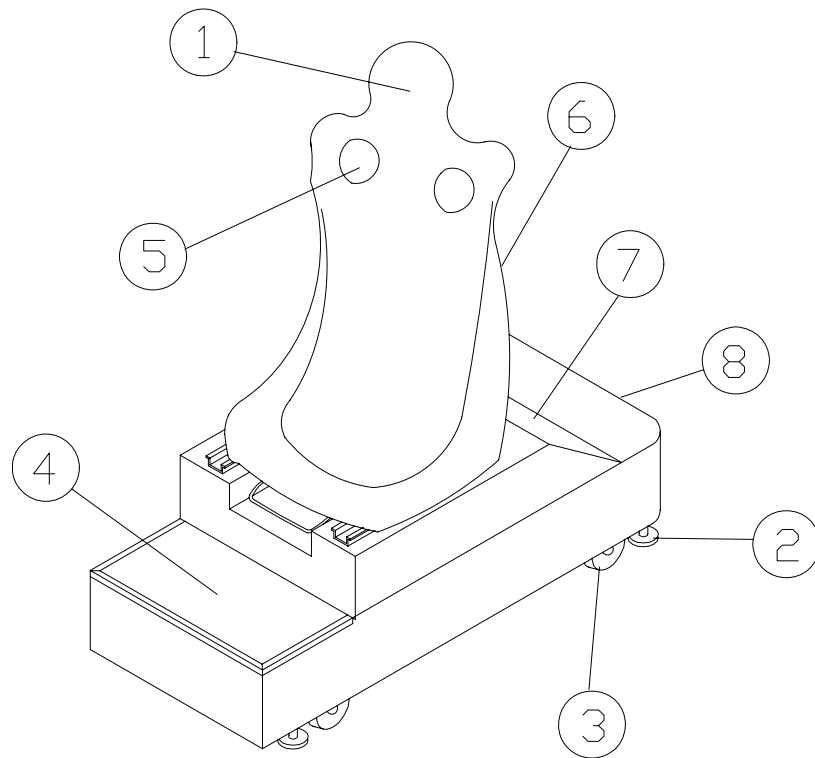

ITEM	DESCRIPTION	PART No
1	Seat - Rotary Moulded - Orange	45000911
2	M16 Adjustable Foot	88300079
3	Swivel Castor - 75mm	59000005
4	EVA Floor Mat	45000176
5	Loudspeaker 4½" 20watt	62000006
	Speaker Plate - LHS - Black	88300603
	Speaker Plate - RHS - Black	88300604
6	Decal - Seat Rear	40000334
7	Seat Base Rear Decal	40000335
8	Decal Namco Base Rear	40000036

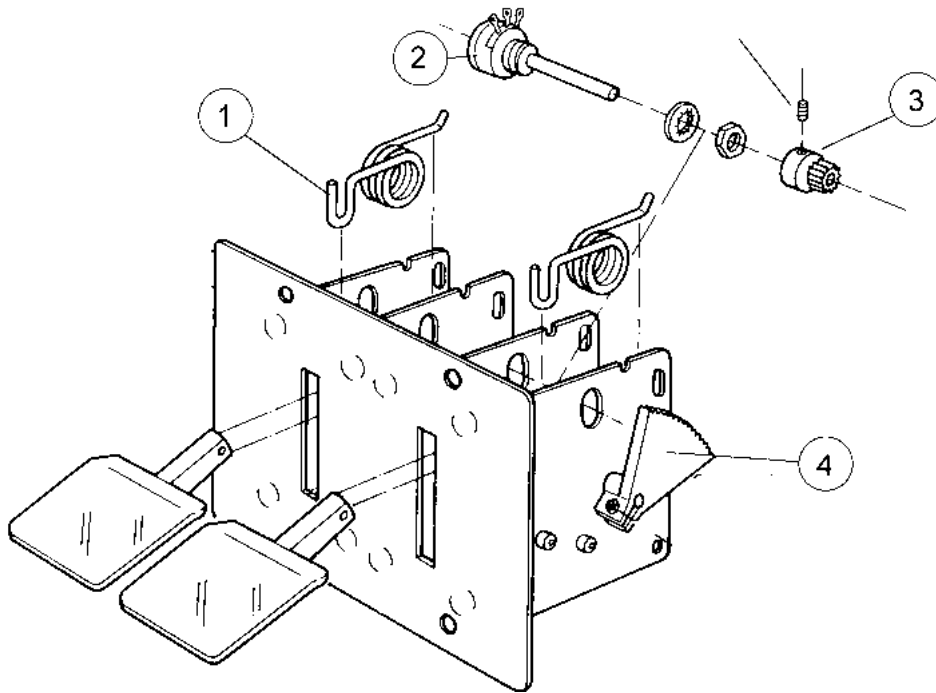

ITEM	DESCRIPTION	PART No
	Pedal Assembly - Complete	88800067
1	Return Spring	88800050
2	Control Pot	88800053
3	Drive Gear	88800052
4	Quadrant Gear	88800051

10 SHEMATIC

